

# **CompactFlash™ Memory Card Product Manual**



CORPORATE HEADQUARTERS

140 Caspian Court  
Sunnyvale, CA 94089  
408-542-0500

FAX: 408-542-0503

URL: <http://www.sandisk.com>

*SanDisk® Corporation general policy does not recommend the use of its products in life support applications where in a failure or malfunction of the product may directly threaten life or injury. Per SanDisk Terms and Conditions of Sale, the user of SanDisk products in life support applications assumes all risk of such use and indemnifies SanDisk against all damages.*

*The information in this manual is subject to change without notice.*

*SanDisk Corporation shall not be liable for technical or editorial errors or omissions contained herein; nor for incidental or consequential damages resulting from the furnishing, performance, or use of this material.*

*All parts of the SanDisk CompactFlash Memory Card documentation are protected by copyright law and all rights are reserved. This documentation may not, in whole or in part, be copied, photocopied, reproduced, translated, or reduced to any electronic medium or machine readable form without prior consent, in writing, from SanDisk Corporation.*

*SanDisk and the SanDisk logo are registered trademarks of SanDisk Corporation. ImageMate, CompactFlash and CF are trademarks of SanDisk Corporation.*

*Product names mentioned herein are for identification purposes only and may be trademarks and/or registered trademarks of their respective companies.*

*© 2000 SanDisk Corporation. All rights reserved.*

*The SanDisk CompactFlash Memory Card is covered or licensed under one or more of the following U.S. Patent Nos. 5,070,032; 5,095,344; 5,168,465; 5,172,338; 5,198,380; 5,200,959; 5,268,318; 5,268,870; 5,272,669; 5,418,752; 5,602,987. Other U.S. and foreign patents awarded and pending.*

*Lit. No. 20-10-00038 Rev. 7 4/2000*

*Printed in U.S.A.*

#### *Revision History*

- Revisions before Rev. 5—initial release and general changes.*
- Revision 5—general editorial changes, CF Type II information added, new higher capacities products added, some lower capacities removed, new card reader/writer vendor added.*
- Revision 6—added new 256 Mbit technology products, general and editorial changes.*
- Revision 7—changes to Translate Sector command (page 73) and Device Control Register Enable bit (page 53).*

## Table of Contents

1.0	Introduction to the CompactFlash Memory Card.....	7
1.1	Scope.....	8
1.2	Product Models.....	8
1.3	System Features.....	9
1.4	PCMCIA Standard.....	9
1.5	CompactFlash Specification.....	9
1.6	Related Documentation.....	9
1.7	Functional Description.....	9
1.7.1	Flash Technology Independence.....	10
1.7.2	Defect and Error Management.....	10
1.7.3	Endurance.....	10
1.7.4	Wear Leveling.....	10
1.7.5	Using the Erase Sector and Write without Erase Commands.....	10
1.7.6	Automatic Sleep Mode.....	11
1.7.7	Dynamic Adjustment of Performance versus Power Consumption.....	11
1.7.8	Power Supply Requirements.....	11
2.0	Product Specifications.....	12
2.1	System Environmental Specifications.....	12
2.2	System Power Requirements.....	12
2.3	System Performance.....	13
2.4	System Reliability and Maintenance.....	13
2.5	Physical Specifications.....	14
2.6	Capacity Specifications.....	18
3.0	Installation.....	19
3.1	Mounting.....	19
4.0	CompactFlash Memory Card Interface Description.....	20
4.1	Physical Description.....	20
4.1.1	Pin Assignments and Pin Type.....	20
4.2	Electrical Description.....	20
4.3	Electrical Specification.....	27
4.3.1	Input Leakage Current.....	27
4.3.2	Input Characteristics.....	27
4.3.3	Output Drive Type.....	28
4.3.4	Output Drive Characteristics.....	28
4.3.5	Interface/Bus Timing.....	29
4.3.6	Attribute Memory Read Timing Specification.....	29
4.3.7	Attribute Memory Write Timing Specification.....	30
4.3.8	Common Memory Read Timing Specification.....	31
4.3.9	Common Memory Write Timing Specification.....	32
4.3.10	I/O Input (Read) Timing Specification.....	33
4.3.11	I/O Output (Write) Timing Specification.....	34
4.3.12	True IDE Mode I/O Input (Read) Timing Specification.....	35
4.3.13	True IDE Mode I/O Output (Write) Timing Specification.....	36
4.4	Card Configuration.....	37

## Table of Contents (continued)

4.4.1	Attribute Memory Function.....	38
4.4.2	Configuration Option Register (Address 200h in Attribute Memory).....	39
4.4.3	Card Configuration and Status Register (Address 202h in Attribute Memory).....	39
4.4.4	Pin Replacement Register (Address 204h in Attribute Memory).....	40
4.4.5	Socket and Copy Register (Address 206h in Attribute Memory).....	41
4.5	I/O Transfer Function .....	42
4.5.1	I/O Function.....	42
4.6	Common Memory Transfer Function .....	43
4.6.1	Common Memory Function.....	43
4.7	True IDE Mode I/O Transfer Function .....	44
4.7.1	True IDE Mode I/O Function.....	44
5.0	ATA Drive Register Set Definition and Protocol .....	45
5.1	I/O Primary and Secondary Address Configurations.....	46
5.2	Contiguous I/O Mapped Addressing.....	47
5.3	Memory Mapped Addressing .....	48
5.4	True IDE Mode Addressing.....	49
5.5	ATA Registers.....	50
5.5.1	Data Register (Address - 1F0[170]; Offset 0,8,9).....	50
5.5.2	Error Register (Address - 1F1[171]; Offset 1, 0Dh Read Only).....	51
5.5.3	Feature Register (Address - 1F1[171]; Offset 1, 0Dh Write Only).....	51
5.5.4	Sector Count Register (Address - 1F2[172]; Offset 2) .....	51
5.5.5	Sector Number (LBA 7-0) Register (Address - 1F3[173]; Offset 3).....	51
5.5.6	Cylinder Low (LBA 15-8) Register (Address - 1F4[174]; Offset 4) .....	51
5.5.7	Cylinder High (LBA 23-16) Register (Address - 1F5[175]; Offset 5).....	51
5.5.8	Drive/Head (LBA 27-24) Register (Address 1F6[176]; Offset 6).....	52
5.5.9	Status & Alternate Status Registers (Address 1F7[177]&3F6[376]; Offsets 7 & Eh) 53	
5.5.10	Device Control Register (Address - 3F6[376]; Offset Eh).....	53
5.5.11	Card (Drive) Address Register (Address 3F7[377]; Offset Fh) .....	54
6.0	ATA Command Description .....	55
6.1	ATA Command Set.....	55
6.1.1	Check Power Mode - 98H, E5H.....	57
6.1.2	Execute Drive Diagnostic - 90H.....	57
6.1.3	Erase Sector(s) - C0H.....	58
6.1.4	Format Track - 50H .....	59
6.1.5	Identify Drive - ECH .....	59
6.1.5.1	General Configuration.....	61
6.1.5.2	Default Number of Cylinders.....	61
6.1.5.3	Default Number of Heads.....	61
6.1.5.4	Number of Unformatted Bytes per Track .....	61
6.1.5.5	Number of Unformatted Bytes per Sector.....	61
6.1.5.6	Default Number of Sectors per Track.....	61
6.1.5.7	Number of Sectors per Card.....	61
6.1.5.8	Memory Card Serial Number.....	61
6.1.5.9	Buffer Type.....	61
6.1.5.10	Buffer Size.....	61
6.1.5.11	ECC Count.....	61

**Table of Contents (continued)**

6.1.5.12	Firmware Revision.....	61
6.1.5.13	Model Number .....	61
6.1.5.14	Read/Write Multiple Sector Count.....	62
6.1.5.15	Double Word Support.....	62
6.1.5.16	Capabilities.....	62
6.1.5.17	PIO Data Transfer Cycle Timing Mode.....	62
6.1.5.18	DMA Data Transfer Cycle Timing Mode.....	62
6.1.5.19	Translation Parameters Valid.....	62
6.1.5.20	Current Number of Cylinders, Heads, Sectors/Track.....	62
6.1.5.21	Current Capacity .....	62
6.1.5.22	Multiple Sector Setting .....	62
6.1.5.23	Total Sectors Addressable in LBA Mode.....	62
6.1.6	Idle - 97H, E3H.....	63
6.1.7	Idle Immediate - 95H, E1H.....	63
6.1.8	Initialize Drive Parameters - 91H.....	64
6.1.9	Read Buffer - E4H.....	64
6.1.10	Read Multiple - C4H.....	65
6.1.11	Read Long Sector - 22H, 23H.....	66
6.1.12	Read Sector(s) - 20H, 21H.....	66
6.1.13	Read Verify Sector(s) - 40H, 41H.....	67
6.1.14	Recalibrate - 1XH.....	67
6.1.15	Request Sense - 03H.....	68
6.1.16	Seek - 7XH.....	69
6.1.17	Set Features - EFH .....	69
6.1.18	Set Multiple Mode - C6H.....	71
6.1.19	Set Sleep Mode- 99H, E6H.....	71
6.1.20	Standby - 96H, E2H.....	72
6.1.21	Standby Immediate - 94H, E0H .....	72
6.1.22	Translate Sector - 87H.....	73
6.1.23	Wear Level - F5H .....	74
6.1.24	Write Buffer - E8H.....	74
6.1.25	Write Long Sector - 32H, 33H.....	75
6.1.26	Write Multiple Command - C5H.....	75
6.1.27	Write Multiple without Erase - CDH .....	76
6.1.28	Write Sector(s) - 30H, 31H .....	77
6.1.29	Write Sector(s) without Erase - 38H .....	77
6.1.30	Write Verify Sector(s) - 3CH.....	78
6.2	Error Posting.....	79
7.0	CIS Description.....	81
	Ordering Information and Technical Support .....	97
	Ordering Information .....	99
	CompactFlash Memory Card.....	99
	SanDisk ImageMate™ CompactFlash Drive.....	99
	CompactFlash Memory Card Evaluation Kit .....	99
	System Software, Card Reader/Writers and Connectors	
	Compatible with the SanDisk CompactFlash Memory Cards .....	100
	Technical Support Services.....	104

# **CompactFlash Memory Card Product Manual**

## ***Table of Contents (continued)***

Direct SanDisk Technical Support.....	104
SanDisk Worldwide Web Site.....	104
SanDisk Sales Offices.....	105
Appendix CompactFlash Connector Specifications .....	109
Limited Warranty.....	119

# **1.0 Introduction to the CompactFlash Memory Card**

The SanDisk CompactFlash™ Memory Card (CF™) products provide high capacity solid state flash memory that electrically complies with the Personal Computer Memory Card International Association ATA (PC Card ATA) standard. (In Japan, the applicable standards group is JEIDA.) The CompactFlash Memory Card Series also supports a True IDE Mode that is electrically compatible with an IDE disk drive. CompactFlash Memory Cards provide up to 300 million bytes (Megabytes, MBytes or MB) of formatted storage capacity in the CF Type II form factor and 192 megabytes in the original CF form factor. The original CF form factor card can be used in any system that has a CF slot, and with a Type II PCMCIA adapter can be used in any system that has a PCMCIA Type II or Type III socket. The newer CF Type II card fits into a CF Type II slot.

SanDisk has expanded the available capacity of the CompactFlash Storage Card by offering a new CF Type II form factor. Just slightly thicker than the original CF form factor, the CF Type II form factor is 5 mm thick instead of 3.3 mm thick.

With previous generations of SanDisk Binary flash technologies, there was a limitation of 300,000 or less endurance cycles. SanDisk has developed the 256 Mbit Flash technology to eliminate this limitation in response to customer requests. As a result, the life expectancy of SanDisk 256 Mbit Flash Technology products and future generation multilevel products will result in a substantial increase in life. For typical digital camera, MP3, PDA and other consumer applications, this translates into a benefit of an unlimited life expectancy. Industrial applications

employing the 256 Mbit Flash Technology will also see a substantial life improvement.

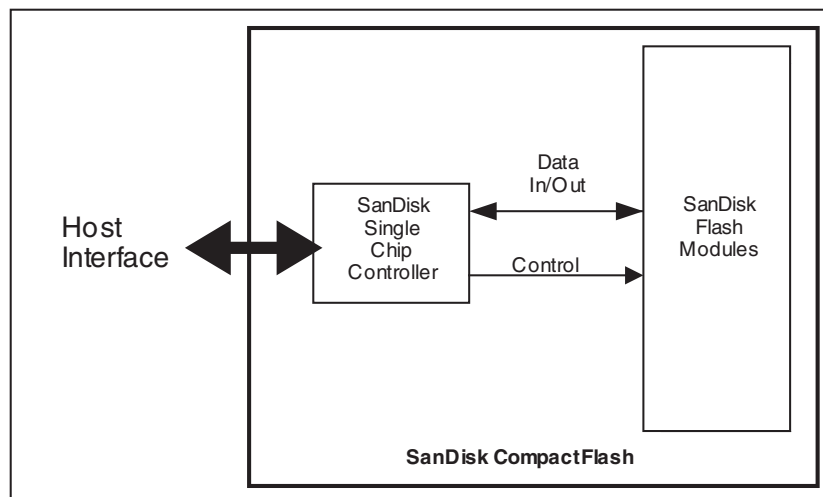
The CompactFlash Memory Cards use SanDisk Flash memory which was designed by SanDisk specifically for use in mass storage applications. In addition to the mass storage specific Flash memory chips, the CompactFlash Memory Cards include an on-card intelligent controller that provides a high level interface to the host computer. This interface allows a host computer to issue commands to the memory card to read or write blocks of memory. A block of memory consists of 512 bytes of data and is protected by a powerful Error Correcting Code (ECC).

The CompactFlash Memory Card on-card intelligent controller manages interface protocols, data storage and retrieval as well as ECC, defect handling and diagnostics, power management and clock control. Once the CompactFlash Memory Card has been configured by the host, it appears to the host as a standard ATA (IDE) disk drive. Additional ATA commands have been provided to enhance system performance.

The host system can support as many cards as there are CompactFlash, CompactFlash Type II and PCMCIA Type II or III card slots. The original form factor CompactFlash Memory Cards require a PCMCIA Type II Adapter to be used in a PCMCIA Type II or Type III socket.

SanDisk also offers an industrial version of the CompactFlash Memory Card Series, which has a broader operating and non-operating temperature range than the standard product. Please see Section 2 for detailed specifications.

# CompactFlash Memory Card Product Manual



**Figure 1-1 CompactFlash Memory Card Block Diagram**

## 1.1 Scope

This document describes the key features and specifications of CompactFlash Memory Cards, as well as the information required to interface this product to a host system.

## 1.2 Product Models

The CompactFlash Memory Card Series is available in a variety of capacities as shown in the following table. All models are shipped formatted with a DOS file structure.

Standard Model	Industrial Model	Capacity (formatted)
SDCFB-8	SDCFBI-8	8.0 MB
SDCFB-16	SDCFBI-16	16.0 MB
SDCFB-32	SDCFBI-32	32.1 MB
SDCFB-48	SDCFBI-48	48.1 MB
SDCFB-64	SDCFBI-64	64.2 MB
SDCFB-80	SDCFBI-80	80.2 MB
SDCFB-96	SDCFBI-96	96.2 MB
SDCFB-128	SDCFBI-128	128.4 MB
SDCFB-160	SDCFBI-160	160.4 MB
SDCFB-192	SDCFBI-192	192.4 MB
SDCF2B-256 (CF Type II)	SDCF2BI-256	256.9 MB
SDCF2B-300 (CF Type II)	SDCF2BI-300	300.3 MB



---

## 1.3 System Features

- The industry's smallest form factor
- Up to 300 MBytes of mass storage data (in CF Type II form factor)
- PC Card ATA protocol compatible
- True IDE Mode compatible
- Very low CMOS power
- Very high performance
- Very rugged
- Low weight
- Noiseless
- Low Profile
- +5 Volts or +3.3 Volts operation
- Automatic error correction and retry capabilities
- Supports power down commands and sleep modes
- Non-volatile storage (no battery required)
- MTBF >1,000,000 hours
- Minimum 10,000 insertions
- Standard (SDCFB and SDCF2B Series) and Industrial versions (SDCF2BI and SDCFBI Series)

---

## 1.4 PCMCIA Standard

CompactFlash Memory Cards are fully electrically compatible with the PCMCIA specifications listed below. These specifications may be obtained from:

PCMCIA  
2635 North First St., Ste. 209  
San Jose, CA 95131  
USA  
Phone: 408-433-2273  
FAX: 408-433-9558

- 1) PCMCIA PC Card Standard, January 1995
- 2) PCMCIA PC Card ATA Specification, January 1995

---

## 1.5 CompactFlash Specification

CompactFlash Memory Cards are fully compatible with the CompactFlash Specification published by the CompactFlash Association. Contact the CompactFlash Association for more information.

CompactFlash Association  
P.O. Box 51537  
Palo Alto, CA 94303  
USA  
Phone: 415-843-1220  
FAX: 415-493-1871  
www.compactflash.org

---

## 1.6 Related Documentation

- 1) American National Standard X3.221  
AT Attachment for Interface for Disk Drives Document

This document can be ordered from Global Engineering Documents by calling 1-800-854-7179.

---

## 1.7 Functional Description

CompactFlash Memory Cards contain a high level, intelligent subsystem as shown in the block diagram, Figure 1-1. This intelligent (microprocessor) subsystem provides many capabilities not found in other types of memory cards. These capabilities include:

1. Standard ATA register and command set (same as found on most magnetic disk drives).
2. Host independence from details of erasing and programming flash memory.
3. Sophisticated system for managing defects (analogous to systems found in magnetic disk drives).
4. Sophisticated system for error recovery including a powerful error correction code (ECC).
5. Power management for low power operation.

# **CompactFlash Memory Card Product Manual**

---

## **1.7.1 Flash Technology Independence**

The 512 byte sector size of CompactFlash Memory Card is the same as that in an IDE magnetic disk drive. To write or read a sector (or multiple sectors), the host computer software simply issues a Read or Write command to the CompactFlash Memory Card. This command contains the address and the number of sectors to write/read. The host software then waits for the command to complete. The host software does not get involved in the details of how the flash memory is erased, programmed or read. This is extremely important as flash devices are expected to get more and more complex in the future. Since the CompactFlash Memory Card Series uses an intelligent on-board controller, the host system software will not require changing as new flash memory evolves. In other words, systems that support the CompactFlash Memory Card today will be able to access future SanDisk cards built with new flash technology without having to update or change host software.

---

## **1.7.2 Defect and Error Management**

CompactFlash Memory Cards contain a sophisticated defect and error management system. This system is analogous to the systems found in magnetic disk drives and in many cases offers enhancements. For instance, disk drives do not typically perform a read after write to confirm the data is written correctly because of the performance penalty that would be incurred. CompactFlash Memory Cards do a read after write under margin conditions to verify that the data is written correctly. If necessary, CompactFlash Memory Cards will replace the entire sector with a spare sector. This is completely transparent to the host and does not consume any user data space.

The CompactFlash Memory Card soft error rate specification is much better than the magnetic disk drive specification. In the extremely rare case a read error does occur, CompactFlash Memory Cards have innovative algorithms to recover the data. This is similar to using retries on a disk drive but is much more sophisticated. The last line of defense is to employ a powerful ECC to correct the data. If ECC is used to recover data,

defective bits are replaced with spare bits to ensure they do not cause any future problems.

These defect and error management systems coupled with the solid state construction give CompactFlash Memory Cards unparalleled reliability.

---

## **1.7.3 Endurance**

With the introduction of the 256 Mbit Flash Technology, CompactFlash Cards have almost unlimited write endurance (reading a logical sector is unlimited). This results in an added benefit to the user where the anticipated life of the CompactFlash products is now substantially increased over the life of previous SanDisk Binary Flash technology products.

---

## **1.7.4 Wear Leveling**

CompactFlash Memory Card Series products do not require or perform a Wear Level operation. The command is supported as a NOP operation to maintain backward compatibility with existing software utilities.

---

## **1.7.5 Using the Erase Sector and Write without Erase Commands**

As a result of the CompactFlash Card's almost unlimited endurance, the Erase Sector and Write Without Erase Commands are no longer supported. There will be no net gain in the use of these commands. Since the write performance of SanDisk products typically improves with the introduction of next generation flash technologies, this feature is no longer required. Any platforms employing these commands in previous SanDisk products will not be affected as a result of the elimination of this function. The Erase Sector Command will still erase the sectors but the Write Without Erase Command will perform a normal Write Command resulting in no net gain in write performance.

---

## 1.7.6 Automatic Sleep Mode

A unique feature of the SanDisk CompactFlash Memory Card (and other SanDisk products) is automatic entrance and exit from sleep mode. Upon completion of a command, the CompactFlash Card will enter the sleep mode to conserve power if no further commands are received within 5 msec. The host does not have to take any action for this to occur. In most systems, the CompactFlash Memory Card is in sleep mode except when the host is accessing it, thus conserving power. Note that the delay from command completion to entering sleep mode can be adjusted.

When the host is ready to access the CompactFlash Memory Card and it is in sleep mode, any command issued to the CompactFlash Card will cause it to exit sleep and respond. The host does not have to follow the ATA protocol of issuing a reset first. It may do this if desired, but it is not needed. By not issuing the reset, performance is improved through the reduction of overhead but this must be done only for the SanDisk products as other ATA products may not support this feature.

---

## 1.7.7 Dynamic Adjustment of Performance versus Power Consumption

This feature is no longer supported. This command will be treated as a NOP (No Operation) to guarantee backward compatibility.

---

## 1.7.8 Power Supply Requirements

This is a dual voltage product which means it will operate at a voltage range of 3.30 volts  $\pm$  5% or 5.00 volts  $\pm$  10% ( $\pm$  5% for industrial versions). Per the PCMCIA specification section 2.1.1, the host system must apply 0 volts in order to change a voltage range. This same procedure of providing 0 volts to the card is required if the host system applies an input voltage outside the desired voltage by more than 20%. This means less than 4.0 volts for the 5.00 volt range and less than 2.70 volts for the 3.30 volt range.

## 2.0 Product Specifications

For all the following specifications, values are defined at ambient temperature and nominal supply voltage unless otherwise stated.

### 2.1 System Environmental Specifications

		Standard Product (SDCFB and SDCF2B)	Industrial Product (SDCFBI and SDCF2BI)
Temperature	Operating: Non-Operating:	0° C to 60° C -25° C to 85° C	-40° C to 85° C -50° C to 100° C
Humidity	Operating: Non-Operating:	8% to 95%, non-condensing 8% to 95%, non-condensing	8% to 95%, non-condensing 8% to 95%, non-condensing
Acoustic Noise:		0 dB	0 dB
Vibration	Operating: Non-Operating:	15 G peak to peak max. 15 G peak to peak max.	15 G peak to peak max. 15 G peak to peak max.
Shock	Operating: Non-Operating:	2,000 G max. 2,000 G max.	2,000 G max. 2,000 G max.
Altitude (relative to sea level)	Operating: Non-Operating:	80,000 feet max. 80,000 feet max.	80,000 feet max. 80,000 feet max.

### 2.2 System Power Requirements

		Standard Product (SDCFB and SDCF2B)		Industrial Product (SDCFBI and SDCF2BI)	
DC Input Voltage (VCC) 100 mV max. ripple (p-p)		3.3V ±5%	5V ± 10%	3.3V ±5%	5V ±5%
+5 V Currents (maximum Average value) See Notes 1 to 3.	Sleep: Reading: Writing: Read/Write Peak	200 µA (Slow - Fast) 32 mA - 45 mA 32 mA - 60 mA 150 mA/50µs	500 µA (Slow - Fast) 46 mA - 75 mA 46 mA - 90 mA 150 mA/50µs	200 µA (Slow - Fast) 32 mA - 45 mA 32 mA - 60 mA 150 mA/50µs	500 µA (Slow - Fast) 46 mA - 75 mA 46 mA - 90 mA 150 mA/50µs

Note 1. All values quoted are typical at ambient temperature and nominal supply voltage unless otherwise stated.

Note 2. Sleep mode currently is specified under the condition that all card inputs are static CMOS levels and in a "Not Busy" operating state.

Note 3. The currents specified show the bounds of programmability of the product.

## 2.3 System Performance

All performance timings assume the CompactFlash Memory Card Series controller is in the default (i.e., fastest) mode.

Start Up Times	Sleep to write: Sleep to read: Reset to ready:	2.5 msec maximum 2.0 msec maximum 50 msec typical 400 msec maximum
Active to Sleep Delay		Programmable
Data Transfer Rate To/From Flash		20.0 MBytes/sec burst
Data Transfer Rate To/From Host		16.0 MBytes/sec burst
Controller Overhead	Command to DRQ	1.25 msec maximum

Note: The Sleep to Write and Sleep to Read times are the times it takes the CompactFlash Memory Card to exit sleep mode when any command is issued by the host to when the card is reading or writing. CompactFlash Memory Cards do not require a reset to exit sleep mode. See section 1.8.6.

## 2.4 System Reliability and Maintenance

MTBF (@ 25°C)	>1,000,000 hours
Preventive Maintenance	None
Data Reliability	<1 non-recoverable error in $10^{14}$ bits read
Endurance SDCFB-XX	$\geq 300,000$ erase / program cycles per logical sector guaranteed
Endurance SDCFBI-XX Industrial Product	$\geq 100,000$ erase / program cycles per logical sector guaranteed

# CompactFlash Memory Card Product Manual

## 2.5 Physical Specifications

Refer to the following table and to Figures 2-1 and 2-2 for CompactFlash Memory Card physical specifications and dimensions.

	CompactFlash	CompactFlash Type II
Weight:	11.4 g (.40 oz) typical 14.2 g (.50 oz) maximum	13.5 g (.47 oz) typical
Length:	36.40 ± 0.15 mm (1.433 ± .006 in.)	36.4 ± 0.15 mm (1.433 ± .006 in.)
Width:	42.80 ± 0.10 mm (1.685 ± .004 in.)	42.80 ± 0.10 mm (1.685 ± .004 in.)
Thickness:	3.3 mm ± 0.10 mm (.130 ± .004 in.) (Excluding Lip)	5.0 mm maximum (.1968 in. maximum)

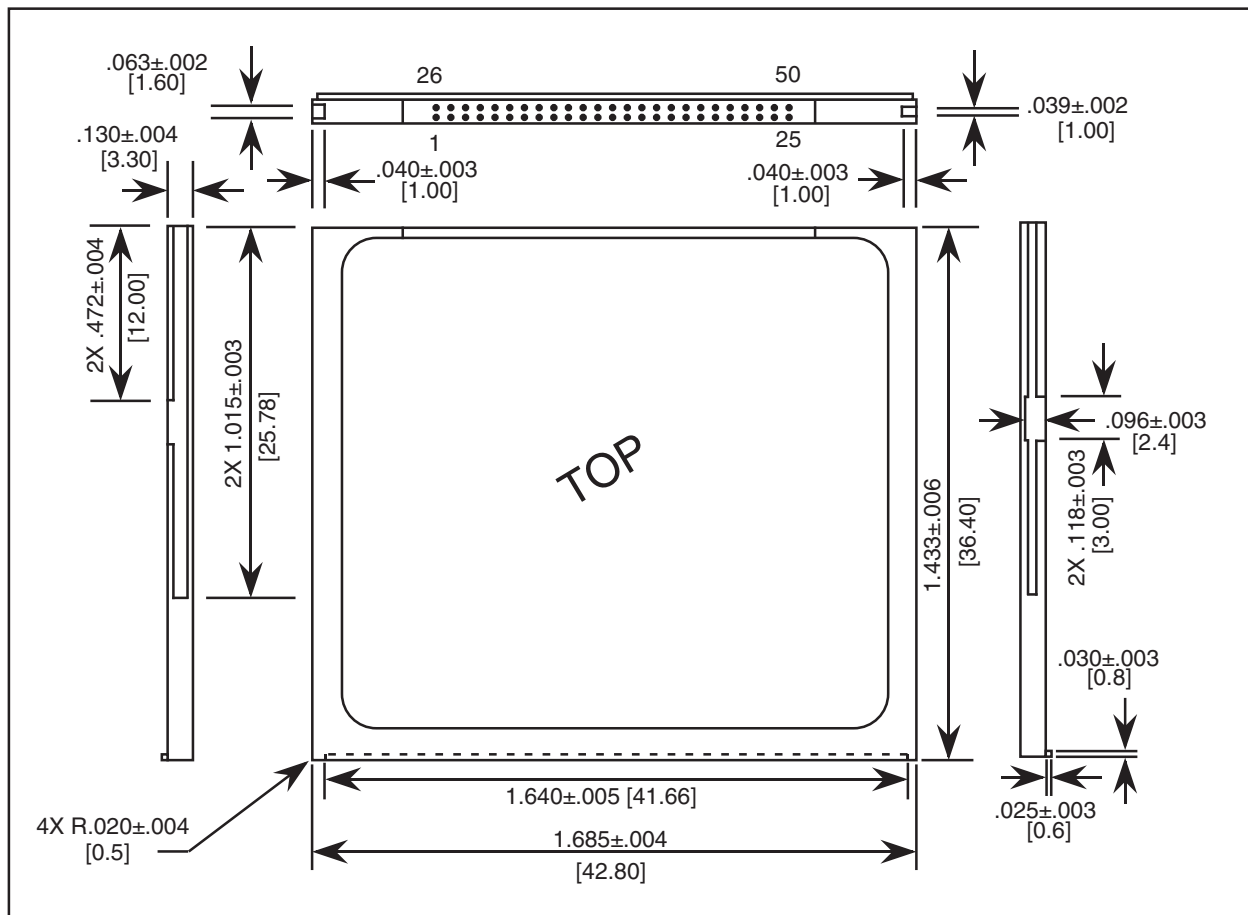


Figure 2-1 CompactFlash Memory Card Dimensions

# CompactFlash Memory Card Product Manual

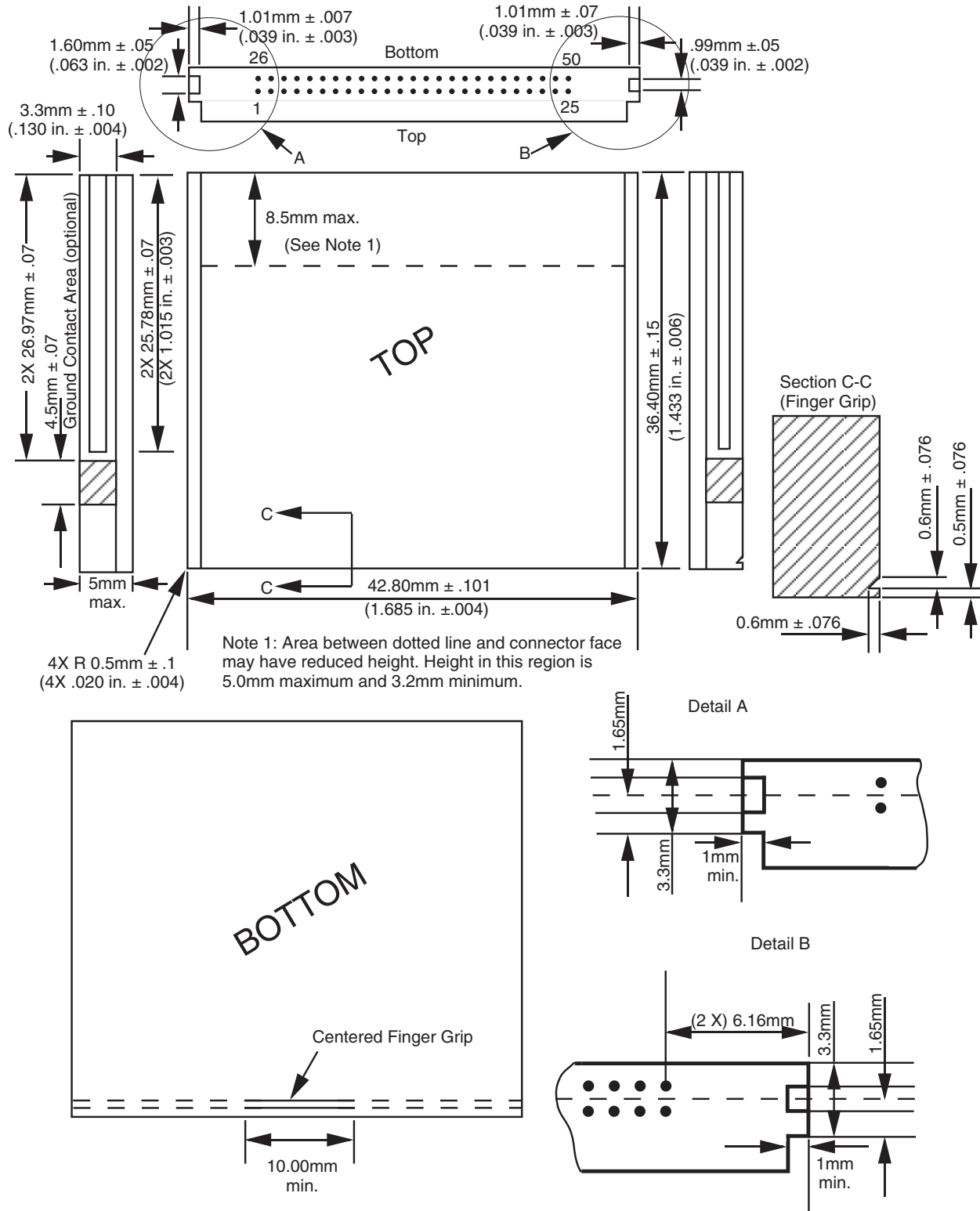
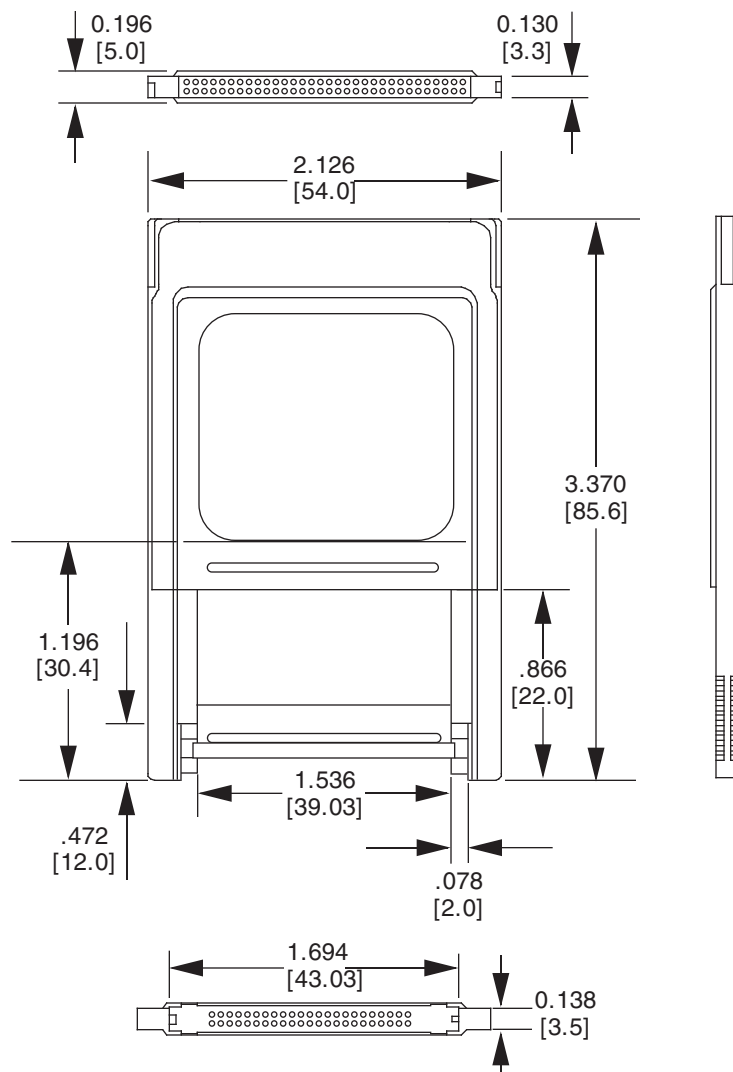


Figure 2-2 CompactFlash Type II Memory Card Dimensions

## CompactFlash Memory Card Product Manual

Refer to the following table and to Figure 2-3 for CompactFlash Memory Card PC Card Adapter physical specifications and dimensions.

	CF Adapter	CF Type II Adapter
Weight:	33 g (1.16 oz) typical	26.6 g (.93 oz) maximum
Length:	85.6 ± 0.20 mm (3.370 ± .008 in)	85.6 ± 0.20 mm (3.370 ± .008 in)
Width:	54.0 ± 0.10 mm (2.126 ± .004 in)	54.0 ± 0.10 mm (2.126 ± .004 in)
Thickness:	5.0 mm Max (0.1968 in)	5.0 mm Max (0.1968 in)



**Figure 2-3 CompactFlash Memory Card Adapter Dimensions**



# CompactFlash Memory Card Product Manual

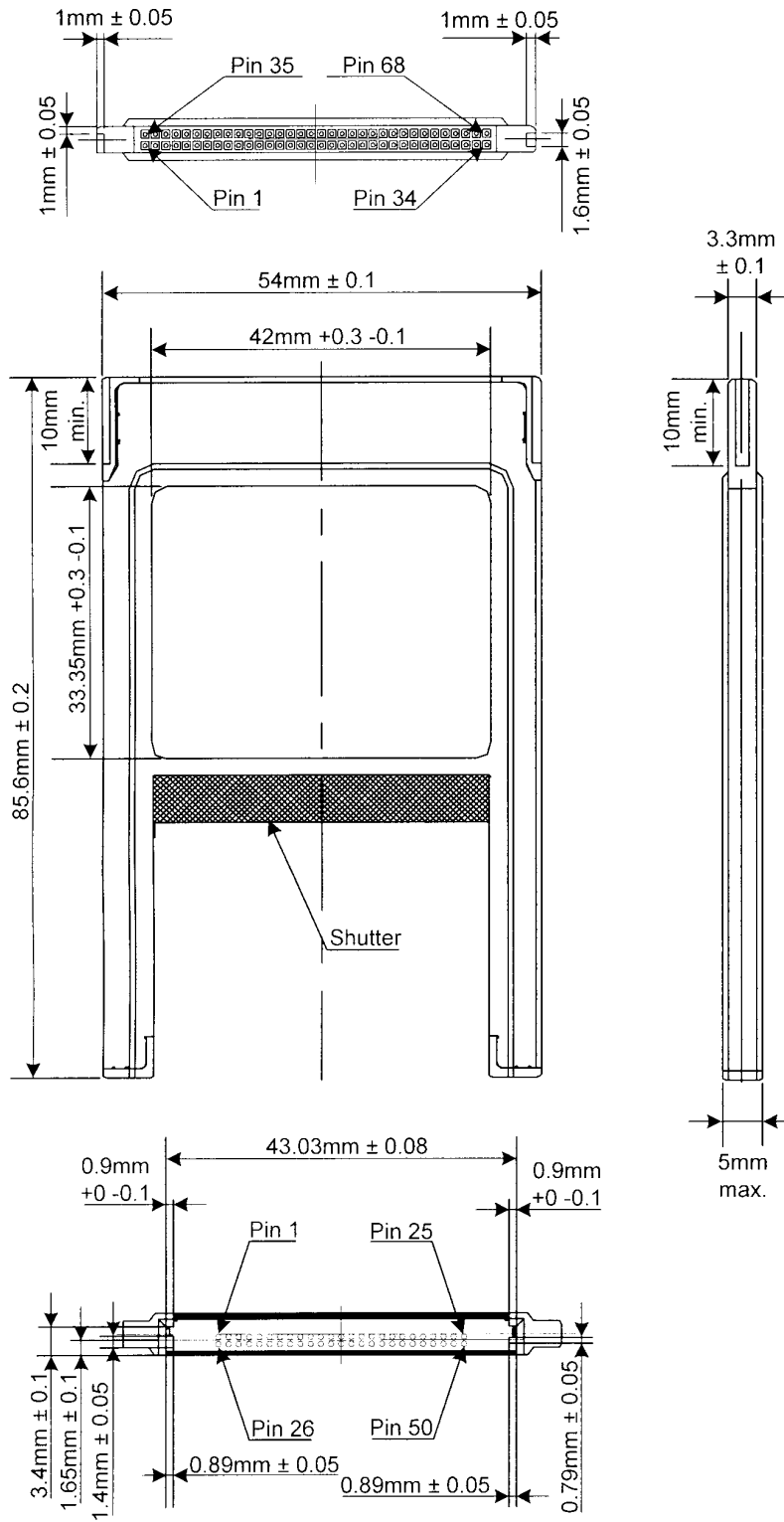


Figure 2-4 CompactFlash Type II Memory Card Adapter Dimensions

## **CompactFlash Memory Card Product Manual**

### **2.6 Capacity Specifications**

The table below shows the specific capacity for the various models and the default number of heads, sectors/track and cylinders.

<b>Model Number</b>	<b>Capacity (formatted)</b>	<b>Sectors/Card (Max LBA+1)</b>	<b>No. of Heads</b>	<b>No. of Sectors/Track</b>	<b>No. of Cylinders</b>
SDCFB-8	8,028,160 bytes	15,680	2	32	245
SDCFB-16	16,056,320 bytes	31,360	2	32	490
SDCFB-32	32,112,640 bytes	62,720	4	32	490
SDCFB-48	48,103,424 bytes	93,952	4	32	734
SDCFB-64	64,225,280 bytes	125,440	8	32	490
SDCFB-80	80,216,064 bytes	156,672	8	32	612
SDCFB-96	96,206,848 bytes	187,904	8	32	734
SDCFB-128	128,450,560 bytes	250,880	8	32	980
SDCFB-160	160,432,128 bytes	313,344	12	32	816
SDCFB-192	192,413,696 bytes	375,808	16	32	734
SDCF2B-256	256,901,120 bytes	501,760	16	32	980
SDCF2B-300	300,367,872 bytes	586,656	12	63	776

## **3.0 Installation**

### **3.1 Mounting**

The CompactFlash Memory Card may be installed in any platform with a 50 position Surface Mount Interface Header (3M P/N N7E50-7516VY-20) and Ejector (3M P/N D7E50-7316-02), or equivalent, properly installed. Refer to the appendix at the end of this manual for additional technical information.

In addition, the CompactFlash Memory Card may be used in any standard PCMCIA Type II (5 mm) or Type III (10.5 mm) socket as supplied by an OEM using a Type II PCMCIA adapter.

The CompactFlash Type II Memory Card fits into a CF Type II slot.

## **4.0 CompactFlash Memory Card Interface Description**

### **4.1 Physical Description**

The host is connected to the CompactFlash Memory Card using a standard 50 pin connector consisting of two rows of 25 female contacts each on 50 mil (1.27 mm) centers.

#### **4.1.1 Pin Assignments and Pin Type**

The signal/pin assignments are listed in Table 4-1. Low active signals have a “-” prefix. Pin types are Input, Output or Input/Output. Table 4-2 defines the DC characteristics for all input and output type structures.

### **4.2 Electrical Description**

The CompactFlash Memory Card Series is optimized for operation with hosts which support the PCMCIA I/O interface standard conforming to the PC Card ATA specification. However, the CompactFlash Card may also be configured to operate in systems that support only the memory interface standard. The configuration of the CompactFlash Card will be controlled using the standard PCMCIA configuration registers starting at address 200h in the Attribute Memory space of the CompactFlash Memory Card.

Table 4-2 describes the I/O signals. Signals whose source is the host are designated as inputs while signals that the CompactFlash Memory Card sources are outputs. The CompactFlash Card logic levels conform to those specified in the PCMCIA Release 2.1 specification. Refer to section 4.3 for definitions of Input and Output type.

## CompactFlash Memory Card Product Manual

**Table 4-1 Pin Assignments and Pin Type**

PC Card Memory Mode				PC Card I/O Mode				True IDE Mode			
Pin Num	Signal Name	Pin Type	In, Out <sup>4</sup> Type	Pin Num	Signal Name	Pin Type	In, Out <sup>4</sup> Type	Pin Num	Signal Name	Pin Type	In, Out <sup>4</sup> Type
1	GND		Ground	1	GND		Ground	1	GND		Ground
2	D03	I/O	I1Z,OZ3	2	D03	I/O	I1Z,OZ3	2	D03	I/O	I1Z,OZ3
3	D04	I/O	I1Z,OZ3	3	D04	I/O	I1Z,OZ3	3	D04	I/O	I1Z,OZ3
4	D05	I/O	I1Z,OZ3	4	D05	I/O	I1Z,OZ3	4	D05	I/O	I1Z,OZ3
5	D06	I/O	I1Z,OZ3	5	D06	I/O	I1Z,OZ3	5	D06	I/O	I1Z,OZ3
6	D07	I/O	I1Z,OZ3	6	D07	I/O	I1Z,OZ3	6	D07	I/O	I1Z,OZ3
7	-CE1	I	I3U	7	-CE1	I	I3U	7	-CS0	I	I3Z
8	A10	I	I1Z	8	A10	I	I1Z	8	A10 <sup>2</sup>	I	I1Z
9	-OE	I	I3U	9	-OE	I	I3U	9	-ATA SEL	I	I3U
10	A09	I	I1Z	10	A09	I	I1Z	10	A09 <sup>2</sup>	I	I1Z
11	A08	I	I1Z	11	A08	I	I1Z	11	A08 <sup>2</sup>	I	I1Z
12	A07	I	I1Z	12	A07	I	I1Z	12	A07 <sup>2</sup>	I	I1Z
13	VCC		Power	13	VCC		Power	13	VCC		Power
14	A06	I	I1Z	14	A06	I	I1Z	14	A06 <sup>2</sup>	I	I1Z
15	A05	I	I1Z	15	A05	I	I1Z	15	A05 <sup>2</sup>	I	I1Z
16	A04	I	I1Z	16	A04	I	I1Z	16	A04 <sup>2</sup>	I	I1Z
17	A03	I	I1Z	17	A03	I	I1Z	17	A03 <sup>2</sup>	I	I1Z
18	A02	I	I1Z	18	A02	I	I1Z	18	A02	I	I1Z
19	A01	I	I1Z	19	A01	I	I1Z	19	A01	I	I1Z
20	A00	I	I1Z	20	A00	I	I1Z	20	A00	I	I1Z
21	D00	I/O	I1Z,OZ3	21	D00	I/O	I1Z,OZ3	21	D00	I/O	I1Z,OZ3
22	D01	I/O	I1Z,OZ3	22	D01	I/O	I1Z,OZ3	22	D01	I/O	I1Z,OZ3
23	D02	I/O	I1Z,OZ3	23	D02	I/O	I1Z,OZ3	23	D02	I/O	I1Z,OZ3
24	WP	O	OT3	24	-IOIS16	O	OT3	24	-IOCS16	O	ON3
25	-CD2	O	Ground	25	-CD2	O	Ground	25	-CD2	O	Ground
26	-CD1	O	Ground	26	-CD1	O	Ground	26	-CD1	O	Ground
27	D11 <sup>1</sup>	I/O	I1Z,OZ3	27	D11 <sup>1</sup>	I/O	I1Z,OZ3	27	D11 <sup>1</sup>	I/O	I1Z,OZ3
28	D12 <sup>1</sup>	I/O	I1Z,OZ3	28	D12 <sup>1</sup>	I/O	I1Z,OZ3	28	D12 <sup>1</sup>	I/O	I1Z,OZ3
29	D13 <sup>1</sup>	I/O	I1Z,OZ3	29	D13 <sup>1</sup>	I/O	I1Z,OZ3	29	D13 <sup>1</sup>	I/O	I1Z,OZ3
30	D14 <sup>1</sup>	I/O	I1Z,OZ3	30	D14 <sup>1</sup>	I/O	I1Z,OZ3	30	D14 <sup>1</sup>	I/O	I1Z,OZ3
31	D15 <sup>1</sup>	I/O	I1Z,OZ3	31	D15 <sup>1</sup>	I/O	I1Z,OZ3	31	D15 <sup>1</sup>	I/O	I1Z,OZ3
32	-CE2 <sup>1</sup>	I	I3U	32	-CE2 <sup>1</sup>	I	I3U	32	-CS1 <sup>1</sup>	I	I3Z
33	-VS1	O	Ground	33	-VS1	O	Ground	33	-VS1	O	Ground
34	-IORD	I	I3U	34	-IORD	I	I3U	34	-IORD	I	I3Z

## CompactFlash Memory Card Product Manual

Table 4-1 Pin Assignments and Pin Type (continued)

PC Card Memory Mode				PC Card I/O Mode				True IDE Mode			
Pin Num	Signal Name	Pin Type	In, Out <sup>4</sup> Type	Pin Num	Signal Name	Pin Type	In, Out <sup>4</sup> Type	Pin Num	Signal Name	Pin Type	In, Out <sup>4</sup> Type
35	-IOWR	I	I3U	35	-IOWR	I	I3U	35	-IOWR	I	I3Z
36	-WE	I	I3U	36	-WE	I	I3U	36	-WE <sup>3</sup>	I	I3U
37	RDY/BSY	O	OT1	37	IREQ	O	OT1	37	INTRQ	O	OZ1
38	VCC		Power	38	VCC		Power	38	VCC		Power
39	-CSEL	I	I2Z	39	-CSEL	I	I2Z	39	-CSEL	I	I2U
40	-VS2	O	OPEN	40	-VS2	O	OPEN	40	-VS2	O	OPEN
41	RESET	I	I2Z	41	RESET	I	I2Z	41	-RESET	I	I2Z
42	-WAIT	O	OT1	42	-WAIT	O	OT1	42	IORDY	O	ON1
43	-INPACK	O	OT1	43	-INPACK	O	OT1	43	-INPACK	O	OZ1
44	-REG	I	I3U	44	-REG	I	I3U	44	-REG <sup>3</sup>	I	I3U
45	BVD2	I/O	I1U,OT1	45	-SPKR	I/O	I1U,OT1	45	-DASP	I/O	I1U,ON1
46	BVD1	I/O	I1U,OT1	46	-STSCHG	I/O	I1U,OT1	46	-PDIAG	I/O	I1U,ON1
47	D08 <sup>1</sup>	I/O	I1Z,OZ3	47	D08 <sup>1</sup>	I/O	I1Z,OZ3	47	D08 <sup>1</sup>	I/O	I1Z,OZ3
48	D09 <sup>1</sup>	I/O	I1Z,OZ3	48	D09 <sup>1</sup>	I/O	I1Z,OZ3	48	D09 <sup>1</sup>	I/O	I1Z,OZ3
49	D10 <sup>1</sup>	I/O	I1Z,OZ3	49	D10 <sup>1</sup>	I/O	I1Z,OZ3	49	D10 <sup>1</sup>	I/O	I1Z,OZ3
50	GND		Ground	50	GND		Ground	50	GND		Ground

- Note:
1. These signals are required only for 16 bit access and not required when installed in 8-bit systems. For lowest power dissipation, leave these signals open.
  2. Should be grounded by the host.
  3. Should be tied to VCC by the host.
  4. Please refer to section 4.3 for definitions of In, Out type.

## CompactFlash Memory Card Product Manual

**Table 4-2 Signal Description**

Signal Name	Dir.	Pin	Description
A10 - A0 (PC Card Memory Mode)	I	8, 10, 11, 12, 14, 15, 16, 17, 18, 19, 20	These address lines along with the -REG signal are used to select the following: The I/O port address registers within the CompactFlash Card, the memory mapped port address registers within the card, a byte in the card's information structure and its configuration control and status registers.
A10 - A0 (PC Card I/O Mode)			This signal is the same as the PC Card Memory Mode signal.
A2 - A0 (True IDE Mode)	I	18, 19, 20	In True IDE Mode only A[2:0] are used to select the one of eight registers in the Task File.
A10 - A3 (True IDE Mode)			In True IDE Mode, these remaining address lines should be grounded by the host.
BVD1 (PC Card Memory Mode)	I/O	46	This signal is asserted high as the BVD1 signal since a battery is not used with this product.
-STSCHG (PC Card I/O Mode) Status Changed			This signal is asserted low to alert the host to changes in the RDY/-BSY and Write Protect states, while the I/O interface is configured. Its use is controlled by the Card Config and Status Register.
-PDIAG (True IDE Mode)			In the True IDE Mode, this input / output is the Pass Diagnostic signal in the Master / Slave handshake protocol.
BVD2 (PC Card Memory Mode)	I/O	45	This output line is always driven to a high state in Memory Mode since a battery is not required for this product.
-SPKR (PC Card I/O Mode)			This output line is always driven to a high state in I/O Mode since this product does not support the audio function.
-DASP (True IDE Mode)			In the True IDE Mode, this input/output is the Disk Active/Slave Present signal in the Master/Slave handshake protocol.
-CD1, -CD2 (PC Card Memory Mode)	O	26, 25	These Card Detect pins are connected to ground on the CompactFlash Card. They are used by the host to determine if the card is fully inserted into its socket.
-CD1, -CD2 (PC Card I/O Mode)			This signal is the same for all modes.
-CD1, -CD2 (True IDE Mode)			This signal is the same for all modes.
-CE1, -CE2 (PC Card Memory Mode) Card Enable	I	7, 32	These input signals are used both to select the card and to indicate to the card whether a byte or a word operation is being performed. -CE2 always accesses the odd byte of the word. -CE1 accesses the even byte or the Odd byte of the word depending on A0 and -CE2. A multi-plexing scheme based on A0, -CE1, -CE2 allows 8 bit hosts to access all data on D0-D7. See Tables 4-11, 4-12, 4-15, and 4-16.
-CE1, -CE2 (PC Card I/O Mode) Card Enable			This signal is the same as the PC Card Memory Mode signal.
-CS0, -CS1 (True IDE Mode)			In the True IDE Mode -CS0 is the chip select for the task file registers while -CS1 is used to select the Alternate Status Register and the Device Control Register.

## CompactFlash Memory Card Product Manual

**Table 4-2 Signal Description (continued)**

Signal Name	Dir.	Pin	Description
-CSEL (PC Card Memory Mode)	I	39	This signal is not used for this mode.
-CSEL (PC Card I/O Mode)			This signal is not used for this mode.
-CSEL (True IDE Mode)			This internally pulled up signal is used to configure this device as a Master or a Slave when configured in the True IDE Mode. When this pin is grounded, this device is configured as a Master. When the pin is open, this device is configured as a Slave.
D15 - D00 (PC Card Memory Mode)	I/O	31, 30, 29, 28, 27, 49, 48, 47, 6, 5, 4, 3, 2, 23, 22, 21	These lines carry the Data, Commands and Status information between the host and the controller. D00 is the LSB of the Even Byte of the Word. D08 is the LSB of the Odd Byte of the Word.
D15 - D00 (PC Card I/O Mode)			This signal is the same as the PC Card Memory Mode signal.
D15 - D00 (True IDE Mode)			In True IDE Mode, all Task File operations occur in byte mode on the low order bus D00-D07 while all data transfers are 16 bit using D00-D15.
GND (PC Card Memory Mode)	--	1, 50	Ground.
GND (PC Card I/O Mode)			This signal is the same for all modes.
GND (True IDE Mode)			This signal is the same for all modes.
-INPACK (PC Card Memory Mode)	O	43	This signal is not used in this mode.
-INPACK (PC Card I/O Mode) Input Acknowledge			The Input Acknowledge signal is asserted by the CompactFlash Card when the card is selected and responding to an I/O read cycle at the address that is on the address bus. This signal is used by the host to control the enable of any input data buffers between the card and the CPU.
-INPACK (True IDE Mode)			In True IDE Mode this output signal is not used and should not be connected at the host.
-IORD (PC Card Memory Mode)	I	34	This signal is not used in this mode.
-IORD (PC Card I/O Mode)			This is an I/O Read strobe generated by the host. This signal gates I/O data onto the bus from the CompactFlash Card when the card is configured to use the I/O interface.
-IORD (True IDE Mode)			In True IDE Mode, this signal has the same function as in PC Card I/O Mode.



## CompactFlash Memory Card Product Manual

**Table 4-2 Signal Description (continued)**

Signal Name	Dir.	Pin	Description
-IOWR (PC Card Memory Mode)	I	35	This signal is not used in this mode.
-IOWR (PC Card I/O Mode)			The I/O Write strobe pulse is used to clock I/O data on the Card Data bus into the CompactFlash controller registers when the card is configured to use the I/O interface.  The clocking will occur on the negative to positive edge of the signal (trailing edge).
-IOWR (True IDE Mode)			In True IDE Mode, this signal has the same function as in PC Card I/O Mode.
-OE (PC Card Memory Mode)	I	9	This is an Output Enable strobe generated by the host interface. It is used to read data from the CompactFlash Card in Memory Mode and to read the CIS and configuration registers.
-OE (PC Card I/O Mode)			In PC Card I/O Mode, this signal is used to read the CIS and configuration registers.
-ATA SEL (True IDE Mode)			To enable True IDE Mode this input should be grounded by the host.
RDY/-BSY (PC Card Memory Mode)	O	37	In Memory Mode this signal is set high when the CompactFlash Card is ready to accept a new data transfer operation and held low when the card is busy. The Host memory card socket must provide a pull-up resistor.  At power up and at Reset, the RDY/-BSY signal is held low (busy) until the CompactFlash Card has completed its power up or reset function. No access of any type should be made to the CompactFlash Card during this time. The RDY/-BSY signal is held high (disabled from being busy) whenever the following condition is true: The CompactFlash Card has been powered up with +RESET continuously disconnected or asserted.
-IREQ (PC Card I/O Mode)			I/O Operation - After the CompactFlash Card has been configured for I/O operation, this signal is used as -Interrupt Request. This line is strobed low to generate a pulse mode interrupt or held low for a level mode interrupt.
INTRQ (True IDE Mode)			In True IDE Mode signal is the active high Interrupt Request to the host.
-REG (PC Card Memory Mode) Attribute Memory Select	I	44	This signal is used during Memory Cycles to distinguish between Common Memory and Register (Attribute) Memory accesses. High for Common Memory, Low for Attribute Memory.
-REG (PC Card I/O Mode)			The signal must also be active (low) during I/O Cycles when the I/O address is on the Bus.
-REG (True IDE Mode)			In True IDE Mode this input signal is not used and should be connected to VCC by the host.

## CompactFlash Memory Card Product Manual

**Table 4-2 Signal Description (continued)**

Signal Name	Dir.	Pin	Description
RESET (PC Card Memory Mode)	I	41	When the pin is high, this signal resets the CompactFlash Card. The card is Reset only at power up if this pin is left high or open from power-up. The card is also reset when the Soft Reset bit in the Card Configuration Option Register is set.
RESET (PC Card I/O Mode)			This signal is the same as the PC Card Memory Mode signal.
-RESET (True IDE Mode)			In the True IDE Mode this input pin is the active low hardware reset from the host.
VCC (PC Card Memory Mode)	--	13, 38	+5 V, +3.3 V power.
VCC (PC Card I/O Mode)			This signal is the same for all modes.
VCC (True IDE Mode)			This signal is the same for all modes.
-VS1 -VS2 (PC Card Memory Mode)	O	33 40	Voltage Sense Signals. -VS1 is grounded so that the CompactFlash Card CIS can be read at 3.3 volts and -VS2 is open and reserved by PCMCIA for a secondary voltage.
-VS1 -VS2 (PC Card I/O Mode)			This signal is the same for all modes.
-VS1 -VS2 (True IDE Mode)			This signal is the same for all modes.
-WAIT (PC Card Memory Mode)	O	42	The -WAIT signal is driven low by the CompactFlash Card to signal the host to delay completion of a memory or I/O cycle that is in progress.
-WAIT (PC Card I/O Mode)			This signal is the same as the PC Card Memory Mode signal.
IORDY (True IDE Mode)			In True IDE Mode this output signal may be used as IORDY.
-WE (PC Card Memory Mode)	I	36	This is a signal driven by the host and used for strobing memory write data to the registers of the CompactFlash Card when the card is configured in the memory interface mode. It is also used for writing the configuration registers.
-WE (PC Card I/O Mode)			In PC Card I/O Mode, this signal is used for writing the configuration registers.
-WE (True IDE Mode)			In True IDE Mode this input signal is not used and should be connected to VCC by the host.
WP (PC Card Memory Mode) Write Protect	O	24	Memory Mode - The CompactFlash Card does not have a write protect switch. This signal is held low after the completion of the reset initialization sequence.
-IOIS16 (PC Card I/O Mode)			I/O Operation - When the CompactFlash Card is configured for I/O Operation, Pin 24 is used for the -I/O Selected is 16 Bit Port (-IOIS16) function. A Low signal indicates that a 16 bit or odd byte only operation can be performed at the addressed port.
-IOCS16 (True IDE Mode)			In True IDE Mode this output signal is asserted low when this device is expecting a word data transfer cycle.

# CompactFlash Memory Card Product Manual

## 4.3 Electrical Specification

The following table defines all D.C. Characteristics for the CompactFlash Memory Card Series.

Unless otherwise stated, conditions are:

<b>SDCFB-XX</b>	<b>SDCFBI-XX</b>
<b>SDCF2B-XX</b>	<b>SDCF2BI-XX</b>
V <sub>cc</sub> = 5V ±10%	V <sub>cc</sub> = 5V ± 5%
V <sub>cc</sub> = 3.3V ± 5%	V <sub>cc</sub> = 3.3V ± 5%
T <sub>a</sub> = 0°C to 60°C	T <sub>a</sub> = -40°C to 85°C

Absolute Maximum conditions are:

V<sub>cc</sub> = -0.3V min. to 7.0V max.

V\* = -0.5V min. to V<sub>cc</sub> + 0.5V max.

\* Voltage on any pin except V<sub>cc</sub> with respect to GND.

### 4.3.1 Input Leakage Current

Note: In the table below, x refers to the characteristics described in section 4.3.2. For example, I1U indicates a pull up resistor with a type 1 input characteristic.

Type	Parameter	Symbol	Conditions	MIN	TYP	MAX	Units
IxZ	Input Leakage Current	IL	V <sub>ih</sub> = V <sub>cc</sub> / V <sub>il</sub> = Gnd	-1		1	μA
IxU	Pull Up Resistor	RPU1	V <sub>cc</sub> = 5.0V	50k		500k	Ohm
IxD	Pull Down Resistor	RPD1	V <sub>cc</sub> = 5.0V	50k		500k	Ohm

Note: The minimum pullup resistor leakage current meets the PCMCIA specification of 10k ohms but is intentionally higher in the CompactFlash Memory Card Series product to reduce power use.

### 4.3.2 Input Characteristics

Type	Parameter	Symbol	MIN	TYP	MAX	MIN	TYP	MAX	Units
			VCC = 3.3 V			VCC = 5.0 V			
1	Input Voltage CMOS	V <sub>ih</sub> V <sub>il</sub>	2.4		0.6	2.4		0.8	Volts
2	Input Voltage CMOS	V <sub>ih</sub> V <sub>il</sub>	1.5		0.6	2.0		0.8	Volts
3	Input Voltage CMOS Schmitt Trigger	V <sub>th</sub> V <sub>tl</sub>		1.8 1.0			2.8 2.0		Volts

## CompactFlash Memory Card Product Manual

### 4.3.3 Output Drive Type

Note: In the table below, x refers to the characteristics described in section 4.3.4. For example, OT3 refers to Totempole output with a type 3 output drive characteristic.

Type	Output Type	Valid Conditions
OTx	Totempole	Ioh & Iol
OZx	Tri-State N-P Channel	Ioh & Iol
OPx	P-Channel Only	Ioh Only
ONx	N-Channel Only	Iol Only

### 4.3.4 Output Drive Characteristics

Type	Parameter	Symbol	Conditions	MIN	TYP	MAX	Units
1	Output Voltage	Voh	Ioh = -4 mA	Vcc			Volts
		Vol	Iol = 4 mA	-0.8V		Gnd +0.4V	
2	Output Voltage	Voh	Ioh = -8 mA	Vcc			Volts
		Vol	Iol = 8 mA	-0.8V		Gnd +0.4V	
3	Output Voltage	Voh	Ioh = -8 mA	Vcc			Volts
		Vol	Iol = 8 mA	-0.8V		Gnd +0.4V	
X	Tri-State Leakage Current	Ioz	Vol = Gnd Voh = Vcc	-10		10	µA

# CompactFlash Memory Card Product Manual

## 4.3.5 Interface/Bus Timing

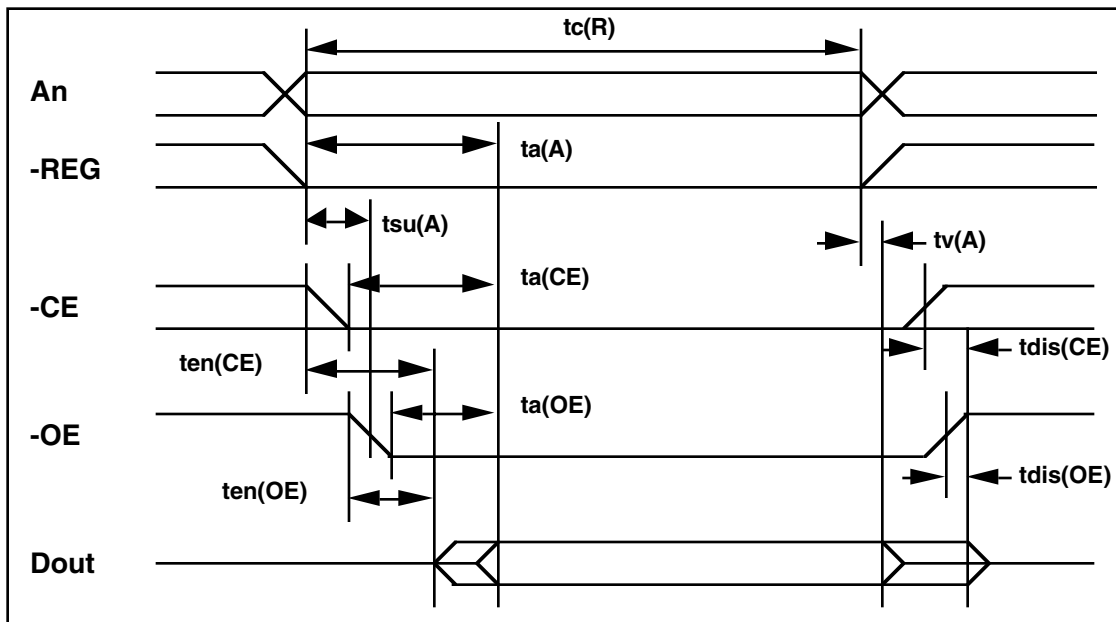
There are two types of bus cycles and timing sequences that occur in the PCMCIA type interface, a direct mapped I/O transfer and a memory access. The two timing sequences are explained in detail in the PCMCIA PC Card Standard Release 2.1. The CompactFlash Memory Card conforms to the timing in that reference document.

## 4.3.6 Attribute Memory Read Timing Specification

The Attribute Memory access time is defined as 300 ns. Detailed timing specifications are shown in Table 4-3.

**Table 4-3 Attribute Memory Read Timing**

Speed Version	Item	Symbol	IEEE Symbol	300 ns	
				Min ns.	Max ns.
	Read Cycle Time	tc(R)	tAVAV	300	
	Address Access Time	ta(A)	tAVQV		300
	Card Enable Access Time	ta(CE)	tELQV		300
	Output Enable Access Time	ta(OE)	tGLQV		150
	Output Disable Time from CE	tdis(CE)	tEHQZ		100
	Output Disable Time from OE	tdis(OE)	tGHQZ		100
	Address Setup Time	tsu(A)	tAVWL	30	
	Output Enable Time from CE	ten(CE)	tELQNZ	5	
	Output Enable Time from OE	ten(OE)	tGLQNZ	5	
	Data Valid from Address Change	tv(A)	tAXQX	0	



**Figure 4-1 Attribute Memory Read Timing Diagram**

Notes: All times are in nanoseconds. Dout signifies data provided by the CompactFlash Memory Card to the system. The -CE signal or both the -OE signal and the -WE signal must be de-asserted between consecutive cycle operations.

# CompactFlash Memory Card Product Manual

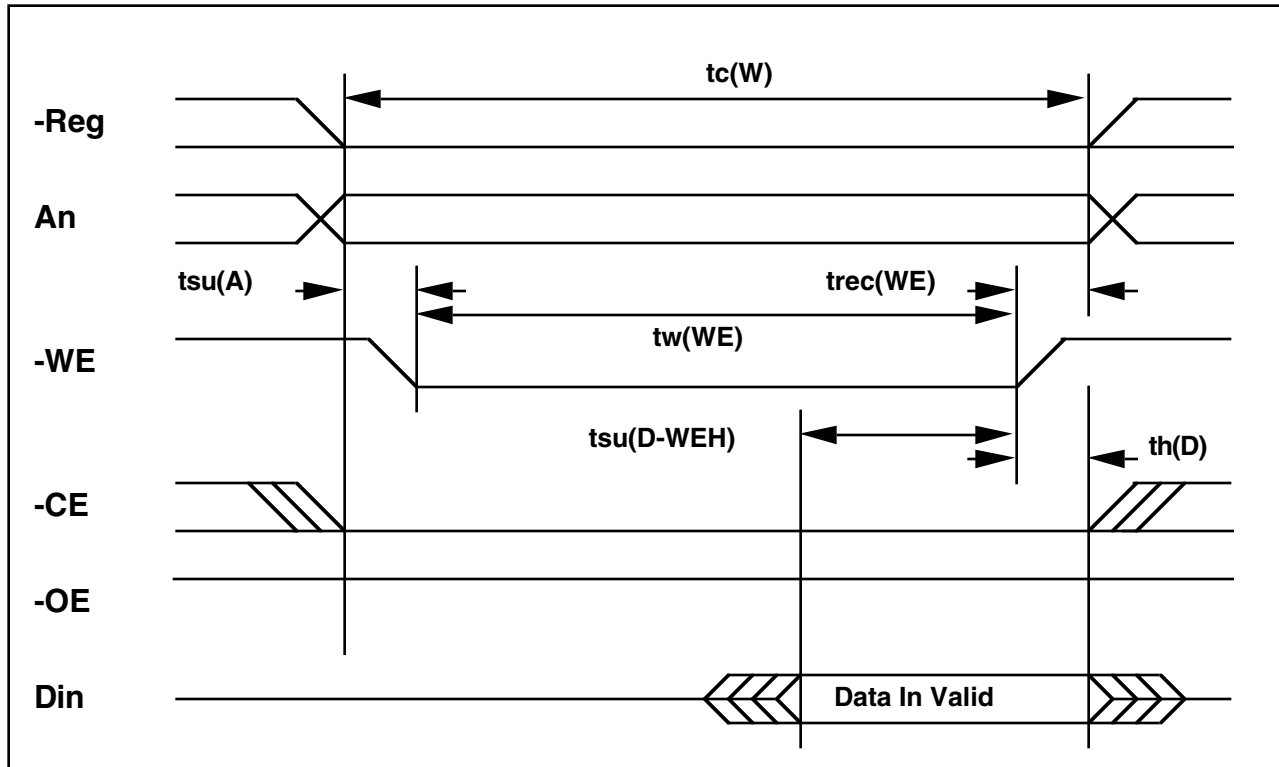
## 4.3.7 Attribute Memory Write Timing Specification

The Card Configuration write access time is defined as 250 ns. Detailed timing specifications are shown in Table 4-4.

Note: SanDisk does not allow writing from the Host to CIS Memory. Only writes to the Configuration register are allowed.

**Table 4-4 Attribute Memory Write Timing**

Speed Version	Item	Symbol	IEEE Symbol	250 ns	
				Min ns	Max ns
	Write Cycle Time	tc(W)	tAVAV	250	
	Write Pulse Width	tw(WE)	tWLWH	150	
	Address Setup Time	tsu(A)	tAVWL	30	
	Write Recovery Time	trec(WE)	tWMAX	30	
	Data Setup Time for WE	tsu(D-WEH)	tDVWH	80	
	Data Hold Time	th(D)	tWMDX	30	



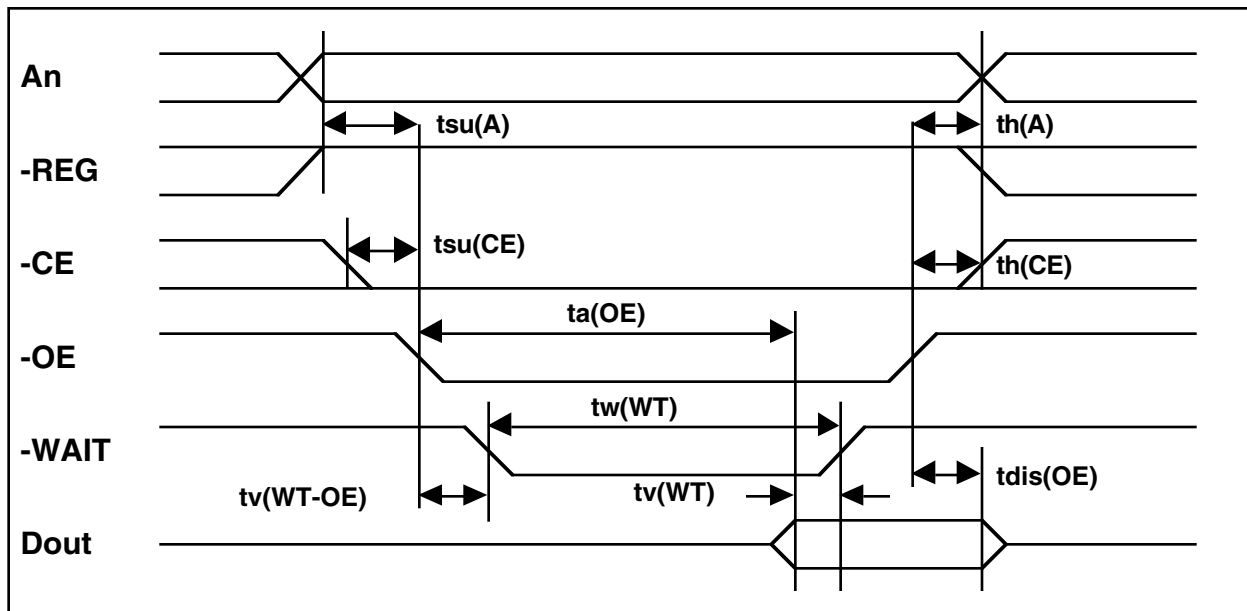
**Figure 4-2 Attribute Memory Write Timing Diagram**

Notes: All times are in nanoseconds.  
Din signifies data provided by the system to the CompactFlash Memory Card.

## 4.3.8 Common Memory Read Timing Specification

**Table 4-5 Common Memory Read Timing**

Item	Symbol	IEEE Symbol	Min ns.	Max ns.
Output Enable Access Time	ta(OE)	tGLQV		125
Output Disable Time from OE	tdis(OE)	tGHQZ		100
Address Setup Time	tsu(A)	tAVGL	30	
Address Hold Time	th(A)	tGHAX	20	
CE Setup before OE	tsu(CE)	tELGL	0	
CE Hold following OE	th(CE)	tGHEH	20	
Wait Delay Falling from OE	tv(WT-OE)	tGLWTV		35
Data Setup for Wait Release	tv(WT)	tQVWTH		0
Wait Width Time (Default Speed)	tw(WT)	tWTLWTH		350



**Figure 4-3 Common Memory Read Timing Diagram**

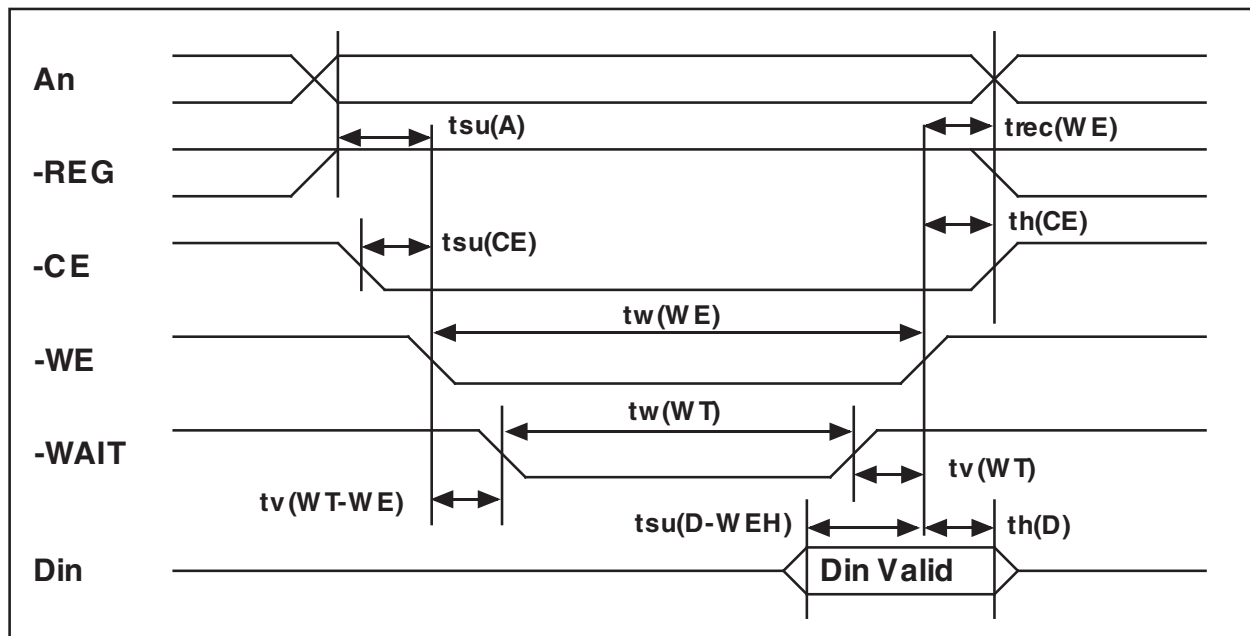
Notes: The maximum load on -WAIT is 1 LSTTL with 50pF total load. All times are in nanoseconds. Dout signifies data provided by the CompactFlash Memory Card to the system. The -WAIT signal may be ignored if the -OE cycle to cycle time is greater than the Wait Width time. The Max Wait Width time (in the slowest mode) can be determined from the Card Information Structure.

# CompactFlash Memory Card Product Manual

## 4.3.9 Common Memory Write Timing Specification

**Table 4-6 Common Memory Write Timing**

Item	Symbol	IEEE Symbol	Min ns.	Max ns.
Data Setup before WE	tsu(D-WEH)	tDVWH	80	
Data Hold following WE	th(D)	tWMDX	30	
WE Pulse Width	tw(WE)	tWLWH	150	
Address Setup Time	tsu(A)	tAVWL	30	
CE Setup before WE	tsu(CE)	tELWL	0	
Write Recovery Time	trec(WE)	tWMAX	30	
CE Hold following WE	th(CE)	tGHEH	20	
Wait Delay Falling from WE	tv(WT-WE)	tWLWTV		35
WE High from Wait Release	tv(WT)	tWTHWH	0	
Wait Width Time (Default Speed)	tw(WT)	tWTLWTH		350



**Figure 4-4 Common Memory Write Timing Diagram**

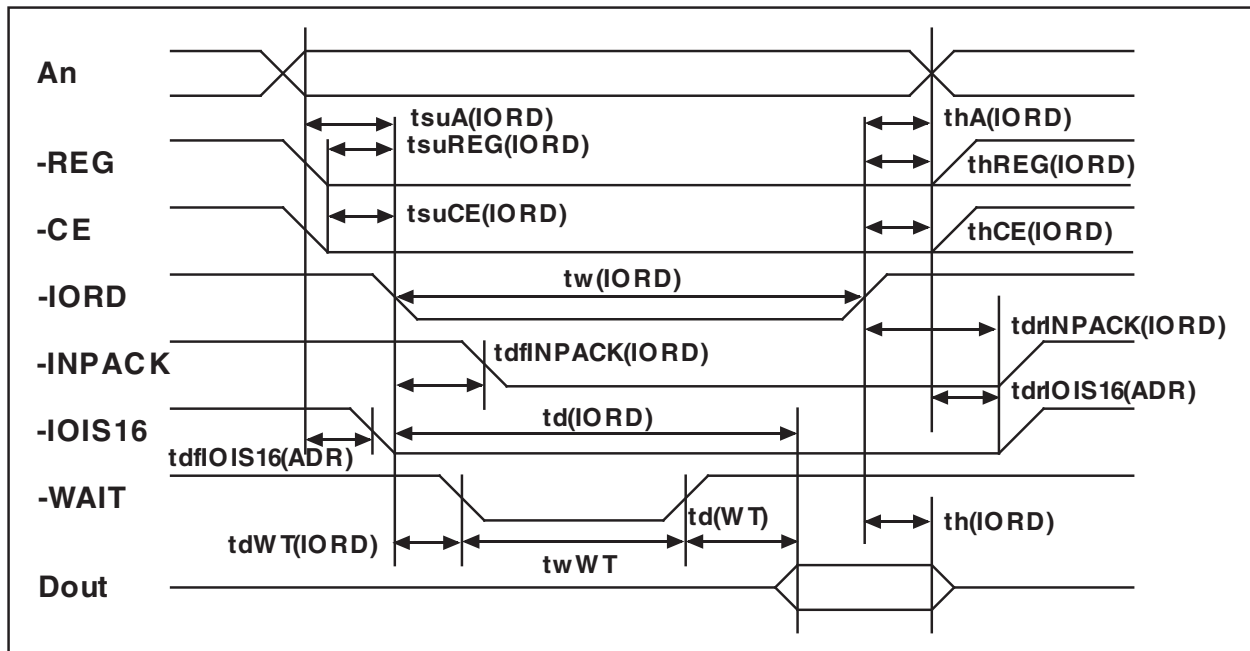
Notes: The maximum load on -WAIT is 1 LSTTL with 50pF total load. All times are in nanoseconds.  
 Din signifies data provided by the system to the CompactFlash Memory Card.  
 The -WAIT signal may be ignored if the -WE cycle to cycle time is greater than the Wait Width time.  
 The Max Wait Width time (in the slowest mode) can be determined from the Card Information Structure.



## 4.3.10 I/O Input (Read) Timing Specification

**Table 4-7 I/O Read Timing**

Item	Symbol	IEEE Symbol	Min ns.	Max ns.
Data Delay after IORD	td(IORD)	tIGLQV		100
Data Hold following IORD	th(IORD)	tIGHQX	0	
IORD Width Time	tw(IORD)	tIGLIGH	165	
Address Setup before IORD	tsuA(IORD)	tAVIGL	70	
Address Hold following IORD	thA(IORD)	tIGHAX	20	
CE Setup before IORD	tsuCE(IORD)	tELIGL	5	
CE Hold following IORD	thCE(IORD)	tIGHEH	20	
REG Setup before IORD	tsuREG(IORD)	tRGLIGL	5	
REG Hold following IORD	thREG(IORD)	tIGHRGH	0	
INPACK Delay Falling from IORD	tdfINPACK(IORD)	tIGLIAL	0	45
INPACK Delay Rising from IORD	tdrINPACK(IORD)	tIGHIAH		45
IOIS16 Delay Falling from Address	tdfIOIS16(ADR)	tAVISL		35
IOIS16 Delay Rising from Address	tdrIOIS16(ADR)	tAVISH		35
Wait Delay Falling from IORD	tdWT(IORD)	tIGLWTL		35
Data Delay from Wait Rising	td(WT)	tWTHQV		0
Wait Width Time (Default Speed)	tw(WT)	tWTLWTH		350



**Figure 4-5 I/O Read Timing Diagram**

Notes: The maximum load on -WAIT, -INPACK and -IOIS16 is 1 LSTTL with 50pF total load. All times are in nanoseconds.

Minimum time from -WAIT high to -IORD high is 0 nsec, but minimum -IORD width must still be met.

Dout signifies data provided by the CompactFlash Memory Card to the system.

# CompactFlash Memory Card Product Manual

## 4.3.11 I/O Output (Write) Timing Specification

Table 4-8 I/O Write Timing

Item	Symbol	IEEE Symbol	Min ns.	Max ns.
Data Setup before IOWR	tsu(IOWR)	tDVIWH	60	
Data Hold following IOWR	th(IOWR)	tIWHDX	30	
IOWR Width Time	tw(IOWR)	tIWLWH	165	
Address Setup before IOWR	tsuA(IOWR)	tAVIWL	70	
Address Hold following IOWR	thA(IOWR)	tIWHAX	20	
CE Setup before IOWR	tsuCE(IOWR)	tELIWL	5	
CE Hold following IOWR	thCE(IOWR)	tIWHEH	20	
REG Setup before IOWR	tsuREG(IOWR)	tRGLIWL	5	
REG Hold following IOWR	thREG(IOWR)	tIWHRGH	0	
IOIS16 Delay Falling from Address	tdfIOIS16(ADR)	tAVISL		35
IOIS16 Delay Rising from Address	tdrIOIS16(ADR)	tAVISH		35
Wait Delay Falling from IOWR	tdWT(IOWR)	tIWLWTL		35
IOWR high from Wait high	tdrIOWR(WT)	tWTJIWH	0	
Wait Width Time (Default Speed) (Set Feature Speed <68 mA.)	tw(WT)	tWTLWTH		350 700

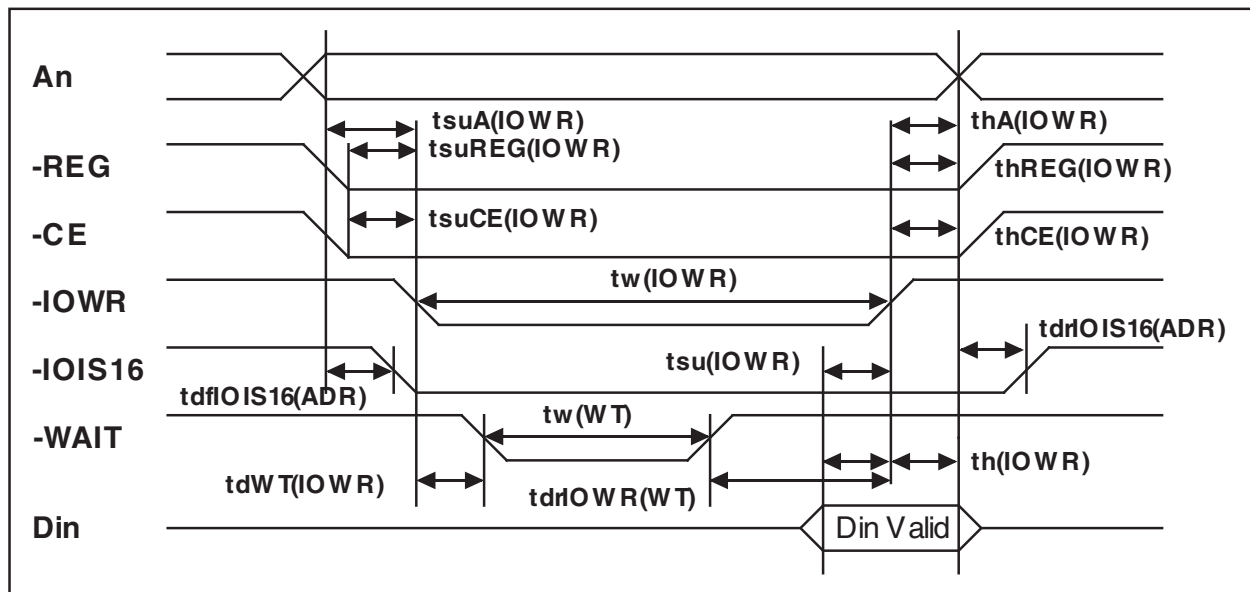


Figure 4-6 I/O Write Timing Diagram

Notes: The maximum load on -WAIT, -INPACK, and -IOIS16 is 1 LSTTL with 50pF total load. All times are in nanoseconds.

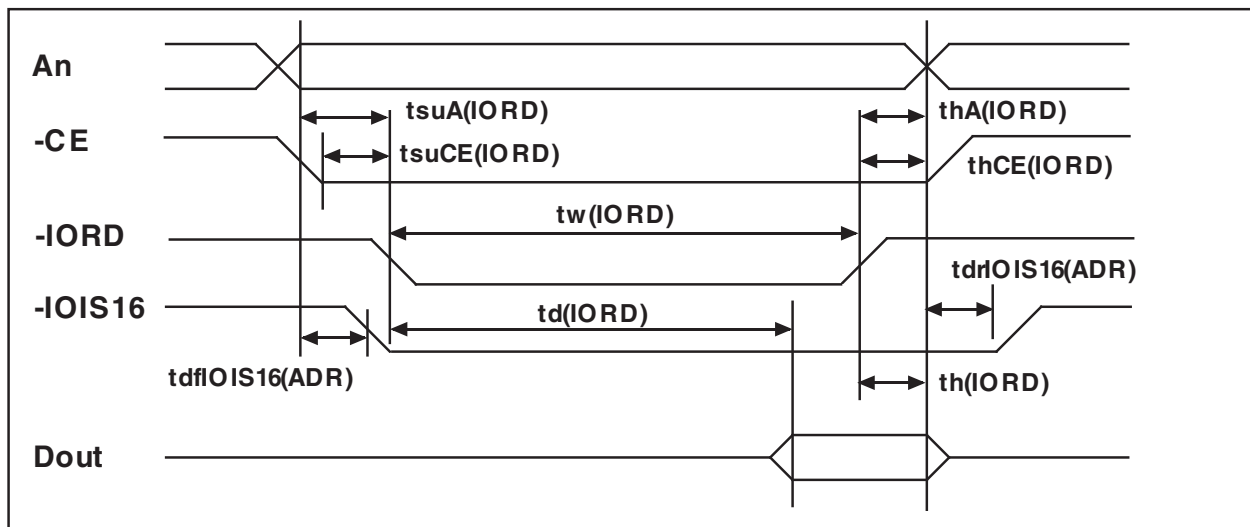
Minimum time from -WAIT high to -IOWR high is 0 nsec, but minimum -IOWR width must still be met.

Din signifies data provided by the system to the CompactFlash Memory Card.

## 4.3.12 True IDE Mode I/O Input (Read) Timing Specification

**Table 4-9 True IDE Mode I/O Read Timing**

Item	Symbol	IEEE Symbol	Min ns.	Max ns.
Data Delay after IORD	td(IORD)	tIGLQV		100
Data Hold following IORD	th(IORD)	tIGHQX	0	
IORD Width Time	tw(IORD)	tIGLIGH	165	
Address Setup before IORD	tsuA(IORD)	tAVIGL	70	
Address Hold following IORD	thA(IORD)	tIGHAX	20	
CE Setup before IORD	tsuCE(IORD)	tELIGL	5	
CE Hold following IORD	thCE(IORD)	tIGHEH	20	
IOIS16 Delay Falling from Address	tdfIOIS16(ADR)	tAVISL		35
IOIS16 Delay Rising from Address	tdrIOIS16(ADR)	tAVISH		35



**Figure 4-7 True IDE Mode I/O Read Timing Diagram**

Notes: The maximum load on -IOIS16 is 1 LSTTL with 50pF total load. All times are in nanoseconds. Minimum time from -WAIT high to -IORD high is 0 nsec, but minimum -IORD width must still be met. Dout signifies data provided by the CompactFlash Memory Card to the system.

# CompactFlash Memory Card Product Manual

## 4.3.13 True IDE Mode I/O Output (Write) Timing Specification

Table 4-10 True IDE Mode I/O Write Timing

Item	Symbol	IEEE Symbol	Min ns.	Max ns.
Data Setup before IOWR	tsu(IOWR)	tDVIWH	60	
Data Hold following IOWR	th(IOWR)	tIWHDX	30	
IOWR Width Time	tw(IOWR)	tIWLWH	165	
Address Setup before IOWR	tsuA(IOWR)	tAVIWL	70	
Address Hold following IOWR	thA(IOWR)	tIWHAX	20	
CE Setup before IOWR	tsuCE(IOWR)	tELIWL	5	
CE Hold following IOWR	thCE(IOWR)	tIWHEH	20	
IOIS16 Delay Falling from Address	tdfIOIS16(ADR)	tAVISL		35
IOIS16 Delay Rising from Address	tdrIOIS16(ADR)	tAVISH		35

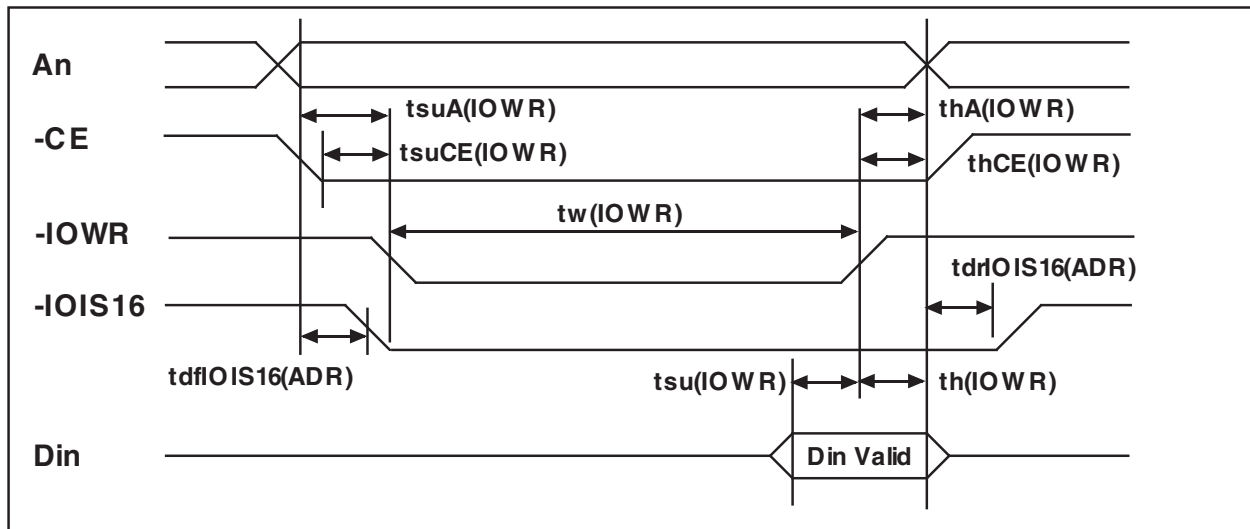


Figure 4-8 True IDE Mode I/O Write Timing Diagram

Notes: The maximum load on -IOIS16 is 1 LSTTL with 50pF total load. All times are in nanoseconds. Minimum time from -WAIT high to -IOWR high is 0 nsec, but minimum -IOWR width must still be met. Din signifies data provided by the system to the CompactFlash Memory Card.

## 4.4 Card Configuration

The CompactFlash Memory Cards are identified by appropriate information in the Card Information Structure (CIS). The following configuration registers are used to coordinate the I/O spaces and the Interrupt level of cards that are located in the system. In addition, these registers provide a method for accessing status

information about the CompactFlash Card that may be used to arbitrate between multiple interrupt sources on the same interrupt level or to replace status information that appears on dedicated pins in memory cards that have alternate use in I/O cards.

**Table 4-11 Registers and Memory Space Decoding**

-CE2	-CE1	-REG	-OE	-WE	A10	A9	A8-A4	A3	A2	A1	A0	SELECTED SPACE
1	1	X	X	X	X	X	XX	X	X	X	X	Standby
X	0	0	0	1	X	1	XX	X	X	X	0	Configuration Registers Read
1	0	1	0	1	X	X	XX	X	X	X	X	Common Memory Read (8 Bit D7-D0)
0	1	1	0	1	X	X	XX	X	X	X	X	Common Memory Read (8 Bit D15-D8)
0	0	1	0	1	X	X	XX	X	X	X	0	Common Memory Read (16 Bit D15-D0)
X	0	0	1	0	X	1	XX	X	X	X	0	Configuration Registers Write
1	0	1	1	0	X	X	XX	X	X	X	X	Common Memory Write (8 Bit D7-D0)
0	1	1	1	0	X	X	XX	X	X	X	X	Common Memory Write (8 Bit D15-D8)
0	0	1	1	0	X	X	XX	X	X	X	0	Common Memory Write (16 Bit D15-D0)
X	0	0	0	1	0	0	XX	X	X	X	0	Card Information Structure Read
1	0	0	1	0	0	0	XX	X	X	X	0	Invalid Access (CIS Write)
1	0	0	0	1	X	X	XX	X	X	X	1	Invalid Access (Odd Attribute Read)
1	0	0	1	0	X	X	XX	X	X	X	1	Invalid Access (Odd Attribute Write)
0	1	0	0	1	X	X	XX	X	X	X	X	Invalid Access (Odd Attribute Read)
0	1	0	1	0	X	X	XX	X	X	X	X	Invalid Access (Odd Attribute Write)

### Configuration Registers Decoding

-CE2	-CE1	-REG	-OE	-WE	A10	A9	A8-A4	A3	A2	A1	A0	SELECTED REGISTER
X	0	0	0	1	0	1	00	0	0	0	0	Configuration Option Reg Read
X	0	0	1	0	0	1	00	0	0	0	0	Configuration Option Reg Write
X	0	0	0	1	0	1	00	0	0	1	0	Card Status Register Read
X	0	0	1	0	0	1	00	0	0	1	0	Card Status Register Write
X	0	0	0	1	0	1	00	0	1	0	0	Pin Replacement Register Read
X	0	0	1	0	0	1	00	0	1	0	0	Pin Replacement Register Write
X	0	0	0	1	0	1	00	0	1	1	0	Socket and Copy Register Read
X	0	0	1	0	0	1	00	0	1	1	0	Socket and Copy Register Write

Note: The location of the card configuration registers should always be read from the CIS since these locations may vary in future products. No writes should be performed to the CompactFlash Memory Card attribute memory except to the card configuration register addresses. All other attribute memory locations are reserved.

# CompactFlash Memory Card Product Manual

## 4.4.1 Attribute Memory Function

Attribute memory is a space where CompactFlash Memory Card identification and configuration information is stored, and is limited to 8-bit wide accesses only at even addresses. The card configuration registers are also located here.

For the Attribute Memory Read function, signals -REG and -OE must be active and -WE inactive

during the cycle. As in the Main Memory Read functions, the signals -CE1 and -CE2 control the even-byte and odd-byte address, but only the even-byte data is valid during the Attribute Memory access. Refer to Table 4-12 below for signal states and bus validity for the Attribute Memory function.

**Table 4-12 Attribute Memory Function**

Function Mode	-REG	-CE2	-CE1	A9	A0	-OE	-WE	D15-D8	D7-D0
Standby Mode	X	H	H	X	X	X	X	High Z	High Z
Read Byte Access CIS ROM (8 bits)	L	H	L	L	L	L	H	High Z	Even Byte
Write Byte Access CIS (8 bits) (Invalid)	L	H	L	L	L	H	L	Don't Care	Even Byte
Read Byte Access Configuration (8 bits)	L	H	L	H	L	L	H	High Z	Even Byte
Write Byte Access Configuration (8 bits)	L	H	L	H	L	H	L	Don't Care	Even Byte
Read Word Access CIS (16 bits)	L	L	L	L	X	L	H	Not Valid	Even Byte
Write Word Access CIS (16 bits) (Invalid)	L	L	L	L	X	H	L	Don't Care	Even Byte
Read Word Access Configuration (16 bits)	L	L	L	H	X	L	H	Not Valid	Even Byte
Write Word Access Configuration (16 bits)	L	L	L	H	X	H	L	Don't Care	Even Byte

Note: The -CE signal or both the -OE signal and the -WE signal must be de-asserted between consecutive cycle operations.

## 4.4.2 Configuration Option Register (Address 200h in Attribute Memory)

The Configuration Option Register is used to configure the cards interface, address decoding and interrupt and to issue a soft reset to the CompactFlash Memory Card.

Operation	D7	D6	D5	D4	D3	D2	D1	D0
R/W	SRESET	LevIREQ	Conf5	Conf4	Conf3	Conf2	Conf1	Conf0

**SRESET** Soft Reset - Setting this bit to one (1), waiting the minimum reset width time and returning to zero (0) places the CompactFlash Memory Card in the Reset state. Setting this bit to one (1) is equivalent to assertion of the +RESET signal except that the SRESET bit is not cleared. Returning this bit to zero (0) leaves the CompactFlash Memory Card in the same un-configured, Reset state as following power-up and hardware reset. This bit is set to zero (0) by power-up and hardware reset. Using the PCMCIA Soft Reset is considered a hard Reset by the ATA Commands. Contrast with Soft Reset in the Device Control Register.

**LevIREQ** This bit is set to one (1) when Level Mode Interrupt is selected, and zero (0) when Pulse Mode is selected. Set to zero (0) by Reset.

**Conf5 - Conf0** Configuration Index. Set to zero (0) by reset. It's used to select operation mode of the CompactFlash Memory Card as shown below.

Note: Conf5 and Conf4 are reserved and must be written as zero (0)

**Table 4-13 Card Configurations**

Conf5	Conf4	Conf3	Conf2	Conf1	Conf0	Disk Card Mode
0	0	0	0	0	0	Memory Mapped
0	0	0	0	0	1	I/O Mapped, Any 16 byte system decoded boundary
0	0	0	0	1	0	I/O Mapped, 1F0-1F7/3F6-3F7
0	0	0	0	1	1	I/O Mapped, 170-177/376-377

## 4.4.3 Card Configuration and Status Register (Address 202h in Attribute Memory)

The Card Configuration and Status Register contains information about the Card's condition.

Card Configuration and Status Register Organization:

Operation	D7	D6	D5	D4	D3	D2	D1	D0
Read	Changed	SigChg	IOis8	0	0	PwrDwn	Int	0
Write	0	SigChg	IOis8	0	0	PwrDwn	0	0

## CompactFlash Memory Card Product Manual

- Changed** Indicates that one or both of the Pin Replacement register CRdy, or CWProt bits are set to one (1). When the Changed bit is set, -STSCHG Pin 46 is held low if the SigChg bit is a One (1) and the CompactFlash Memory Card is configured for the I/O interface.
- SigChg** This bit is set and reset by the host to enable and disable a state-change “signal” from the Status Register, the Changed bit control pin 46 the Changed Status signal. If no state change signal is desired, this bit should be set to zero (0) and pin 46 (-STSCHG) signal will be held high while the CompactFlash Memory Card is configured for I/O.
- IOis8** The host sets this bit to a one (1) if the CompactFlash Memory Card is to be configured in an 8 bit I/O mode. The CompactFlash Card is always configured for both 8- and 16-bit I/O, so this bit is ignored.
- PwrDwn** This bit indicates whether the host requests the CompactFlash Memory Card to be in the power saving or active mode. When the bit is one (1), the CompactFlash Card enters a power down mode. When zero (0), the host is requesting the CompactFlash Card to enter the active mode. The PCMCIA Rdy/-Bsy value becomes BUSY when this bit is changed. Rdy/-Bsy will not become Ready until the power state requested has been entered. The CompactFlash Card automatically powers down when it is idle and powers back up when it receives a command.
- Int** This bit represents the internal state of the interrupt request. This value is available whether or not I/O interface has been configured. This signal remains true until the condition which caused the interrupt request has been serviced. If interrupts are disabled by the -IEN bit in the Device Control Register, this bit is a zero (0).

---

#### 4.4.4 Pin Replacement Register (Address 204h in Attribute Memory)

Operation	D7	D6	D5	D4	D3	D2	D1	D0
Read	0	0	CRdy/-Bsy	CWProt	1	1	RRdy/-Bsy	RWProt
Write	0	0	CRdy/-Bsy	CWProt	0	0	MRdy/-Bsy	MWProt

- CRdy/-Bsy** This bit is set to one (1) when the bit RRdy/-Bsy changes state. This bit can also be written by the host.
- CWProt** This bit is set to one (1) when the RWprot changes state. This bit may also be written by the host.
- RRdy/-Bsy** This bit is used to determine the internal state of the Rdy/-Bsy signal. This bit may be used to determine the state of the Ready/-Busy as this pin has been reallocated for use as Interrupt Request on an I/O card. When written, this bit acts as a mask for writing the corresponding bit CRdy/-Bsy.
- RWProt** This bit is always zero (0) since the CompactFlash Memory Card does not have a Write Protect switch. When written, this bit acts as a mask for writing the corresponding bit CWProt.
- MRdy/-Bsy** This bit acts as a mask for writing the corresponding bit CRdy/-Bsy.
- MWProt** This bit when written acts as a mask for writing the corresponding bit CWProt.



# CompactFlash Memory Card Product Manual

**Table 4-14 Pin Replacement Changed Bit/Mask Bit Values**

Initial Value of (C) Status	Written by Host		Final “C” Bit	Comments
	“C” Bit	“M” Bit		
0	X	0	0	Unchanged
1	X	0	1	Unchanged
X	0	1	0	Cleared by Host
X	1	1	1	Set by Host

## 4.4.5 Socket and Copy Register (Address 206h in Attribute Memory)

This register contains additional configuration information. This register is always written by the system before writing the card’s Configuration Index Register.

Socket and Copy Register Organization:

Operation	D7	D6	D5	D4	D3	D2	D1	D0
Read	Reserved	0	0	Drive #	0	0	0	0
Write	0	0	0	Drive # (0)	X	X	X	X

**Reserved** This bit is reserved for future standardization. This bit must be set to zero (0) by the software when the register is written.

**Drive #** This bit indicates the drive number of the card if twin card configuration is supported.

**X** The socket number is ignored by the CompactFlash Memory Card.

# CompactFlash Memory Card Product Manual

## 4.5 I/O Transfer Function

### 4.5.1 I/O Function

The I/O transfer to or from the CompactFlash Memory Card can be either 8 or 16 bits. When a 16-bit accessible port is addressed, the signal -IOIS16 is asserted by the CompactFlash Card. Otherwise, the -IOIS16 signal is de-asserted. When a 16 bit transfer is attempted, and the -IOIS16 signal is not asserted by the CompactFlash Card, the system must generate a pair of 8-bit references to access the word's even

byte and odd byte. The CompactFlash Card permits both 8 and 16 bit accesses to all of its I/O addresses, so -IOIS16 is asserted for all addresses to which the CompactFlash Card responds.

The CompactFlash Memory Card may request the host to extend the length of an input cycle until data is ready by asserting the -WAIT signal at the start of the cycle.

**Table 4-15 I/O Function**

Function Code	-REG	-CE2	-CE1	A0	-IORD	-IOWR	D15-D8	D7-D0
Standby Mode	X	H	H	X	X	X	High Z	High Z
Byte Input Access (8 bits)	L L	H H	L L	L H	L L	H H	High Z High Z	Even-Byte Odd-Byte
Byte Output Access (8 bits)	L L	H H	L L	L H	H H	L L	Don't Care Don't Care	Even-Byte Odd-Byte
Word Input Access (16 bits)	L	L	L	L	L	H	Odd-Byte	Even-Byte
Word Output Access (16 bits)	L	L	L	L	H	L	Odd-Byte	Even-Byte
I/O Read Inhibit	H	X	X	X	L	H	Don't Care	Don't Care
I/O Write Inhibit	H	X	X	X	H	L	High Z	High Z
High Byte Input Only (8 bits)	L	L	H	X	L	H	Odd-Byte	High Z
High Byte Output Only (8 bits)	L	L	H	X	H	L	Odd-Byte	Don't Care

## 4.6 Common Memory Transfer Function

### 4.6.1 Common Memory Function

The Common Memory transfer to or from the CompactFlash Memory Card can be either 8 or 16 bits.

The CompactFlash Memory Card permits both 8 and 16 bit accesses to all of its Common Memory addresses.

The CompactFlash Memory Card may request the host to extend the length of a memory write cycle or extend the length of a memory read cycle until data is ready by asserting the -WAIT signal at the start of the cycle.

**Table 4-16 Common Memory Function**

Function Code	-REG	-CE2	-CE1	A0	-OE	-WE	D15-D8	D7-D0
Standby Mode	X	H	H	X	X	X	High Z	High Z
Byte Read Access (8 bits)	H H	H H	L L	L H	L L	H H	High Z High Z	Even-Byte Odd-Byte
Byte Write Access (8 bits)	H H	H H	L L	L H	H H	L L	Don't Care Don't Care	Even-Byte Odd-Byte
Word Read Access (16 bits)	H	L	L	X	L	H	Odd-Byte	Even-Byte
Word Write Access (16 bits)	H	L	L	X	H	L	Odd-Byte	Even-Byte
Odd Byte Read Only (8 bits)	H	L	H	X	L	H	Odd-Byte	High Z
Odd Byte Write Only (8 bits)	H	L	H	X	H	L	Odd-Byte	Don't Care

# CompactFlash Memory Card Product Manual

## 4.7 True IDE Mode I/O Transfer Function

### 4.7.1 True IDE Mode I/O Function

The CompactFlash Memory Card can be configured in a True IDE Mode of operation. This CompactFlash Card is configured in this mode only when the -OE input signal is grounded by the host. In this True IDE Mode, the PCMCIA protocol and configuration are disabled and only I/O operations to the Task File and Data Register are allowed. In this mode, no Memory or Attribute Registers are accessible to the host. CompactFlash Cards permit 8 bit data accesses if the user issues a Set Feature Command to put the device in 8 bit Mode.

Note: Removing and reinserting the CompactFlash Memory Card while the host computer's power is on will reconfigure the CompactFlash Card to PC Card ATA mode from the original True IDE Mode. To configure the CompactFlash Card in True IDE Mode, the 50-pin socket must be power cycled with the CompactFlash Card inserted and -OE (output enable) grounded by the host.

The following table defines the function of the operations for the True IDE Mode.

Table 4-17 IDE Mode I/O Function

Function Code	-CE2	-CE1	A0	-IORD	-IOWR	D15-D8	D7-D0
Invalid Mode	L	L	X	X	X	High Z	High Z
Standby Mode	H	H	X	X	X	High Z	High Z
Task File Write	H	L	1-7h	H	L	Don't Care	Data In
Task File Read	H	L	1-7h	L	H	High Z	Data Out
Data Register Write	H	L	0	H	L	Odd-Byte In	Even-Byte In
Data Register Read	H	L	0	L	H	Odd-Byte Out	Even-Byte Out
Control Register Write	L	H	6h	H	L	Don't Care	Control In
Alt Status Read	L	H	6h	L	H	High Z	Status Out

## **5.0 ATA Drive Register Set Definition and Protocol**

The CompactFlash Memory Card can be configured as a high performance I/O device through:

- a.) Standard PC-AT disk I/O address spaces 1F0h-1F7h, 3F6h-3F7h (primary); 170h-177h, 376h-377h (secondary) with IRQ 14 (or other available IRQ).
- b.) Any system decoded 16 byte I/O block using any available IRQ.
- c.) Memory space.

The communication to or from the CompactFlash Memory Card is done using the Task File registers which provide all the necessary registers for control and status information. The PCMCIA interface connects peripherals to the host using four register mapping methods. The following is a detailed description of these methods:

**Table 5-1 I/O Configurations**

<b>Standard Configurations</b>				
<b>Config Index</b>	<b>IO or Memory</b>	<b>Address</b>	<b>Drive #</b>	<b>Description</b>
0	Memory	0-F, 400-7FF	0	Memory Mapped
1	I/O	XX0-XXF	0	I/O Mapped 16 Contiguous Registers
2	I/O	1F0-1F7, 3F6-3F7	0	Primary I/O Mapped Drive 0
2	I/O	1F0-1F7, 3F6-3F7	1	Primary I/O Mapped Drive 1
3	I/O	170-177, 376-377	0	Secondary I/O Mapped Drive 0
3	I/O	170-177, 376-377	1	Secondary I/O Mapped Drive 1

## CompactFlash Memory Card Product Manual

### 5.1 I/O Primary and Secondary Address Configurations

Table 5-2 Primary and Secondary I/O Decoding

-REG	A9-A4	A3	A2	A1	A0	-IORD=0	-IOWR=0	Note
0	1F(17)	0	0	0	0	Even RD Data	Even WR Data	1, 2
0	1F(17)	0	0	0	1	Error Register	Features	1
0	1F(17)	0	0	1	0	Sector Count	Sector Count	
0	1F(17)	0	0	1	1	Sector No.	Sector No.	
0	1F(17)	0	1	0	0	Cylinder Low	Cylinder Low	
0	1F(17)	0	1	0	1	Cylinder High	Cylinder High	
0	1F(17)	0	1	1	0	Select Card/Head	Select Card/Head	
0	1F(17)	0	1	1	1	Status	Command	
0	3F(37)	0	1	1	0	Alt Status	Device Control	
0	3F(37)	0	1	1	1	Drive Address	Reserved	

Notes: 1. Register 0 is accessed with -CE1 low and -CE2 low (and A0 = Don't Care) as a word register on the combined Odd Data Bus and Even Data Bus (D15-D0). This register may also be accessed by a pair of byte accesses to the offset 0 with -CE1 low and -CE2 high. Note that the address space of this word register overlaps the address space of the Error and Feature byte-wide registers which lie at offset 1. When accessed twice as byte register with -CE1 low, the first byte to be accessed is the even byte of the word and the second byte accessed is the odd byte of the equivalent word access.

2. A byte access to register 0 with -CE1 high and -CE2 low accesses the error (read) or feature (write) register.

## 5.2 Contiguous I/O Mapped Addressing

When the system decodes a contiguous block of I/O registers to select the CompactFlash Memory Card, the registers are accessed in the block of I/O space decoded by the system as follows:

**Table 5-3 Contiguous I/O Decoding**

-REG	A3	A2	A1	A0	Offset	-IORD=0	-IOWR=0	Notes
0	0	0	0	0	0	Even RD Data	Even WR Data	1
0	0	0	0	1	1	Error	Features	2
0	0	0	1	0	2	Sector Count	Sector Count	
0	0	0	1	1	3	Sector No.	Sector No.	
0	0	1	0	0	4	Cylinder Low	Cylinder Low	
0	0	1	0	1	5	Cylinder High	Cylinder High	
0	0	1	1	0	6	Select Card /Head	Select Card/Head	
0	0	1	1	1	7	Status	Command	
0	1	0	0	0	8	Dup Even RD Data	Dup. Even WR Data	2
0	1	0	0	1	9	Dup. Odd RD Data	Dup. Odd WR Data	2
0	1	1	0	1	D	Dup. Error	Dup. Features	2
0	1	1	1	0	E	Alt Status	Device Ctl	
0	1	1	1	1	F	Drive Address	Reserved	

Notes: 1. Register 0 is accessed with -CE1 low and -CE2 low (and A0 = Don't Care) as a word register on the combined Odd Data Bus and Even Data Bus (D15-D0). This register may also be accessed by a pair of byte accesses to the offset 0 with -CE1 low and -CE2 high. Note that the address space of this word register overlaps the address space of the Error and Feature byte-wide registers that lie at offset 1. When accessed twice as byte register with -CE1 low, the first byte to be accessed is the even byte of the word and the second byte accessed is the odd byte of the equivalent word access. A byte access to register 0 with -CE1 high and -CE2 low accesses the error (read) or feature (write) register.

2. Registers at offset 8, 9 and D are non-overlapping duplicates of the registers at offset 0 and 1. Register 8 is equivalent to register 0, while register 9 accesses the odd byte. Therefore, if the registers are byte accessed in the order 9 then 8 the data will be transferred odd byte then even byte. Repeated byte accesses to register 8 or 0 will access consecutive (even then odd) bytes from the data buffer. Repeated word accesses to register 8, 9 or 0 will access consecutive words from the data buffer. Repeated byte accesses to register 9 are not supported. However, repeated alternating byte accesses to registers 8 then 9 will access consecutive (even then odd) bytes from the data buffer. Byte accesses to register 9 access only the odd byte of the data.

3. Address lines which are not indicated are ignored by the CompactFlash Memory Card for accessing all the registers in this table.

# CompactFlash Memory Card Product Manual

## 5.3 Memory Mapped Addressing

When the CompactFlash Memory Card registers appear in the common memory space window: are accessed via memory references, the registers 0-2K bytes as follows:

**Table 5-4 Memory Mapped Decoding**

-REG	A10	A9-A4	A3	A2	A1	A0	Offset	-OE=0	-WE=0	Notes
1	0	X	0	0	0	0	0	Even RD Data	Even WR Data	1
1	0	X	0	0	0	1	1	Error	Features	2
1	0	X	0	0	1	0	2	Sector Count	Sector Count	
1	0	X	0	0	1	1	3	Sector No.	Sector No.	
1	0	X	0	1	0	0	4	Cylinder Low	Cylinder Low	
1	0	X	0	1	0	1	5	Cylinder High	Cylinder High	
1	0	X	0	1	1	0	6	Select Card /Head	Select Card/Head	
1	0	X	0	1	1	1	7	Status	Command	
1	0	X	1	0	0	0	8	Dup. Even RD Data	Dup. Even WR Data	2
1	0	X	1	0	0	1	9	Dup. Odd RD Data	Dup. Odd WR Data	2
1	0	X	1	1	0	1	D	Dup. Error	Dup. Features	2
1	0	X	1	1	1	0	E	Alt Status	Device Ctl	
1	0	X	1	1	1	1	F	Drive Address	Reserved	
1	1	X	X	X	X	0	8	Even RD Data	Even WR Data	3
1	1	X	X	X	X	1	9	Odd RD Data	Odd WR Data	3

Notes: 1. Register 0 is accessed with -CE1 low and -CE2 low as a word register on the combined Odd Data Bus and Even Data Bus (D15-D0). This register may also be accessed by a pair of byte accesses to the offset 0 with -CE1 low and -CE2 high. Note that the address space of this word register overlaps the address space of the Error and Feature byte-wide registers that lie at offset 1. When accessed twice as byte register with -CE1 low, the first byte to be accessed is the even byte of the word and the second byte accessed is the odd byte of the equivalent word access.  
A byte access to address 0 with -CE1 high and -CE2 low accesses the error (read) or feature (write) register.

2. Registers at offset 8, 9 and D are non-overlapping duplicates of the registers at offset 0 and 1. Register 8 is equivalent to register 0, while register 9 accesses the odd byte. Therefore, if the registers are byte accessed in the order 9 then 8 the data will be transferred odd byte then even byte. Repeated byte accesses to register 8 or 0 will access consecutive (even then odd) bytes from the data buffer. Repeated word accesses to register 8, 9 or 0 will access consecutive words from the data buffer. Repeated byte accesses to register 9 are not supported. However, repeated alternating byte accesses to registers 8 then 9 will access consecutive (even then odd) bytes from the data buffer. Byte accesses to register 9 access only the odd byte of the data.

3. Accesses to even addresses between 400h and 7FFh access register 8. Accesses to odd addresses between 400h and 7FFh access register 9. This 1 Kbyte memory window to the data register is provided so that hosts can perform memory to memory block moves to the data register when the register lies in memory space.

Some hosts, such as the X86 processors, must increment both the source and destination addresses when executing the memory to memory block move instruction. Some PCMCIA socket adapters also have auto incrementing address logic embedded within them. This address window allows these hosts and adapters to function efficiently.

Note that this entire window accesses the Data Register FIFO and does not allow random access to the data buffer within the CompactFlash Memory Card.



### 5.4 True IDE Mode Addressing

When the CompactFlash Memory Card is configured in the True IDE Mode the I/O decoding is as follows:

**Table 5-5 True IDE Mode I/O Decoding**

<b>-CE2</b>	<b>-CE1</b>	<b>A2</b>	<b>A1</b>	<b>A0</b>	<b>-IORD=0</b>	<b>-IOWR=0</b>	<b>Note</b>
1	0	0	0	0	Even RD Data	Even WR Data	
1	0	0	0	1	Error Register	Features	
1	0	0	1	0	Sector Count	Sector Count	
1	0	0	1	1	Sector No.	Sector No.	
1	0	1	0	0	Cylinder Low	Cylinder Low	
1	0	1	0	1	Cylinder High	Cylinder High	
1	0	1	1	0	Select Card/Head	Select Card/Head	
1	0	1	1	1	Status	Command	
0	1	1	1	0	Alt Status	Device Control	
0	1	1	1	1	Drive Address	Reserved	

## CompactFlash Memory Card Product Manual

### 5.5 ATA Registers

Note: In accordance with the PCMCIA specification: each of the registers below which is located at an odd offset address may be accessed at its normal address and also the corresponding even address (normal address -1) using data bus lines (D15-D8) when -CE1 is high and -CE2 is low unless -IOIS16 is high (not asserted) and an I/O cycle is being performed.

The table below describes the combinations of data register access and is provided to assist in understanding the overlapped Data Register and Error/Feature Register rather than to attempt to define general PCMCIA word and byte access modes and operations. See the PCMCIA PC Card Standard Release 2.0 for definitions of the Card Accessing Modes for I/O and Memory cycles.

#### 5.5.1 Data Register (Address - 1F0[170];Offset 0,8,9)

The Data Register is a 16 bit register, and it is used to transfer data blocks between the CompactFlash Memory Card data buffer and the Host. This register overlaps the Error Register.

Note that because of the overlapped registers, access to the 1F1, 171 or offset 1 are not defined for word (-CE2 = 0 and -CE1 = 0) operations. SanDisk products treat these accesses as accesses to the Word Data Register. The duplicated registers at offsets 8, 9 and Dh have no restrictions on the operations that can be performed by the socket.

Data Register	CE2-	CE1-	A0	Offset	Data Bus
Word Data Register	0	0	X	0,8,9	D15-D0
Even Data Register	1	0	0	0,8	D7-D0
Odd Data Register	1	0	1	9	D7-D0
Odd Data Register	0	1	X	8,9	D15-D8
Error / Feature Register	1	0	1	1, Dh	D7-D0
Error / Feature Register	0	1	X	1	D15-D8
Error / Feature Register	0	0	X	Dh	D15-D8

---

## 5.5.2 Error Register (Address - 1F1[171]; Offset 1, 0Dh Read Only)

This register contains additional information indicated in bit 0 of the Status register. The bits about the source of an error when an error is are defined as follows:

D7	D6	D5	D4	D3	D2	D1	D0
BBK	UNC	0	IDNF	0	ABRT	0	AMNF

This register is also accessed on data bits D15-D8 during a write operation to offset 0 with -CE2 low and -CE1 high.

- Bit 7 (BBK)** This bit is set when a Bad Block is detected.
- Bit 6 (UNC)** This bit is set when an Uncorrectable Error is encountered.
- Bit 5** This bit is 0.
- Bit 4 (IDNF)** The requested sector ID is in error or cannot be found.
- Bit 3** This bit is 0.
- Bit 2 (Abort)** This bit is set if the command has been aborted because of a CompactFlash Memory Card status condition: (Not Ready, Write Fault, etc.) or when an invalid command has been issued.
- Bit 1** This bit is 0.
- Bit 0 (AMNF)** This bit is set in case of a general error.

---

## 5.5.3 Feature Register (Address - 1F1[171]; Offset 1, 0Dh Write Only)

This register provides information regarding features of the CompactFlash Memory Card that the host can utilize. This register is also accessed on data bits D15-D8 during a write operation to Offset 0 with -CE2 low and -CE1 high.

---

## 5.5.5 Sector Number (LBA 7-0) Register (Address - 1F3[173]; Offset 3)

This register contains the starting sector number or bits 7-0 of the Logical Block Address (LBA) for any CompactFlash Memory Card data access for the subsequent command.

---

## 5.5.4 Sector Count Register (Address - 1F2[172]; Offset 2)

This register contains the number of sectors of data requested to be transferred on a read or write operation between the host and the CompactFlash Memory Card. If the value in this register is zero, a count of 256 sectors is specified. If the command was successful, this register is zero at command completion. If not successfully completed, the register contains the number of sectors that need to be transferred in order to complete the request.

---

## 5.5.6 Cylinder Low (LBA 15-8) Register (Address - 1F4[174]; Offset 4)

This register contains the low order 8 bits of the starting cylinder address or bits 15-8 of the Logical Block Address.

---

## 5.5.7 Cylinder High (LBA 23-16) Register (Address - 1F5[175]; Offset 5)

This register contains the high order bits of the starting cylinder address or bits 23-16 of the Logical Block Address.

## CompactFlash Memory Card Product Manual

### 5.5.8 Drive/Head (LBA 27-24) Register (Address 1F6[176]; Offset 6)

The Drive/Head register is used to select the drive and head. It is also used to select LBA addressing instead of cylinder/head/sector addressing. The bits are defined as follows:

D7	D6	D5	D4	D3	D2	D1	D0
1	LBA	1	DRV	HS3	HS2	HS1	HS0

**Bit 7** This bit is set to 1.

**Bit 6** LBA is a flag to select either Cylinder/Head/Sector (CHS) or Logical Block Address Mode (LBA). When LBA=0, Cylinder/Head/Sector mode is selected. When LBA=1, Logical Block Address is selected. In Logical Block Mode, the Logical Block Address is interpreted as follows:  
LBA07-LBA00: Sector Number Register D7-D0.  
LBA15-LBA08: Cylinder Low Register D7-D0.  
LBA23-LBA16: Cylinder High Register D7-D0.  
LBA27-LBA24: Drive/Head Register bits HS3-HS0.

**Bit 5** This bit is set to 1.

**Bit 4 (DRV)** This bit will have the following meaning. DRV is the drive number. When DRV=0, drive (card) 0 is selected. When DRV=1, drive (card) 1 is selected. The CompactFlash Card is set to be Card 0 or 1 using the copy field of the PCMCIA Socket & Copy configuration register.

**Bit 3 (HS3)** When operating in the Cylinder, Head, Sector mode, this is bit 3 of the head number. It is Bit 27 in the Logical Block Address mode.

**Bit 2 (HS2)** When operating in the Cylinder, Head, Sector mode, this is bit 2 of the head number. It is Bit 26 in the Logical Block Address mode.

**Bit 1 (HS1)** When operating in the Cylinder, Head, Sector mode, this is bit 1 of the head number. It is Bit 25 in the Logical Block Address mode.

**Bit 0 (HS0)** When operating in the Cylinder, Head, Sector mode, this is bit 0 of the head number. It is Bit 24 in the Logical Block Address mode.

---

## 5.5.9 Status & Alternate Status Registers (Address 1F7[177]&3F6[376]; Offsets 7 & Eh)

These registers return the CompactFlash Memory Card status when read by the host. Reading the Status register does clear a pending interrupt while reading the Auxiliary Status register does not. The meaning of the status bits are described as follows:

D7	D6	D5	D4	D3	D2	D1	D0
BUSY	RDY	DWF	DSC	DRQ	CORR	0	ERR

- Bit 7 (BUSY)** The busy bit is set when the CompactFlash Memory Card has access to the command buffer and registers and the host is locked out from accessing the command register and buffer. No other bits in this register are valid when this bit is set to a 1.
- Bit 6 (RDY)** RDY indicates whether the device is capable of performing CompactFlash Memory Card operations. This bit is cleared at power up and remains cleared until the CompactFlash Card is ready to accept a command.
- Bit 5 (DWF)** This bit, if set, indicates a write fault has occurred.
- Bit 4 (DSC)** This bit is set when the CompactFlash Memory Card is ready.
- Bit 3 (DRQ)** The Data Request is set when the CompactFlash Memory Card requires that information be transferred either to or from the host through the Data register.
- Bit 2 (CORR)** This bit is set when a Correctable data error has been encountered and the data has been corrected. This condition does not terminate a multi-sector read operation.
- Bit 1 (IDX)** This bit is always set to 0.
- Bit 0 (ERR)** This bit is set when the previous command has ended in some type of error. The bits in the Error register contain additional information describing the error.

---

## 5.5.10 Device Control Register (Address - 3F6[376]; Offset Eh)

This register is used to control the CompactFlash Memory Card interrupt request and to issue an ATA soft reset to the card. The bits are defined as follows:

D7	D6	D5	D4	D3	D2	D1	D0
X	X	X	X	1	SW Rst	-IEn	0

- Bit 7** This bit is an X (don't care).
- Bit 6** This bit is an X (don't care).
- Bit 5** This bit is an X (don't care).
- Bit 4** This bit is an X (don't care).
- Bit 3** This bit is ignored by the CompactFlash Memory Card.
- Bit 2 (SW Rst)** This bit is set to 1 in order to force the CompactFlash Memory Card to perform an AT Disk controller Soft Reset operation. This does not change the PCMCIA Card Configuration Registers (4.3.2 to 4.3.5) as a hardware Reset does. The Card remains in Reset until this bit is reset to '0'.
- Bit 1 (-IEn)** The Interrupt Enable bit enables interrupts when the bit is 0. When the bit is 1, interrupts from the CompactFlash Memory Card are disabled. This bit also controls the Int bit in the Configuration and Status Register. This bit is set to 0 at power on and Reset.
- Bit 0** This bit is ignored by the CompactFlash Memory Card.

## CompactFlash Memory Card Product Manual

### 5.5.11 Card (Drive) Address Register (Address 3F7[377]; Offset Fh)

This register is provided for compatibility with the AT disk drive interface. It is recommended that this register not be mapped into the host's I/O space because of potential conflicts on Bit 7. The bits are defined as follows:

D7	D6	D5	D4	D3	D2	D1	D0
X	-WTG	-HS3	-HS2	-HS1	-HS0	-nDS1	-nDS0

- Bit 7** This bit is unknown.  
Implementation Note:  
Conflicts may occur on the host data bus when this bit is provided by a Floppy Disk Controller operating at the same addresses as the CompactFlash Memory Card. Following are some possible solutions to this problem for the PCMCIA implementation:
1. Locate the CompactFlash Memory Card at a non-conflicting address, i.e. Secondary address (377) or in an independently decoded Address Space when a Floppy Disk Controller is located at the Primary addresses.
  2. Do not install a Floppy and a CompactFlash Memory Card in the system at the same time.
  3. Implement a socket adapter which can be programmed to (conditionally) tri-state D7 of I/O address 3F7/377 when a CompactFlash Memory Card is installed and conversely to tri-state D6-D0 of I/O address 3F7/377 when a floppy controller is installed.
  4. Do not use the CompactFlash Memory Card's Drive Address register. This may be accomplished by either a) If possible, program the host adapter to enable only I/O addresses 1F0-1F7, 3F6 (or 170-177, 176) to the CompactFlash Memory Card or b) if provided use an additional Primary / Secondary configuration in the CompactFlash Card which does not respond to accesses to I/O locations 3F7 and 377. With either of these implementations, the host software must not attempt to use information in the Drive Address Register.
- Bit 6 (-WTG)** This bit is 0 when a write operation is in progress, otherwise, it is 1.
- Bit 5 (-HS3)** This bit is the negation of bit 3 in the Drive/Head register.
- Bit 4 (-HS2)** This bit is the negation of bit 2 in the Drive/Head register.
- Bit 3 (-HS1)** This bit is the negation of bit 1 in the Drive/Head register.
- Bit 2 (-HS0)** This bit is the negation of bit 0 in the Drive/Head register.
- Bit 1 (-nDS1)** This bit is 0 when drive 1 is active and selected.
- Bit 0 (-nDS0)** This bit is 0 when the drive 0 is active and selected.

## **6.0 ATA Command Description**

This section defines the software requirements and the format of the commands the host sends to the CompactFlash Memory Cards. Commands are issued to the CompactFlash Card by loading the required registers in the command block with the supplied parameters, and then writing the command code to the Command Register. The manner in which a command is accepted varies. There are three classes (see Table 6-1) of command acceptance, all dependent on the host not issuing commands unless the CompactFlash Card is not busy. (The BUSY bit in the status and alternate status registers is 0.)

- Upon receipt of a Class 1 command, the CompactFlash Card sets the BUSY bit within 400 nsec.

- Upon receipt of a Class 2 command, the CompactFlash Memory Card sets the BUSY bit within 400 nsec, sets up the sector buffer for a write operation, sets DRQ within 700  $\mu$ sec, and clears the BUSY bit within 400 nsec of setting DRQ.
- Upon receipt of a Class 3 command, the CompactFlash Memory Card sets the BUSY bit within 400 nsec, sets up the sector buffer for a write operation, sets DRQ within 20 msec (assuming no re-assignments), and clears the BUSY bit within 400 nsec of setting DRQ.

---

### **6.1 ATA Command Set**

Table 6-1 summarizes the ATA command set with the paragraphs that follow describing the individual commands and the task file for each.

# CompactFlash Memory Card Product Manual

**Table 6-1 ATA Command Set**

Class	COMMAND	Code	FR	SC	SN	CY	DH	LBA
1	Check Power Mode	E5h or 98h	-	-	-	-	D	-
1	Execute Drive Diagnostic	90h	-	-	-	-	D	-
1	Erase Sector(s) (Note 2)	C0h	-	Y	Y	Y	Y	Y
2	Format Track	50h	-	Y	-	Y	Y	Y
1	Identify Drive	ECh	-	-	-	-	D	-
1	Idle	E3h or 97h	-	Y	-	-	D	-
1	Idle Immediate	E1h or 95h	-	-	-	-	D	-
1	Initialize Drive Parameters	91h	-	Y	-	-	Y	-
1	Read Buffer	E4h	-	-	-	-	D	-
1	Read Multiple	C4h	-	Y	Y	Y	Y	Y
1	Read Long Sector	22h or 23h	-	-	Y	Y	Y	Y
1	Read Sector(s)	20h or 21h	-	Y	Y	Y	Y	Y
1	Read Verify Sector(s)	40h or 41h	-	Y	Y	Y	Y	Y
1	Recalibrate	1Xh	-	-	-	-	D	-
1	Request Sense (Note 1)	03h	-	-	-	-	D	-
1	Seek	7Xh	-	-	Y	Y	Y	Y
1	Set Features	EFh	Y	-	-	-	D	-
1	Set Multiple Mode	C6h	-	Y	-	-	D	-
1	Set Sleep Mode	E6h or 99h	-	-	-	-	D	-
1	Stand By	E2h or 96h	-	-	-	-	D	-
1	Stand By Immediate	E0h or 94h	-	-	-	-	D	-
1	Translate Sector (Note 1)	87h	-	Y	Y	Y	Y	Y
1	Wear Level (Note 1)	F5h	-	-	-	-	Y	-
2	Write Buffer	E8h	-	-	-	-	D	-
2	Write Long Sector	32h or 33h	-	-	Y	Y	Y	Y
3	Write Multiple	C5h	-	Y	Y	Y	Y	Y
3	Write Multiple w/o Erase (Note 2)	CDh	-	Y	Y	Y	Y	Y
2	Write Sector(s)	30h or 31h	-	Y	Y	Y	Y	Y
2	Write Sector(s) w/o Erase (Note 2)	38h	-	Y	Y	Y	Y	Y
2	Write Verify Sector(s)	3Ch	-	Y	Y	Y	Y	Y

Note 1: These commands are not standard PC Card ATA commands but provide additional functionality.

Note 2: These commands are not standard PC Card ATA commands and these features are no longer supported with the introduction of 256 Mbit Flash Technology. If one of these commands is issued, the sectors will be erased but there will be no net gain in write performance when using the Write Without Erase command.

Definitions: FR = Features Register, SC = Sector Count Register, SN = Sector Number Register, CY = Cylinder Registers, DH = Card/Drive/Head Register, LBA = Logical Block Address Mode Supported (see command descriptions for use).

Y - The register contains a valid parameter for this command. For the Drive/Head Register Y means both the CompactFlash Card and head parameters are used; D - only the CompactFlash Card parameter is valid and not the head parameter.



## CompactFlash Memory Card Product Manual

---

### 6.1.1 Check Power Mode - 98H, E5H

Bit ->	7	6	5	4	3	2	1	0
<b>Command (7)</b>	E5H or 98H							
<b>C/D/H (6)</b>	X		Drive		X			
<b>Cyl High (5)</b>	X							
<b>Cyl Low (4)</b>	X							
<b>Sec Num (3)</b>	X							
<b>Sec Cnt (2)</b>	X							
<b>Feature (1)</b>	X							

This command checks the power mode.

If the CompactFlash Memory Card is in, going to, or recovering from the sleep mode, the CompactFlash Card sets BSY, sets the Sector Count Register to 00h, clears BSY and generates an interrupt.

If the CompactFlash Memory Card is in Idle mode, the CompactFlash Card sets BSY, sets the Sector Count Register to FFh, clears BSY and generates an interrupt.

---

### 6.1.2 Execute Drive Diagnostic - 90H

Bit ->	7	6	5	4	3	2	1	0
<b>Command (7)</b>	90H							
<b>C/D/H (6)</b>	X		Drive		X			
<b>Cyl High (5)</b>	X							
<b>Cyl Low (4)</b>	X							
<b>Sec Num (3)</b>	X							
<b>Sec Cnt (2)</b>	X							
<b>Feature (1)</b>	X							

This command performs the internal diagnostic tests implemented by the CompactFlash Memory Card.

The Diagnostic codes shown in Table 6-2 are returned in the Error Register at the end of the command.

# CompactFlash Memory Card Product Manual

**Table 6-2 Diagnostic Codes**

Code	Error Type
01h	No Error Detected
02h	Formatter Device Error
03h	Sector Buffer Error
04h	ECC Circuitry Error
05h	Controlling Microprocessor Error
8Xh	Slave Failed (True IDE Mode)

## 6.1.3 Erase Sector(s) - C0H

Bit ->	7	6	5	4	3	2	1	0
<b>Command (7)</b>	C0H							
<b>C/D/H (6)</b>	1	LBA	1	Drive	Head (LBA 27-24)			
<b>Cyl High (5)</b>	Cylinder High (LBA 23-16)							
<b>Cyl Low (4)</b>	Cylinder Low (LBA 15-8)							
<b>Sec Num (3)</b>	Sector Number (LBA 7-0)							
<b>Sec Cnt (2)</b>	Sector Count							
<b>Feature (1)</b>	X							

This command is no longer recommended for use with 256 Mbit Flash technology. There is essentially no net gain in the use of the Erase Sectors Command and/or the Write Without Erase Commands. This command is supported to guarantee backward compatibility.

## CompactFlash Memory Card Product Manual

### 6.1.4 Format Track - 50H

Bit ->	7	6	5	4	3	2	1	0
<b>Command (7)</b>	50H							
<b>C/D/H (6)</b>	1	LBA	1	Drive	Head (LBA 27-24)			
<b>Cyl High (5)</b>	Cylinder High (LBA 23-16)							
<b>Cyl Low (4)</b>	Cylinder Low (LBA 15-8)							
<b>Sec Num (3)</b>	X (LBA 7-0)							
<b>Sec Cnt (2)</b>	Count (LBA mode only)							
<b>Feature (1)</b>	X							

This command writes the desired head and cylinder of the selected drive with a FFh pattern. To remain host backward compatible, the CompactFlash Memory Card expects a sector buffer of data from the host to follow the

command with the same protocol as the Write Sector(s) command although the information in the buffer is not used by the CompactFlash Card. If LBA=1 then the number of sectors to format is taken from the Sec Cnt register (0=256).

### 6.1.5 Identify Drive - ECH

Bit ->	7	6	5	4	3	2	1	0
<b>Command (7)</b>	ECH							
<b>C/D/H (6)</b>	X	X	X	Drive	X			
<b>Cyl High (5)</b>	X							
<b>Cyl Low (4)</b>	X							
<b>Sec Num (3)</b>	X							
<b>Sec Cnt (2)</b>	X							
<b>Feature (1)</b>	X							

The Identify Drive command enables the host to receive parameter information from the CompactFlash Memory Card. This command has the same protocol as the Read Sector(s) command. The parameter words in the buffer have the

arrangement and meanings defined in Table 6-3. All reserved bits or words are zero. Table 6-3 is the definition for each field in the Identify Drive Information.

## CompactFlash Memory Card Product Manual

Table 6-3 Identify Drive Information

Word Address	Default Value	Total Bytes	Data Field Type Information
0	848AH	2	General configuration bit-significant information
1	XXXX	2	Default number of cylinders
2	0000H	2	Reserved
3	XXXX	2	Default number of heads
4	0000H	2	Number of unformatted bytes per track
5	0240H	2	Number of unformatted bytes per sector
6	XXXX	2	Default number of sectors per track
7-8	XXXX	4	Number of sectors per card (Word 7 = MSW, Word 8 = LSW)
9	0000H	2	Reserved
10-19	aaaa	20	Serial number in ASCII (Right Justified)
20	0002H	2	Buffer type (dual ported)
21	0002H	2	Buffer size in 512 byte increments
22	0004H	2	# of ECC bytes passed on Read/Write Long Commands
23-26	aaaa	8	Firmware revision in ASCII (Rev M.ms) set by code Big Endian Byte Order in Word
27-46	aaaa	40	Model number in ASCII (Left Justified) Big Endian Byte Order in Word
47	0001H	2	Maximum of 1 sector on Read/Write Multiple command
48	0000H	2	Double Word not supported
49	0200H	2	Capabilities: DMA NOT Supported (bit 8), LBA supported (bit 9)
50	0000H	2	Reserved
51	0100H	2	PIO data transfer cycle timing mode 1
52	0000H	2	DMA data transfer cycle timing mode Not Supported
53	0001H	2	Translation parameters are valid
54	XXXX	2	Current numbers of cylinders
55	XXXX	2	Current numbers of heads
56	XXXX	2	Current sectors per track
57-58	XXXX	4	Current capacity in sectors (LBAs)(Word 57 = LSW, Word 58 = MSW)
59	010XH	2	Multiple sector setting is valid
60-61	XXXX	4	Total number of sectors addressable in LBA Mode
62-127	0000H	138	Reserved
128-159	0000H	64	Reserved vendor unique bytes
160-255	0000H	192	Reserved

# CompactFlash Memory Card Product Manual

---

## 6.1.5.1 General Configuration

This field informs the host that this is a non-magnetic, hard sectored, removable storage device with a transfer rate greater than 10 mb/sec and is not MFM encoded.

---

## 6.1.5.2 Default Number of Cylinders

This field contains the number of translated cylinders in the default translation mode. This value will be the same as the number of cylinders.

---

## 6.1.5.3 Default Number of Heads

This field contains the number of translated heads in the default translation mode.

---

## 6.1.5.4 Number of Unformatted Bytes per Track

This field contains the number of unformatted bytes per translated track in the default translation mode.

---

## 6.1.5.5 Number of Unformatted Bytes per Sector

This field contains the number of unformatted bytes per sector in the default translation mode.

---

## 6.1.5.6 Default Number of Sectors per Track

This field contains the number of sectors per track in the default translation mode.

---

## 6.1.5.7 Number of Sectors per Card

This field contains the number of sectors per CompactFlash Memory Card. This double word value is also the first invalid address in LBA translation mode.

---

## 6.1.5.8 Memory Card Serial Number

The contents of this field are right justified and padded with spaces (20h).

---

## 6.1.5.9 Buffer Type

This field defines the buffer capability with the 0002h meaning a dual ported multi-sector buffer capable of simultaneous data transfers to or from the host and the CompactFlash Memory Card.

---

## 6.1.5.10 Buffer Size

This field defines the buffer capacity of 2 sectors or 1 kilobyte of SRAM.

---

## 6.1.5.11 ECC Count

This field defines the number of ECC bytes used on each sector in the Read and Write Long commands.

---

## 6.1.5.12 Firmware Revision

This field contains the revision of the firmware for this product.

---

## 6.1.5.13 Model Number

This field contains the model number for this product and is left justified and padded with spaces (20h).

## **CompactFlash Memory Card Product Manual**

---

### **6.1.5.14 Read/Write Multiple Sector Count**

This field contains the maximum number of sectors that can be read or written per interrupt using the Read Multiple or Write Multiple commands.

---

### **6.1.5.15 Double Word Support**

This field indicates this product will not support double word transfers.

---

### **6.1.5.16 Capabilities**

This field indicates this product will not support DMA Data transfers but does support LBA mode.

---

### **6.1.5.17 PIO Data Transfer Cycle Timing Mode**

This field defines the mode for PIO data transfer.

---

### **6.1.5.18 DMA Data Transfer Cycle Timing Mode**

This field states this product doesn't support any DMA data transfer mode.

---

### **6.1.5.19 Translation Parameters Valid**

This field contains the value 0001h indicating that words 54 to 58 are valid and reflect the current number of cylinders, heads and sectors.

---

### **6.1.5.20 Current Number of Cylinders, Heads, Sectors/Track**

These fields contains the current number of user addressable Cylinders, Heads, and Sectors/Track in the current translation mode.

---

### **6.1.5.21 Current Capacity**

This field contains the product of the current cylinders times heads times sectors.

---

### **6.1.5.22 Multiple Sector Setting**

This field contains a validity flag in the odd byte and the current number of sectors that can be transferred per interrupt for R/W Multiple in the even byte. The odd byte is always 01H which indicates that the even byte is always valid.

The even byte value depends on the value set by the Set Multiple command. The even byte of this word by default contains a 00H which indicates that R/W Multiple commands are not valid. The only other value returned by the CompactFlash Memory Card in the even byte is a 01H value which indicates that 1 sector per interrupt can be transferred in R/W Multiple mode.

---

### **6.1.5.23 Total Sectors Addressable in LBA Mode**

This field contains the number of sectors addressable for the CompactFlash Memory Card in LBA mode only.

## CompactFlash Memory Card Product Manual

### 6.1.6 Idle - 97H, E3H

Bit ->	7	6	5	4	3	2	1	0
<b>Command (7)</b>	E3H or 97H							
<b>C/D/H (6)</b>	X		Drive		X			
<b>Cyl High (5)</b>	X							
<b>Cyl Low (4)</b>	X							
<b>Sec Num (3)</b>	X							
<b>Sec Cnt (2)</b>	Timer Count (5 msec increments)							
<b>Feature (1)</b>	X							

This command causes the CompactFlash Memory Card to set BSY, enter the Idle (Read) mode, clear BSY and generate an interrupt. If the sector count is non-zero, it is interpreted as a timer count with each count being 5 milliseconds and the automatic

power down mode is enabled. If the sector count is zero, the automatic power down mode is disabled. Note that this time base (5 msec) is different from the ATA specification.

### 6.1.7 Idle Immediate - 95H, E1H

Bit ->	7	6	5	4	3	2	1	0
<b>Command (7)</b>	E1H or 95H							
<b>C/D/H (6)</b>	X		Drive		X			
<b>Cyl High (5)</b>	X							
<b>Cyl Low (4)</b>	X							
<b>Sec Num (3)</b>	X							
<b>Sec Cnt (2)</b>	X							
<b>Feature (1)</b>	X							

This command causes the CompactFlash Memory Card to set BSY, enter the Idle (Read) mode, clear BSY and generate an interrupt.

## CompactFlash Memory Card Product Manual

### 6.1.8 Initialize Drive Parameters - 91H

Bit ->	7	6	5	4	3	2	1	0
Command (7)	91H							
C/D/H (6)	X	0	X	Drive	Max Head (no. of heads-1)			
Cyl High (5)					X			
Cyl Low (4)					X			
Sec Num (3)					X			
Sec Cnt (2)					Number of Sectors			
Feature (1)					X			

This command enables the host to set the number of sectors per track and the number of heads per cylinder. Only the Sector Count and the Card/Drive/Head registers are used by this command.

Note: SanDisk recommends NOT using this command in any system because DOS determines the offset to the Boot Record based on the number of heads and sectors per track. If a CompactFlash Memory Card is "Formatted" with one head and sector per track value, the same CompactFlash Card will not operate correctly with DOS configured with another heads and sectors per track value.

### 6.1.9 Read Buffer - E4H

Bit ->	7	6	5	4	3	2	1	0
Command (7)	E4H							
C/D/H (6)	X			Drive	X			
Cyl High (5)					X			
Cyl Low (4)					X			
Sec Num (3)					X			
Sec Cnt (2)					X			
Feature (1)					X			

The Read Buffer command enables the host to read the current contents of the CompactFlash Memory Card's sector buffer. This command has the same protocol as the Read Sector(s) command.



## 6.1.10 Read Multiple - C4H

Bit ->	7	6	5	4	3	2	1	0
<b>Command (7)</b>	C4H							
<b>C/D/H (6)</b>	1	LBA	1	Drive	Head (LBA 27-24)			
<b>Cyl High (5)</b>	Cylinder High (LBA 23-16)							
<b>Cyl Low (4)</b>	Cylinder Low (LBA 15-8)							
<b>Sec Num (3)</b>	Sector Number (LBA 7-0)							
<b>Sec Cnt (2)</b>	Sector Count							
<b>Feature (1)</b>	X							

**Note:** The current revision of the CompactFlash Memory Card only supports a block count of 1 as indicated in the Identify Drive Information command. This command is provided for compatibility with future products which may support a larger block count.

The Read Multiple command performs similarly to the Read Sectors command. Interrupts are not generated on every sector, but on the transfer of a block which contains the number of sectors defined by a Set Multiple command.

Command execution is identical to the Read Sectors operation except that the number of sectors defined by a Set Multiple command is transferred without intervening interrupts. DRQ qualification of the transfer is required only at the start of the data block, not on each sector.

The block count of sectors to be transferred without intervening interrupts is programmed by the Set Multiple Mode command, which must be executed prior to the Read Multiple command. When the Read Multiple command is issued, the Sector Count Register contains the number of sectors (not the number of blocks or the block count) requested. If the number of requested sectors is not evenly divisible by the block count, as many full blocks as possible are transferred, followed by a final, partial block transfer. The partial block transfer is for  $n$  sectors, where

$$n = (\text{sector count}) - \text{modulo}(\text{block count}).$$

If the Read Multiple command is attempted before the Set Multiple Mode command has been executed or when Read Multiple commands are

disabled, the Read Multiple operation is rejected with an Aborted Command error. Disk errors encountered during Read Multiple commands are posted at the beginning of the block or partial block transfer, but DRQ is still set and the data transfer will take place as it normally would, including transfer of corrupted data, if any.

Interrupts are generated when DRQ is set at the beginning of each block or partial block. The error reporting is the same as that on a Read Sector(s) Command. This command reads from 1 to 256 sectors as specified in the Sector Count register. A sector count of 0 requests 256 sectors. The transfer begins at the sector specified in the Sector Number Register.

At command completion, the Command Block Registers contain the cylinder, head and sector number of the last sector read.

If an error occurs, the read terminates at the sector where the error occurred. The Command Block Registers contain the cylinder, head and sector number of the sector where the error occurred. The flawed data is pending in the sector buffer.

Subsequent blocks or partial blocks are transferred only if the error was a correctable data error. All other errors cause the command to stop after transfer of the block which contained the error.

## CompactFlash Memory Card Product Manual

### 6.1.11 Read Long Sector - 22H, 23H

Bit ->	7	6	5	4	3	2	1	0
Command (7)	22H or 23H							
C/D/H (6)	1	LBA	1	Drive	Head (LBA 27-24)			
Cyl High (5)	Cylinder High (LBA 23-16)							
Cyl Low (4)	Cylinder Low (LBA 15-8)							
Sec Num (3)	Sector Number (LBA 7-0)							
Sec Cnt (2)	X							
Feature (1)	X							

The Read Long command performs similarly to the Read Sector(s) command except that it returns 516 bytes of data instead of 512 bytes. During a Read Long command, the CompactFlash Memory Card does not check the ECC bytes to determine if there has been a data error. Only single sector read long operations are supported. The transfer consists of

512 bytes of data transferred in word mode followed by 4 bytes of random data transferred in byte mode. Random data is returned instead of ECC bytes because of the nature of the ECC system used. This command has the same protocol as the Read Sector(s) command.

### 6.1.12 Read Sector(s) - 20H, 21H

Bit ->	7	6	5	4	3	2	1	0
Command (7)	20H or 21H							
C/D/H (6)	1	LBA	1	Drive	Head (LBA 27-24)			
Cyl High (5)	Cylinder High (LBA 23-16)							
Cyl Low (4)	Cylinder Low (LBA 15-8)							
Sec Num (3)	Sector Number (LBA 7-0)							
Sec Cnt (2)	Sector Count							
Feature (1)	X							

This command reads from 1 to 256 sectors as specified in the Sector Count register. A sector count of 0 requests 256 sectors. The transfer begins at the sector specified in the Sector Number Register. When this command is issued and after each sector of data (except the last one) has been read by the host, the CompactFlash Memory Card sets BSY, puts the sector of data in the buffer, sets DRQ, clears BSY, and generates an interrupt. The host then reads the 512 bytes of data from the buffer.

At command completion, the Command Block Registers contain the cylinder, head and sector number of the last sector read. If an error occurs, the read terminates at the sector where the error occurred. The Command Block Registers contain the cylinder, head, and sector number of the sector where the error occurred. The flawed data is pending in the sector buffer.

## CompactFlash Memory Card Product Manual

### 6.1.13 Read Verify Sector(s) - 40H, 41H

Bit ->	7	6	5	4	3	2	1	0
<b>Command (7)</b>	40H or 41H							
<b>C/D/H (6)</b>	1	LBA	1	Drive	Head (LBA 27-24)			
<b>Cyl High (5)</b>	Cylinder High (LBA 23-16)							
<b>Cyl Low (4)</b>	Cylinder Low (LBA 15-8)							
<b>Sec Num (3)</b>	Sector Number (LBA 7-0)							
<b>Sec Cnt (2)</b>	Sector Count							
<b>Feature (1)</b>	X							

This command is identical to the Read Sectors command, except that DRQ is never set and no data is transferred to the host. When the command is accepted, the CompactFlash Memory Card sets BSY.

When the requested sectors have been verified, the CompactFlash Memory Card clears BSY and generates an interrupt. Upon command completion, the Command Block Registers contain the

cylinder, head, and sector number of the last sector verified.

If an error occurs, the verify terminates at the sector where the error occurs. The Command Block Registers contain the cylinder, head and sector number of the sector where the error occurred. The Sector Count Register contains the number of sectors not yet verified.

### 6.1.14 Recalibrate - 1XH

Bit ->	7	6	5	4	3	2	1	0
<b>Command (7)</b>	1XH							
<b>C/D/H (6)</b>	1	LBA	1	Drive	X			
<b>Cyl High (5)</b>	X							
<b>Cyl Low (4)</b>	X							
<b>Sec Num (3)</b>	X							
<b>Sec Cnt (2)</b>	X							
<b>Feature (1)</b>	X							

This command is effectively a NOP command to the CompactFlash Memory Card and is provided for compatibility purposes. After this command is executed the Cyl High and Cyl Low as well as the

Head number will be 0 and Sec Num will be 1 if LBA=0 and 0 if LBA=1 (i.e. the first block in LBA is 0 while CHS mode the sector number starts at 1).

## CompactFlash Memory Card Product Manual

### 6.1.15 Request Sense - 03H

Bit ->	7	6	5	4	3	2	1	0
Command (7)	03H							
C/D/H (6)	1	X	1	Drive			X	
Cyl High (5)	X							
Cyl Low (4)	X							
Sec Num (3)	X							
Sec Cnt (2)	X							
Feature (1)	X							

This command requests an extended error code after a command ends with an error. Table 6-4 defines the valid extended error codes for the CompactFlash Memory Card Series product. The extended error code is returned to the host in the Error Register. This command must be the next command issued to the CompactFlash Card following the command which returned an error.

**Table 6-4 Extended Error Codes**

Extended Error Code	Description
00h	No Error Detected
01h	Self Test OK (No Error)
09h	Miscellaneous Error
20h	Invalid Command
21h	Invalid Address (Requested Head or Sector Invalid)
2Fh	Address Overflow (Address Too Large)
35h, 36h	Supply or generated Voltage Out of Tolerance
11h	Uncorrectable ECC Error
18h	Corrected ECC Error
05h, 30-34h, 37h, 3Eh	Self Test or Diagnostic Failed
10h, 14h	ID Not Found
3Ah	Spare Sectors Exhausted
1Fh	Data Transfer Error / Aborted Command
0Ch, 38H, 3Bh, 3Ch, 3Fh	Corrupted Media Format
03h	Write / Erase Failed

## CompactFlash Memory Card Product Manual

### 6.1.16 Seek - 7XH

Bit ->	7	6	5	4	3	2	1	0
<b>Command (7)</b>	7XH							
<b>C/D/H (6)</b>	1	LBA	1	Drive	Head (LBA 27-24)			
<b>Cyl High (5)</b>	Cylinder High (LBA 23-16)							
<b>Cyl Low (4)</b>	Cylinder Low (LBA 15-8)							
<b>Sec Num (3)</b>	X (LBA 7-0)							
<b>Sec Cnt (2)</b>	X							
<b>Feature (1)</b>	X							

This command is effectively a NOP command to the CompactFlash Memory Card although it does perform a range check of cylinder and head or LBA address and returns an error if the address is out of range.

### 6.1.17 Set Features - EFH

Bit ->	7	6	5	4	3	2	1	0
<b>Command (7)</b>	EFH							
<b>C/D/H (6)</b>	X		Drive		X			
<b>Cyl High (5)</b>	X							
<b>Cyl Low (4)</b>	X							
<b>Sec Num (3)</b>	X							
<b>Sec Cnt (2)</b>	Config							
<b>Feature (1)</b>	Feature							

This command is used by the host to establish or select certain features. Table 6-5 defines all features that are supported. Please note that the 9AH feature is unique to the CompactFlash Memory Card and are not part of the ATA Specification.

## CompactFlash Memory Card Product Manual

**Table 6-5 Features Supported**

Feature	Operation
01H	Enable 8 bit data transfer.
55H	Disable Read Look Ahead.
66H	Disable Power on Reset (POR) establishment of defaults at Soft Reset.
69H	Accepted for backward compatibility with the SDP Series but has no impact on the CF Memory Card.
81H	Disable 8 bit data transfer.
96H	Accepted for backward compatibility with the SDP Series but has no impact on the CF Memory Card.
9AH	Accepted for backward compatibility with the SDP Series but has no impact on the CF Memory Card.
BBH	4 bytes of data apply on Read/Write Long commands.
CCH	Enable Power on Reset (POR) establishment of defaults at Soft Reset.

Features 01H and 81H are used to enable and clear 8 bit data transfer mode. If the 01H feature command is issued, all data transfers will occur on the low order D7-D0 data bus and the IOIS16 signal will not be asserted for data register accesses.

Features 55H and BBH are the default features for the CompactFlash Memory Card; thus, the host does not have to issue this command with these features unless it is necessary for compatibility reasons.

The 9AH Feature is accepted for backward compatibility with the SDP Series but has no impact on the CompactFlash Memory Card. SanDisk does not recommend the use of this command in new designs.

Features 66H and CCH can be used to enable and disable whether the Power On Reset (POR) Defaults will be set when a soft reset occurs. The default setting is to revert to the POR defaults when a soft reset occurs. POR defaults the number of heads and sectors along with 16 bit data transfers and the read/write multiple block count.

## 6.1.18 Set Multiple Mode - C6H

Bit ->	7	6	5	4	3	2	1	0
<b>Command (7)</b>	C6H							
<b>C/D/H (6)</b>	X		Drive		X			
<b>Cyl High (5)</b>	X							
<b>Cyl Low (4)</b>	X							
<b>Sec Num (3)</b>	X							
<b>Sec Cnt (2)</b>	Sector Count							
<b>Feature (1)</b>	X							

This command enables the CompactFlash Card to perform Read and Write Multiple operations and establishes the block count for these commands. The Sector Count Register is loaded with the number of sectors per block. The current version of the CompactFlash Card supports only a block size of 1 sector per block. Future versions may support larger block sizes. Upon receipt of the command, the CompactFlash Card sets BSY to 1 and checks the Sector Count Register.

loaded for all subsequent Read Multiple and Write Multiple commands and execution of those commands is enabled. If a block count is not supported, an Aborted Command error is posted, and Read Multiple and Write Multiple commands are disabled. If the Sector Count Register contains 0 when the command is issued, Read and Write Multiple commands are disabled. At power on, or after a hardware or (unless disabled by a Set Feature command) software reset, the default mode is Read and Write Multiple disabled.

If the Sector Count Register contains a valid value and the block count is supported, the value is

## 6.1.19 Set Sleep Mode- 99H, E6H

Bit ->	7	6	5	4	3	2	1	0
<b>Command (7)</b>	E6H or 99H							
<b>C/D/H (6)</b>	X		Drive		X			
<b>Cyl High (5)</b>	X							
<b>Cyl Low (4)</b>	X							
<b>Sec Num (3)</b>	X							
<b>Sec Cnt (2)</b>	X							
<b>Feature (1)</b>	X							

This command causes the CompactFlash Memory Card to set BSY, enter the Sleep mode, clear BSY and generate an interrupt. Recovery from sleep mode is accomplished by simply issuing another command (a reset is permitted but not required). Sleep mode is also entered when internal timers

expire so the host does not need to issue this command except when it wishes to enter Sleep mode immediately. The default value for the read to sleep timer is 5 milliseconds. Note that this time base (5 msec) is different from the ATA Specification.

## CompactFlash Memory Card Product Manual

### 6.1.20 Standby - 96H, E2H

Bit ->	7	6	5	4	3	2	1	0
Command (7)	E2H or 96H							
C/D/H (6)	X		Drive		X			
Cyl High (5)					X			
Cyl Low (4)					X			
Sec Num (3)					X			
Sec Cnt (2)					X			
Feature (1)					X			

This command causes the CompactFlash Memory Card to set BSY, enter the Sleep mode (which corresponds to the ATA "Standby" Mode), clear BSY and return the interrupt immediately.

Recovery from sleep mode is accomplished by simply issuing another command (a reset is not required).

### 6.1.21 Standby Immediate - 94H, E0H

Bit ->	7	6	5	4	3	2	1	0
Command (7)	E0H or 94H							
C/D/H (6)	X		Drive		X			
Cyl High (5)					X			
Cyl Low (4)					X			
Sec Num (3)					X			
Sec Cnt (2)					X			
Feature (1)					X			

This command causes the CompactFlash Memory Card to set BSY, enter the Sleep mode (which corresponds to the ATA "Standby" Mode), clear BSY and return the interrupt immediately.

Recovery from sleep mode is accomplished by simply issuing another command (a reset is not required).



# CompactFlash Memory Card Product Manual

## 6.1.22 Translate Sector - 87H

Bit ->	7	6	5	4	3	2	1	0
<b>Command (7)</b>	87H							
<b>C/D/H (6)</b>	1	LBA	1	Drive	Head (LBA 27-24)			
<b>Cyl High (5)</b>	Cylinder High (LBA 23-16)							
<b>Cyl Low (4)</b>	Cylinder Low (LBA 15-8)							
<b>Sec Num (3)</b>	Sector Number (LBA 7-0)							
<b>Sec Cnt (2)</b>	X							
<b>Feature (1)</b>	X							

When this command is issued, the controller responds with a 512 byte buffer of information on the desired cylinder, head and sector with the actual Logical Address. Table 6-6 represents the information in the buffer. Please note that this command is unique to the SanDisk CompactFlash Memory Card.

**Table 6-6 Translate Sector Information**

Address	Information
00h-01h	Cylinder MSB (00), Cylinder LSB (01)
02h	Head
03h	Sector
04h-06h	LBA MSB (04) - LSB (06)
07h-12h	Reserved
13h	Erased Flag (FFh) = Erased 00h = Not Erased
14h - 17h	Reserved
18h-1Ah	Reserved
1Bh-1FFh	Reserved

## CompactFlash Memory Card Product Manual

### 6.1.23 Wear Level - F5H

Bit ->	7	6	5	4	3	2	1	0
Command (7)	F5H							
C/D/H (6)	X	X	X	Drive	Flag			
Cyl High (5)					X			
Cyl Low (4)					X			
Sec Num (3)					X			
Sec Cnt (2)	Completion Status							
Feature (1)					X			

This command is effectively a NOP command and only implemented for backward compatibility with earlier SanDisk SDP series products. The Sector Count Register will always be returned with an 00H indicating Wear Level is not needed.

### 6.1.24 Write Buffer - E8H

Bit ->	7	6	5	4	3	2	1	0
Command (7)	E8H							
C/D/H (6)	X		Drive		X			
Cyl High (5)					X			
Cyl Low (4)					X			
Sec Num (3)					X			
Sec Cnt (2)					X			
Feature (1)					X			

The Write Buffer command enables the host to overwrite contents of the CompactFlash Memory Card's sector buffer with any data pattern desired. This command has the same protocol as the Write Sector(s) command and transfers 512 bytes.

## CompactFlash Memory Card Product Manual

### 6.1.25 Write Long Sector - 32H, 33H

Bit ->	7	6	5	4	3	2	1	0
<b>Command (7)</b>	32H or 33H							
<b>C/D/H (6)</b>	1	LBA	1	Drive	Head (LBA 27-24)			
<b>Cyl High (5)</b>	Cylinder High (LBA 23-16)							
<b>Cyl Low (4)</b>	Cylinder Low (LBA 15-8)							
<b>Sec Num (3)</b>	Sector Number (LBA 7-0)							
<b>Sec Cnt (2)</b>	X							
<b>Feature (1)</b>	X							

This command is provided for compatibility purposes and is similar to the Write Sector(s) command except that it writes 516 bytes instead of 512 bytes. Only single sector Write Long operations are supported. The transfer consists of 512 bytes of data transferred in word mode followed by 4 bytes of ECC transferred in byte

mode. Because of the unique nature of the solid-state CompactFlash Memory Card, the four bytes of ECC transferred by the host cannot be used by the CompactFlash Card. The CompactFlash Card discards these four bytes and writes the sector with valid ECC fields. This command has the same protocol as the Write Sector(s) command.

### 6.1.26 Write Multiple Command - C5H

Bit ->	7	6	5	4	3	2	1	0
<b>Command (7)</b>	C5H							
<b>C/D/H (6)</b>	X	LBA	X	Drive	Head			
<b>Cyl High (5)</b>	Cylinder High							
<b>Cyl Low (4)</b>	Cylinder Low							
<b>Sec Num (3)</b>	Sector Number							
<b>Sec Cnt (2)</b>	Sector Count							
<b>Feature (1)</b>	X							

**Note:** The current revision of the CompactFlash Memory Card only supports a block count of 1 as indicated in the Identify Drive Command information. This command is provided for compatibility with future products which may support a larger block count.

This command is similar to the Write Sectors command. The CompactFlash Memory Card sets BSY within 400 nsec of accepting the command. Interrupts are not presented on each sector but on the transfer of a block which contains the number of sectors defined by Set Multiple. Command

execution is identical to the Write Sectors operation except that the number of sectors defined by the Set Multiple command is transferred without intervening interrupts.

DRQ qualification of the transfer is required only at the start of the data block, not on each sector. The block count of sectors to be transferred without intervening interrupts is programmed by the Set Multiple Mode command, which must be executed prior to the Write Multiple command.

## CompactFlash Memory Card Product Manual

When the Write Multiple command is issued, the Sector Count Register contains the number of sectors (not the number of blocks or the block count) requested. If the number of requested sectors is not evenly divisible by the sector/block, as many full blocks as possible are transferred, followed by a final, partial block transfer. The partial block transfer is for n sectors, where:

$$n = \text{remainder}(\text{sector count} / \text{block count}).$$

If the Write Multiple command is attempted before the Set Multiple Mode command has been executed or when Write Multiple commands are disabled, the Write Multiple operation will be rejected with an aborted command error.

Errors encountered during Write Multiple commands are posted after the attempted writes

of the block or partial block transferred. The Write command ends with the sector in error, even if it is in the middle of a block. Subsequent blocks are not transferred in the event of an error. Interrupts are generated when DRQ is set at the beginning of each block or partial block.

The Command Block Registers contain the cylinder, head and sector number of the sector where the error occurred and the Sector Count Register contains the residual number of sectors that need to be transferred for successful completion of the command e.g. each block has 4 sectors, a request for 8 sectors is issued and an error occurs on the third sector. The Sector Count Register contains 6 and the address is that of the third sector.

---

### 6.1.27 Write Multiple without Erase - CDH

Bit ->	7	6	5	4	3	2	1	0
Command (7)	CDH							
C/D/H (6)	X	LBA	X	Drive	Head			
Cyl High (5)	Cylinder High							
Cyl Low (4)	Cylinder Low							
Sec Num (3)	Sector Number							
Sec Cnt (2)	Sector Count							
Feature (1)	X							

SanDisk does not recommend the use of this command in new designs but it is supported as a normal Write Sectors command for backward compatibility reasons.

## CompactFlash Memory Card Product Manual

### 6.1.28 Write Sector(s) - 30H, 31H

Bit ->	7	6	5	4	3	2	1	0
<b>Command (7)</b>	30H or 31H							
<b>C/D/H (6)</b>	1	LBA	1	Drive	Head (LBA 27-24)			
<b>Cyl High (5)</b>	Cylinder High (LBA 23-16)							
<b>Cyl Low (4)</b>	Cylinder Low (LBA 15-8)							
<b>Sec Num (3)</b>	Sector Number (LBA 7-0)							
<b>Sec Cnt (2)</b>	Sector Count							
<b>Feature (1)</b>	X							

This command writes from 1 to 256 sectors as specified in the Sector Count Register. A sector count of zero requests 256 sectors. The transfer begins at the sector specified in the Sector Number Register. When this command is accepted, the CompactFlash Memory Card sets BSY, then sets DRQ and clears BSY, then waits for the host to fill the sector buffer with the data to be written. No interrupt is generated to start the first buffer fill operation. No data should be transferred by the host until BSY has been cleared by the host.

For multiple sectors, after the first sector of data is in the buffer, BSY will be set and DRQ will be cleared. After the next buffer is ready for data,

BSY is cleared, DRQ is set and an interrupt is generated. When the final sector of data is transferred, BSY is set and DRQ is cleared. It will remain in this state until the command is completed at which time BSY is cleared and an interrupt is generated.

If an error occurs during a write of more than one sector, writing terminates at the sector where the error occurs. The Command Block Registers contain the cylinder, head and sector number of the sector where the error occurred. The host may then read the command block to determine what error has occurred, and on which sector.

### 6.1.29 Write Sector(s) without Erase - 38H

Bit ->	7	6	5	4	3	2	1	0
<b>Command (7)</b>	38H							
<b>C/D/H (6)</b>	1	LBA	1	Drive	Head (LBA 27-24)			
<b>Cyl High (5)</b>	Cylinder High (LBA 23-16)							
<b>Cyl Low (4)</b>	Cylinder Low (LBA 15-8)							
<b>Sec Num (3)</b>	Sector Number (LBA 7-0)							
<b>Sec Cnt (2)</b>	Sector Count							
<b>Feature (1)</b>	X							

SanDisk does not recommend the use of this command in new designs but it is supported as a normal Write Sectors command for backward compatibility reasons.

## CompactFlash Memory Card Product Manual

### 6.1.30 Write Verify Sector(s) - 3CH

Bit ->	7	6	5	4	3	2	1	0
Command (7)	3CH							
C/D/H (6)	1	LBA	1	Drive	Head (LBA 27-24)			
Cyl High (5)	Cylinder High (LBA 23-16)							
Cyl Low (4)	Cylinder Low (LBA 15-8)							
Sec Num (3)	Sector Number (LBA 7-0)							
Sec Cnt (2)	Sector Count							
Feature (1)	X							

This command writes from 1 to 256 sectors as specified in the Sector Count Register. A sector count of zero requests 256 sectors. The transfer begins at the sector specified in the Sector Number Register. When this command is accepted, the CompactFlash Memory Card sets BSY, then sets DRQ and clears BSY, then waits for the host to fill the sector buffer with the data to be written. No interrupt is generated to start the first buffer fill operation. No data should be transferred by the host until BSY has been cleared by the host.

For multiple sectors, after the first sector of data is in the buffer, BSY will be set and DRQ will be cleared. After the next buffer is ready for data,

BSY is cleared, DRQ is set and an interrupt is generated. When the final sector of data is transferred, BSY is set and DRQ is cleared. It will remain in this state until the command is completed at which time BSY is cleared and an interrupt is generated.

If an error occurs during a write of more than one sector, writing terminates at the sector where the error occurs. The Command Block Registers contain the cylinder, head and sector number of the sector where the error occurred. The host may then read the command block to determine what error has occurred, and on which sector.

## CompactFlash Memory Card Product Manual

### 6.2 Error Posting

The following table summarizes the valid status and error value for all the ATA Command set.

**Table 6-7 Error and Status Register**

Command	Error Register					Status Register				
	BBK	UNC	IDNF	ABRT	AMNF	DRDY	DWF	DSC	CORR	ERR
Check Power Mode				V		V	V	V		V
Execute Drive Diagnostic*						V		V		V
Erase Sector(s)	V		V	V	V	V	V	V		V
Format Track			V	V	V	V	V	V		V
Identify Drive				V		V	V	V		V
Idle				V		V	V	V		V
Idle Immediate				V		V	V	V		V
Initialize Drive Parameters						V		V		V
Read Buffer				V		V	V	V		V
Read Multiple	V	V	V	V	V	V	V	V	V	V
Read Long Sector	V		V	V	V	V	V	V		V
Read Sector(s)	V	V	V	V	V	V	V	V	V	V
Read Verify Sectors	V	V	V	V	V	V	V	V	V	V
Recalibrate				V		V	V	V		V
Request Sense				V		V		V		V
Seek			V	V		V	V	V		V
Set Features				V		V	V	V		V
Set Multiple Mode				V		V	V	V		V
Set Sleep Mode				V		V	V	V		V
Stand By				V		V	V	V		V
Stand By Immediate				V		V	V	V		V
Translate Sector	V		V	V	V	V	V	V		V
Wear Level	V	V	V	V	V	V	V	V		V
Write Buffer				V		V	V	V		V
Write Long Sector	V		V	V	V	V	V	V		V
Write Multiple	V		V	V	V	V	V	V		V
Write Multiple w/o Erase	V		V	V	V	V	V	V		V
Write Sector(s)	V		V	V	V	V	V	V		V
Write Sector(s) w/o Erase	V		V	V	V	V	V	V		V
Write Verify Sector(s)	V		V	V	V	V	V	V		V
Invalid Command Code				V		V	V	V		V

V = valid on this command

\* See Table 6-2

**CompactFlash Memory Card Product Manual**



## ***7.0 CIS Description***

This section describes the Card Information Structure (CIS) for the CompactFlash Memory Card.

## CompactFlash Memory Card Product Manual

Attribute Offset	Data	7	6	5	4	3	2	1	0	Description of Contents	CIS Function
000h	01h	CISTPL_DEVICE								Device Info Tuple	Tuple Code
002h	04h									Link is 4 bytes	Link to next tuple
004h	DFh	Dev ID Type Dh = I/O				W 1	Speed 7h = ext			I/O Device, No WPS, ext speed	Device ID, WPS, Speed
006h	72h	X	Spd Mantis Eh == 7.0			Spd Expo 2h=100 nsec			700 nsec if no wait	Extended Speed	
008h	01h	1x				2K units			2 Kilobytes of Address Space	Device Size	
00Ah	FFh	List End Marker								End of Devices	End Marker
00Ch	1Ch	CISTPL_DEVICE_OC								Other Conditions Info Tuple	Tuple Code
00Eh	04h									Link is 4 bytes	Link to next tuple
010h	03h	Reserved 0					3 0	W 1	Conditions: 3V operation is allowed, and WAIT is used		3 Volts Operation, Wait Function
012h	D9h	Dev ID Type Dh = I/O				W 1	Speed 01h=250nsec			I/O Device, No WPS, Speed is 250 nsec with Wait	Device ID, WPS, Speed
014h	01h	1x				2K units			2Kilobytes of Address Space	Device Size	
016h	FFh	List End Marker								End of Devices	End Marker
018h	18h	CISTPL_JEDEC_C								JEDEC ID Common Mem	Tuple Code
01Ah	02h									Link is 2 bytes	Link Length
01Ch	DFh	PCMCIA JEDEC Manufacturer's ID								First Byte of JEDEC ID for SanDisk PC Card-ATA 12V	Byte 1, JEDEC ID of Device 1 (0-2K)
01Eh	01h	PCMCIA Code for PC Card-ATA No Vpp Required								Second Byte of JEDEC ID	Byte 2, JEDEC ID
020h	20h	CISTPL_MANFID								Manufacturer's ID Tuple	Tuple Code
022h	04h									Link is 4 bytes	Link Length
024h	45h	Low Byte of PCMCIA Manufacturer's Code								SanDisk JEDEC Manufacturer's ID	Low Byte of PCMCIA Mfg ID
026h	00h	High Byte of PCMCIA Manufacturer's Code								Code of 0 because other byte is JEDEC 1 byte Manufacturer's ID	High Byte of PCMCIA Mfg ID
028h	01h	Low Byte of Product Code								SanDisk Code for SDP Series	Low Byte Product Code
02Ah	04h	High Byte of Product Code								SanDisk Code for PC CARD ATA	High Byte Product Code ATA

## CompactFlash Memory Card Product Manual

Attribute Offset	Data	7	6	5	4	3	2	1	0	Description of Contents	CIS Function
02Ch	15h	CISTPL_VER_1								Level 1 version / product info	Tuple Code
02Eh	17h									Link to next tuple is 23 bytes	Link Length
030h	04h	TPPLV1_MAJOR								PCMCIA 2.0 /JEIDA 4.1	Major Version
032h	01h	TPPLV1_MINOR								PCMCIA 2.0 /JEIDA 4.1	Minor Version
034h	53h	ASCII Manufacturer String								'S'	String 1
036h	75h									'u'	
038h	6Eh									'n'	
03Ah	44h									'D'	
03Ch	69h									'i'	
03Eh	73h									's'	
040h	6Bh									'k'	
042h	00h	End of Manufacturer String								Null terminator	
044h	53h	ASCII Product Name String								'S'	Info String 2
046h	44h									'D'	
048h	50h									'P'	
04Ah	00h	End of Product Name String								Null terminator	
04Ch	35h									'5'	Info String 3
04Eh	2Fh									'/'	
050h	33h									'3'	
052h	20h									''	
054h	30h	SanDisk Card CIS Revision Number								'0'	
056h	2Eh									'.'	
058h	36h									'6'	
05Ah	00h	End of CIS Revision Number								Null terminator	
05Ch	FFh	End of List Marker								FFh List terminator	No Info String 4

## CompactFlash Memory Card Product Manual

Attribute Offset	Data	7	6	5	4	3	2	1	0	Description of Contents	CIS Function
05Eh	80h	CISTPL_VEND_SPECIF_80								SanDisk Parameters Tuple	Tuple Code
060h	03h	(Field Bytes 3-4 taken as 0)								Link length is 3 byte	Link to next tuple and length of info in this tuple
062h	14h	W	12	NI	PP	P D N A	R I A	R I R	SP	No Wear Level & NO Vpp W:No Wear Level 12:Vpp Not used on Write NI:-INPACK connected PP:Programmable Power PDNA:Pwr Down Not Abort-- Cmd RIA:RBsy, ATBsy connected RIR:RBsy Inhibited at Reset SP:No Security Present This definition applies only to cards with Manufacturer's ID tuple 1st 3 bytes 45 00 01.	SanDisk Fields, 1 to 4 bytes limited by link length.
064h	08h	R	R	R	R	E	T P R	T A R	R8	R8:8 bit ROM present TAR:Temp Bsy on AT Reset TPR:Temp Bsy on PCMCIA -- Reset E:Erase Ahead Available R:Reserved, 0 for now This definition applies only to card with Manufacturer's ID tuple 1st 3 bytes 45 00 01.	SanDisk Fields, 1 to 4 bytes limited by link length.
066h	00h										For Specific platform use Only
068h	21h	CISTPL_FUNCID								Function ID Tuple	Tuple Code
06Ah	02h									Link length is 2 bytes	Link to next tuple
06Ch	04h	Function Type Code								Disk Function	Function Code
06Eh	01h	R	R	R	R	R	R	R	P	Attempt installation at Post P:Install at POST R:Reserved(0)	
070h	22h	CISTPL_FUNCE								Function Extension Tuple	Tuple Code
072h	02h									Link length is 2 bytes	Link to next tuple
074h	01h	Disk Function Extension Tuple Type								Extension tuple describes the Interface Protocol	Extension Tuple Type for Disk
076h	01h	Interface Type Code								PC Card-ATA Interface	Extension Info

## CompactFlash Memory Card Product Manual

Attribute Offset	Data	7	6	5	4	3	2	1	0	Description of Contents	CIS Function	
078h	22h	CISTPL_FUNCCE								Function Extension tuple	Tuple Code	
07Ah	03h									This tuple has 3 info bytes	Link Length	
07Ch	02h	Disk Function Extension Tuple Type								Basic PCMCIA-ATA Extension tuple	Extension Tuple Type for Disk	
07Eh	0Ch	R	R	R	R	U	S		V	No Vpp, Silicon Drive with Unique Manufacturer / Serial Number combined string V=0:No Vpp Required V=1:Vpp on Modify Media V=2:Vpp on any operation V=3:Vpp continuous S:Silicon, else Rotating U:ID Drive Mfg/SN Unique	Basic ATA Option Parameters	
		0	0	0	0	1	1		0			
080h	0Fh	R	I	E	N	P3	P2	P1	P0	All power down modes and power commands are not needed to minimize power. P0:Sleep Mode Supported P1:Standby Mode Supported P2:Idle Mode Supported P3:Drive Auto Power Control N:Some Config Excludes 3X7 E:Index Bit is Emulated I:Twin -IOis16 Data Reg Only	Extended ATA Option Parameters	
		0	0	0	0	1	1	1	1			
082h	1Ah	CISTPL_CONF								Configuration Tuple	Tuple Code	
084h	05h									Link Length is 5 bytes	Link to next tuple	
086h	01h	RFS		RMS		RAS					Size of Reserved Field is 0 bytes, Size of Register Mask is 1 Byte, Size of Config Base Address is 2 bytes RFS:Bytes in Reserved Field RMS:Bytes in Reg Mask-1 RAS:Bytes in Base Addr-1	Size of fields byte (TPCC_SZ)
		00		00		01						
088h	07h	TPCC_LAST								Entry with Config Index of 07h is final entry in table	Last entry of configuration table	
08Ah	00h	TPCC_RADR (lsb)								Configuration Registers are located at 200h in Reg Space.	Location of Config Registers	
08Ch	02h	TPCC_RADR (msb)										
08Eh	0Fh	R	R	R	R	S	P	C	I	First 4 Configuration Registers are present I:Configuration Index C:Configuration and Status P:Pin Replacement S:Socket and Copy R:Reserved for future use	TPCC_RMSK	
		0	0	0	0	1	1	1	1			

## CompactFlash Memory Card Product Manual

Attribute Offset	Data	7	6	5	4	3	2	1	0	Description of Contents	CIS Function		
090h	1Bh	CISTPL_CE								Configuration Entry Tuple	Tuple Code		
092h	0Bh									Link to next tuple is 11 bytes. Also limits size of this tuple to 13 bytes.	Link to next tuple		
094h	C0h	I	D	Configuration Index								<b>Memory Mapped I/O Configuration</b> Configuration Index for this entry is 0. Interface Byte follows this byte. Default Configuration, so is not dependent on previous Default Configuration. D:Default Configuration I:Interface Byte Follows	TPCE_INDXX
		1	1	0									
096h	C0h	W	R	P	B	Interface Type					Memory Only Interface(0), Bvd's and wProt not used, Ready/-Busy and Wait for memory cycles active. B:Battery Volt Detects Used P:Write Protect Used R:Ready/-Busy Used W:Wait Used for Memory Cycles	TPCE_IF	
		1	1	0	0	0							
098h	A1h	M	MS	IR	IO	T	P					Vcc only Power; No Timing, I/O, or IRQ; 2 Byte Mem Space Length; Misc Entry Present P:Power info type T:Timing info present IO:I/O port info present IR:Interrupt info present MS:Mem space info type M:Misc info byte(s) present	TPCE_FS
		1	1	0	0	0	1						
09Ah	27h	R	DI	PI	AI	SI	HV	LV	NV	Nominal Voltage Follows NV:Nominal Voltage LV:Minimum Voltage HB:Maximum Voltage SI:Static Current AI:Average Current PI:Peak Current DI:Power Down Current	Power Parameters for Vcc		
		0	0	1	0	0	1	1	1				
09Ch	55h	X	Mantissa			Exponent						Vcc Nominal is 5 Volts	Vcc Nominal Value
		0	Ah = 5.0			5h = 1V							
09Eh	4Dh	X	Mantissa			Exponent						Vcc Nominal is 4.5 Volts	Vcc Minimum Value
		0	9h = 4.5			5h = 1V							
0A0h	5Dh	X	Mantissa			Exponent						Vcc Nominal is 5.5 Volts	Vcc Maximum Value
		0	Bh = 5.5			5h = 1V							

## CompactFlash Memory Card Product Manual

Attribute Offset	Data	7	6	5	4	3	2	1	0	Description of Contents	CIS Function		
0A2h	75h	X 0	Mantissa Eh = 8.0			Exponent 5h = 10					Max Average Current over 10 msec is 80 mA	Max Average Current	
0A4h	08h	Length in 256 bytes pages (lsb)									Length of Mem Space is 2 KB	TPCE_MS Length LSB	
0A6h	00h	Length in 256 bytes pages (msb)									Start at 0 on card	TPCE_MS Length MSB	
0A8h	21h	X  0	R  0	P  1	RO  0	A  0	T  1			Power-Down, and Twin Card. T:Twin Cards Allowed A:Audio Supported RO:Read Only Mode P:Power Down Supported R:Reserved X:More Misc Fields Bytes	TPCE_MI		
0AAh	1Bh	CISTPL_CE									Configuration Entry Tuple	Tuple Code	
0ACh	06h										Link to next tuple is 6 bytes. Also limits size of this tuple to 8 bytes.	Link to next tuple	
0AEh	00h	I  0	D  0	Configuration Index  0							Memory mapped I/O 3.3V configuration.	TPCE_INDX	
0B0h	01h	M  0	MS  0		IR  0	IO  0	T  0	P  1		P:Power info type	TPCE_FS		
0B2h	21h	R  0	DI  0	PI  1	AI  0	SI  0	H  0	LV  0	NV  1	PI:Peak Current NV:Nominal Operation Supply Voltage	TPCE_PD		
0B4h	B5h	X 1	Mantissa 6h = 3.0			Exponent 5h = 1					Nominal Operation Supply Voltage = 3.0V	Nominal Operation Supply Voltage	
0B6h	1Eh	X 0	1Eh									+ .30	Nominal Operation Supply Voltage Extension Byte
0B8h	4Dh	X 0	Mantissa 9h = 4.5			Exponent 5h = 10					Max Average Current over 10 msec is 45mA	Max Average Current	

## CompactFlash Memory Card Product Manual

Attribute Offset	Data	7	6	5	4	3	2	1	0	Description of Contents	CIS Function		
0BAh	1Bh	CISTPL_CE								Configuration Entry Tuple	Tuple Code		
0BCh	0Dh									Link to next tuple is 13 bytes. Also limits size of this tuple to 15 bytes.	Link to next tuple		
0BEh	C1h	I	D	Configuration Index								<b>I/O Mapped Contiguous 16 registers configuration</b> Configuration Index for this entry is 1. Interface Byte follows this byte. Default Configuration, so is not dependent on previous Default Configuration. D:Default Configuration I:Interface Byte Follows	TPCE_INDX
		1	1	1									
0C0h	41h	W	R	P	B	Interface Type					I/O Interface(1), Bvd's and wProt not used; Ready/-Busy active but Wait not used for memory cycles. B:Battery Volt Detects Used P:Write Protect Used R:Ready/-Busy Used W:Wait Used for Memory Cycles	TPCE_IF	
		0	1	0	0	1							
0C2h	99h	M	MS	IR	IO	T	P					Vcc Only Power Descriptors; No Timing; I/O and IRQ present; No Mem Space; Misc Entry Present P:Power info type T:Timing info present IO:I/O port info present IR:Interrupt info present MS:Mem space info type M:Misc info byte(s) present	TPCE_FS
		1	0	1	1	0	1						
0C4h	27h	R	DI	PI	AI	SI	HV	LV	NV	Nominal Voltage Follows NV:Nominal Voltage LV:Minimum Voltage HB:Maximum Voltage SI:Static Current AI:Average Current PI:Peak Current DI:Power Down Current	Power Parameters for Vcc		
		0	0	1	0	0	1	1	1				
0C6h	55h	X	Mantissa				Exponent			Vcc Nominal is 5Volts	Vcc Nominal Value		
		0	Ah = 5.0				5h = 1V						
0C8h	4Dh	X	Mantissa				Exponent			Vcc Nominal is 4.5 Volts	Vcc Minimum Value		
		0	9h = 4.5				5h = 1V						
0CAh	5Dh	X	Mantissa				Exponent			Vcc Nominal is 5.5Volts	Vcc Maximum Value		
		0	Bh = 5.5				5h = 1V						



## CompactFlash Memory Card Product Manual

Attribute Offset	Data	7	6	5	4	3	2	1	0	Description of Contents	CIS Function	
0CCh	75h	X 0	Mantissa Eh = 8.0			Exponent 5h = 10					Max Average Current over 10 msec is 80 mA	Max Average Current
0CEh	64h	R 0	S 1	E 1	IO AddrLines 4					Supports both 8 and 16 bit I/O hosts. 4 Address lines and no range so 16 registers and host must do all selection decoding. IO AddrLines:#lines decoded E:Eight bit only hosts supported S:Sixteen bit hosts supported R:Range Follows	TPCE_IO	
0D0h	F0h	S 1	P 1	L 1	M 1	V 0	B 0	I 0	N 0	IRQ Sharing Logic Active in Card Control & Status Register, Pulse and Level Mode Interrupts supported, Recommended IRQ's any of 0 through 15(F) S:Share Logic Active P:Pulse Mode IRQ Supported L:Level Mode IRQ Supported M:Bit Mask of IRQs Present V:Vendor Unique IRQ B:Bus Error IRQ I:IO Check IRQ N:Non-Maskable IRQ	TPCE_IR	
0D2h	FFh	7 1	6 1	5 1	4 1	3 1	2 1	1 1	0 1	IRQ Levels to be routed 0 - 15 recommended.	TPCE_IR Mask Extension Byte 1	
0D4h	FFh	F 1	E 1	D 1	C 1	B 1	A 1	9 1	8 1	Recommended routing to any "normal, maskable" IRQ.	TPCE_IR Mask Extension Byte 2	
0D6h	21h	X 0	R 0	P 1	RO 0	A 0	T 1			Power-Down, and Twin Card. T:Twin Cards Allowed A:Audio Supported RO:Read Only Mode P:Power Down Supported R:Reserved X:More Misc Fields Bytes	TPCE_MI	

## CompactFlash Memory Card Product Manual

Attribute Offset	Data	7	6	5	4	3	2	1	0	Description of Contents	CIS Function	
0D8h	1Bh	CISTPL_CE								Configuration Entry Tuple	Tuple Code	
0DAh	06h									Link to next tuple is 6 bytes. Also limits size of this tuple to 8 bytes.	Link to next tuple	
0DCh	01h	I	D	Configuration Index							I/O mapped contiguous 16 3.3V configuration	TPCE_INDX
		0	0	1								
0DEh	01h	M	MS	IR	IO	T	P			P:Power info type	TPCE_FS	
		0	0	0	0	0	1					
0E0h	21h	R	DI	PI	AI	SI	HV	LV	NV	PI:Peak Current NV:Nominal Operation Supply Voltage	Power Parameters for Vcc	
		0	0	1	0	0	0	0	1			
0E2h	B5h	X	Mantissa			Exponent					Nominal Operation Supply Voltage = 3.0V	Nominal Operation Supply Voltage
		1	6h = 3.0			5h = 1						
0E4h	1Eh	X	1Eh								+ .30	Nominal Operation Supply Voltage Extension Byte
		0										
0E6h	4Dh	X	Mantissa			Exponent					Max Average Current over 10 msec is 45 mA	Max Average Current
		0	9h = 4.5			5h = 10						
0E8h	1Bh	CISTPL_CE								Configuration Entry Tuple	Tuple Code	
0EAh	12h									Link to next tuple is 18 bytes. Also limits size of this tuple to 20 bytes.	Link to next tuple	
0ECh	C2h	I	D	Configuration Index							<b>AT Fixed Disk Primary I/O Address Configuration</b> Configuration Index for this entry is 2. Interface Byte follows this byte. Default Configuration	TPCE_INDX
		1	1	2								
0EEh	41h	W	R	P	B	Interface Type				I/O Interface(1), Bvd's and wProt not used; Ready/-Busy active but Wait not used for memory cycles. B:Battery Volt Detects Used P:Write Protect Used R:Ready/-Busy Used W:Wait Used for Memory Cycles	TPCE_IF	
		0	1	0	0	1						

## CompactFlash Memory Card Product Manual

Attribute Offset	Data	7	6	5	4	3	2	1	0	Description of Contents	CIS Function	
0F0h	99h	M 1	MS 0	IR 1	IO 1	T 0	P 1			Vcc Only Power Description; No Timing; I/O and IRQ present; No Mem Space; Misc Entry present P:Power info type T:Timing info present IO:I/O port info present IR:Interrupt info present MS:Mem space info type M:Misc info byte(s) present	TPCE_FS	
0F2h	27h	R 0	DI 0	PI 1	AI 0	SI 0	HV 1	LV 1	NV 1	Nominal Voltage Follows NV:Nominal Voltage LV:Minimum Voltage HB:Maximum Voltage SI:Static Current AI:Average Current PI:Peak Current DI:Power Down Current	Power Parameters for Vcc	
0F4h	55h	X 0	Mantissa Ah = 5.0			Exponent 5h = 1V					Vcc Nominal is 5Volts	Vcc Nominal Value
0F6h	4Dh	X 0	Mantissa 9h = 4.5			Exponent 5h = 1V					Vcc Nominal is 4.5Volts	Vcc Minimum Value
0F8h	5Dh	X 0	Mantissa Bh = 5.5			Exponent 5h = 1V					Vcc Nominal is 5.5Volts	Vcc Maximum Value
0FAh	75h	X 0	Mantissa Eh = 8.0			Exponent 5h = 10					Max Average Current over 10 msec is 80 mA	Max Average Current
0FCh	EAh	R 1	S 1	E 1	IO AddrLines Ah = 10					Supports both 8 and 16 bit I/O hosts. 10 Address lines with range so card will respond only to indicated (1F0-1F7, 3F6-3F7) on A9 through A0 for I/O cycles. IO AddrLines:#lines decoded E:Eight bit only hosts supported S:Sixteen bit hosts supported R:Range Follows	TPCE_IO	

## CompactFlash Memory Card Product Manual

Attribute Offset	Data	7	6	5	4	3	2	1	0	Description of Contents	CIS Function
0FEh	61h	LS 1	AS 2	N Ranges - 1 1						Number of Ranges is 2; Size of each address is 2 bytes; Size of each length is 1 byte. AS:Size of Addresses 0:No Address Present 1:1Byte (8 bit) Addresses 2:2Byte (16 bit) Addresses 3:4Byte (32 bit) Addresses LS:Size of length 0:No Lengths Present 1:1Byte (8 bit) Lengths 2:2Byte (16 bit) Lengths 3:4Byte (32 bit) Lengths	I/O Range Format Description
100h	F0h	1st I/O Base Address (lsb)			First I/O Range base is						
102h	01h	1st I/O Base Address (msb)			1F0h						
104h	07h	1st I/O Range Length - 1			8 bytes total ==> 1F0-1F7h			I/O Length - 1			
106h	F6h	2nd I/O Base Address (lsb)			2nd I/O Range base is						
108h	03h	2nd I/O Base Address (msb)			3F6h						
10Ah	01h	2nd I/O Range Length - 1			2 bytes total ==> 3F6-3F7h			I/O Length - 1			
10Ch	EEh	S 1	P 1	L 1	M 0	Recommend IRQ Level Eh = 14			IRQ Sharing Logic Active in Card Control & Status Register, Pulse and Level Mode Interrupts supported, Recommended IRQ's any of 0 through 15(F) S:Share Logic Active P:Pulse Mode IRQ Supported L:Level Mode IRQ Supported M:Bit Mask of IRQs Present M=0 so bits 3-0 are single level, binary encoded	TPCE_IR	
10Eh	21h	X 0	R 0	P 1	RO 0	A 0	T 1			Power-Down, and Twin Card. T:Twin Cards Allowed A:Audio Supported RO:Read Only Mode P:Power Down Supported R:Reserved X:More Misc Fields Bytes	TPCE_MI

## CompactFlash Memory Card Product Manual

Attribute Offset	Data	7	6	5	4	3	2	1	0	Description of Contents	CIS Function	
110h	1Bh	CISTPL_CE								Configuration Entry Tuple	Tuple Code	
112h	06h									Link to next tuple is 6 bytes. Also limits size of this tuple to 8 bytes.	Link to next tuple	
114h	02h	I	D	Configuration Index							AT Fixed Disk Primary I/O 3.3V configuration	TPCE_INDX
		0	0	2								
116h	01h	M	MS	IR	IO	T	P				P:Power info type	TPCE_FS
		0	0	0	0	0	1					
118h	21h	R	DI	PI	AI	SI	HV	LV	NV	PI:Peak Current NV:Nominal Operation Supply Voltage	Power Parameters for Vcc	
		0	0	1	0	0	0	0	1			
11Ah	B5h	X	Mantissa			Exponent			Nominal Operation Supply Voltage = 3.0V			Nominal Operation Supply Voltage
		1	6h = 3.0			5h = 1						
11Ch	1Eh	X	1Eh								+30	Nominal Operation Supply Voltage Extension Byte
		0										
11Eh	4Dh	X	Mantissa			Exponent			Max Average Current over 10 msec is 45mA			Max Average Current
		0	9h = 4.5			5h = 10						

## CompactFlash Memory Card Product Manual

Attribute Offset	Data	7	6	5	4	3	2	1	0	Description of Contents	CIS Function		
120h	1Bh	CISTPL_CE								Configuration Entry Tuple	Tuple Code		
122h	12h									Link to next tuple is 18 bytes. Also limits size of this tuple to 20 bytes.	Link to next tuple		
124h	C3h	I	D	Configuration Index							<b>AT Fixed Disk Secondary I/O Address Configuration</b> Configuration Index for this entry is 3. Interface Byte follows this byte. Default Configuration	TPCE_INDXX	
		1	1	3									
126h	41h	W	R	P	B	Interface Type					I/O Interface(1), Bvd's and wProt not used; Ready/-Busy active but Wait not used for memory cycles. B:Battery Volt Detects Used P:Write Protect Used R:Ready/-Busy Used W:Wait Used for Memory Cycles	TPCE_IF	
		0	1	0	0	1							
128h	99h	M	MS	IR	IO	T	P					Vcc Only Power Descriptors; No Timing; I/O and IRQ present; No Mem Space; Misc Entry Present. P:Power info type T:Timing info present IO:I/O port info present IR:Interrupt info present MS:Mem space info type M:Misc info byte(s) present	TPCE_FS
		1	0	1	1	0	1						
12Ah	27h	R	DI	PI	AI	SI	HV	LV	NV	Nominal Voltage Follows NV:Nominal Voltage LV:Minimum Voltage HB:Maximum Voltage SI:Static Current AI:Average Current PI:Peak Current DI:Power Down Current	Power Parameters for Vcc		
		0	0	1	0	0	1	1	1				
12Ch	55h	X	Mantissa			Exponent			Vcc Nominal is 5Volts			Vcc Nominal Value	
		0	Ah = 5.0			5h = 1V							
12Eh	4Dh	X	Mantissa			Exponent			Vcc Nominal is 4.5Volts			Vcc Minimum Value	
		0	9h = 4.5			5h = 1V							
130h	5Dh	X	Mantissa			Exponent			Vcc Nominal is 5.5Volts			Vcc Maximum Value	
		0	Bh = 5.5			5h = 1V							
132h	75h	X	Mantissa			Exponent			Max Average Current over 10 msec is 80 mA			Max Average Current	
		0	Eh = 1.0			5h = 10							

## CompactFlash Memory Card Product Manual

Attribute Offset	Data	7	6	5	4	3	2	1	0	Description of Contents	CIS Function
134h	EAh	R	S	E	IO AddrLines Ah = 10					Supports both 8 and 16 bit I/O hosts. 10 Address lines with range so card will respond only to indicated (170-177, 376-377) on A9 through A0 for I/O cycles. IO AddrLines:#lines decoded E:Eight bit only hosts supported S:Sixteen bit hosts supported R:Range Follows	TPCE_IO
136h	61h	LS		AS		N Ranges - 1				Number of Ranges is 2; Size of each address is 2 bytes; Size of each length is 1 byte. AS:Size of Addresses 0:No Address Present 1:1Byte (8 bit) Addresses 2:2Byte (16 bit) Addresses 3:4Byte (32 bit) Addresses LS:Size of length 0:No Lengths Present 1:1Byte (8 bit) Lengths 2:2Byte (16 bit) Lengths 3:4Byte (32 bit) Lengths	I/O Range Format Description
138h	70h	1st I/O Base Address (lsb)								First I/O Range base is 170h	
13Ah	01h	1st I/O Base Address (msb)									
13Ch	07h	1st I/O Range Length - 1								8 bytes total ==> 170-177h	I/O Length - 1
13Eh	76h	2nd I/O Base Address (lsb)								2nd I/O Range base is 376h	
140h	03h	2nd I/O Base Address (msb)									
142h	01h	2nd I/O Range Length - 1								2 bytes total ==> 376-377h	I/O Length - 1
144h	EEh	S	P	L	M	Recommend IRQ Level Eh = 14				IRQ Sharing Logic Active in Card Control & Status Register, Pulse and Level Mode Interrupts supported, Recommended IRQ's any of 0 through 15(F) S:Share Logic Active P:Pulse Mode IRQ Supported L:Level Mode IRQ Supported M:Bit Mask of IRQs Present M=0 so bits 3-0 are single level, binary encoded	TPCE_IR

## CompactFlash Memory Card Product Manual

Attribute Offset	Data	7	6	5	4	3	2	1	0	Description of Contents	CIS Function	
146h	21h	X	R	P	RO	A	T			Power-Down, and Twin Card. T:Twin Cards Allowed A:Audio Supported RO:Read Only Mode P:Power Down Supported R:Reserved X:More Misc Fields Bytes	TPCE_MI	
		0	0	1	0	0	1					
148h	1Bh	CISTPL_CE								Configuration Entry Tuple	Tuple Code	
14Ah	06h									Link to next tuple is 6 bytes. Also limits size of this tuple to 8 bytes.	Link to next tuple	
14Ch	03h	I	D	Configuration Index							AT Fixed Disk Secondary I/O 3.3V configuration	TPCE_INDX
		0	0	3								
14Eh	01h	M	MS	IR	IO	T	P			P:Power info type	TPCE_FS	
		0	0	0	0	0	1					
150h	21h	R	DI	PI	AI	SI	HV	LV	NV	PI:Peak Current NV:Nominal Operation Supply Voltage	Power Parameters for Vcc	
		0	0	1	0	0	0	0	1			
152h	B5h	X	Mantissa 6h = 3.0				Exponent 5h = 1			Nominal Operation Supply Voltage = 3.0V	Nominal Operation Supply Voltage	
		1										
154h	1Eh	X	1Eh				+.30			Nominal Operation Supply Voltage Extension Byte		
		0										
156h	4Dh	X	Mantissa 9h = 4.5				Exponent 5h = 10			Max Average Current over 10 msec is 45mA	Max Average Current	
		0										
158h	1Bh	CISTPL_CE								Configuration Entry Tuple	Tuple Code	
15Ah	04h									Link to next tuple is 4 bytes.	Link to next tuple	
15Ch	07h	I	D	Configuration Index							AT Fixed Disk Secondary I/O 3.3V configuration	TPCE_INDX
		0	0	7								
15Eh	00h	M	MS	IR	IO	T	P			P:Power info type	TPCE_FS	
		0	0	0	0	0	0					
160h	028h									SanDisk Code	Reserved	
162h	0D3h									SanDisk Code	Reserved	
164h	014h	CISTPL_NO_LINK								Prevent Scan of Common Memory	Tuple Code	
166h	000h	No Bytes Following								Link Length is 0 Bytes	Link to next tuple	
168h	0FFh	End of Tuple Chain								End of CIS	Tuple Code	



# **Ordering Information and Technical Support**



### Ordering Information

To order SanDisk products directly from SanDisk, call 408-542-0595.

#### **CompactFlash Memory Card**

Model SDCFBX-YY-101

Where: X:	I	Industrial temperature grade
	(blank)	Standard temperature grade
YY:	8	8.02 MB
	16	16.05 MB
	32	32.11 MB
	48	48.10 MB
	64	64.22 MB
	80	80.21 MB
	96	96.20 MB
	128	128.45 MB
	160	160.43 MB
	192	192.41 MB

Model SDCF2BX-YY-101

Where: X:	I	Industrial temperature grade
	(blank)	Standard temperature grade
YY:	256	256.90 MB
	300	300.36 MB

#### **SanDisk ImageMate™**

The SanDisk ImageMate flash memory external drive transfers pictures, music and more in a flash. Simply drag and drop files from the flash card to your hard drive and back. SanDisk offers a variety of ImageMates (parallel port or USB) for various types of Flash Memory.

For more information or to order the ImageMate, call 408-542-0595.

#### **CompactFlash Memory Card Evaluation Kit**

The CompactFlash Memory Card Evaluation Kit (Model SDCFEV-01) permits designers to quickly and easily evaluate the CompactFlash Card.

The CompactFlash Memory Card Evaluation Kit (Model SDCFEV-01) includes the following items:

##### *Hardware*

- Evaluation adapter board
- CompactFlash Memory Card
- CF Adapter
- Card extender
- IDE-AB7 adapter board
- 50 position surface mount header with co-planar tails
- 50 position straddle mount header for CF Adapter

##### *Software*

- FlashDisk Driver and Utilities 3.5-inch diskette

##### *Documentation*

- Read Me First flyer
- CompactFlash Evaluation Kit User's Guide
- Applications Note: Differences between PC Card ATA and CF

#### **Model SDCFEV-01**

To order, or for more information call:  
408-542-0595.

## Ordering Information and Technical Support

---

### *System Software, Card Reader/Writers and Connectors Compatible with SanDisk CompactFlash Memory Cards*

**Table 1 System Software with SanDisk CompactFlash Memory Card Support**

Vendor	Product Name	Telephone Number
AMI	AMICARDZ	770-263-8181
Award/VMI	Cardware	415-968-4433
Databook	Card Talk for Databook Chip	508-762-9779
Phoenix	Phoenix Card Manager Plus	714-440-8000
SystemSoft	Card Soft	508-651-0088
Vadem	Socket Services for VG365, VG465, VG468	408-467-2100

**Table 2 Card Readers/Writers Compatible with SanDisk CompactFlash Memory Cards**

Below is a list of PC card reader/writers that are compatible with the SanDisk CompactFlash Memory Card when used with a passive Type II adapter. These reader/writers can be installed in desktop PCs to enable the CompactFlash Memory Card to be used in those systems. The CompactFlash Memory Card will operate in any of these reader/writers when used with a passive Type II adapter.

Note: The SanDisk ImageMate, listed below, does not require use of a Type II adapter.

Vendor	Country	Telephone/FAX Number	Product Model	Product Type
Adtron	United States	602-926-9324 FAX 602-926-9359 <a href="http://www.adtron.com">http://www.adtron.com</a>	SDDA	Adapter for direct IDE-mode operation; 16-bit data interface, BIOS compatible (no drivers); 3.5- or 2.5-inch mount; can replace laptop hard drives.
			SDDB	IDE or ISA connected 8-bit drive; front access.
			SDDC	Industry standard ISA dual-slot adapter, rear entry, cabled to front entry or 100% internal access.
			SDDL	External LPT port drive.
			SDDM	8-bit PC/104 drive.
			SDDP	16-bit PC/104 industry standard adapter.
			SDDR	External RS-232 drive.
			SDDS	Dual-slot SCSI bus drive; ATA card appears as removable disk device; compatible with PC, Macintosh and most workstations.

## Ordering Information and Technical Support

**Table 2 Card Readers/Writers Compatible with SanDisk CompactFlash Memory Cards (continued)**

Vendor	Country	Telephone/FAX Number	Product Model	Product Type
Altec	Germany	Country Code 49 (0) 511 98381-0 FAX (0) 511 98381-49	EasyDrive	Triple slot (two Type II or one Type II and one Type III) in 3.5-inch frame; IDE interface.
			PCBoardCard	Dual slot (two Type II or one Type III) on ISA slot card.
			i-Drive	Dual slot (two Type II or one Type III) in a 3.5-inch frame; SCSI-2 interface.
			PC/104 Drive	Dual slot (two Type II or one Type III) for PC/104 system bus.
CardWize Data Solutions	United Kingdom	Country Code 44 118-947-9475 FAX 118-947-4676 Email pcmcia@cardwize.co.uk	MiniWizard 1R WIZ/001	ISA adapter with one rear access slot.
			MiniWizard 2R WIZ/006	ISA adapter with two rear mounted slots.
			CardWizard 1F1R WIZ/101	ISA adapter with one FDD bay mounted slot and one rear access slot.
			CardWizard 2F WIZ/106	ISA adapter with two FDD bay mounted slots.
			CardWizard EXT WIZ/107	ISA adapter with external slot housed in a robust metal case.
			CardWizard IP54 WIZ/108	ISA adapter with one slot IP54 sealed and one rear access slot.
			CardWizard Bezel WIZ/109	ISA adapter with one slot via the standard CardWize bezel and one rear access slot.
			PC104 Wizard 1 WIZ/201	PC104 bus adapter with one slot on board.
			PC104 Wizard 1+H WIZ/202	PC104 bus adapter with one slot on board and headers for remote access slot two.
			PC104 Wizard Stack WIZ/211	PC104 bus adapter with two stacking slots.
			PC104 Wizard Bezel WIZ/221	PC104 bus adapter with one PC104 slot and one bezel mounted slot.
			PC104 Wizard FDD WIZ/231	PC104 bus adapter with one PC104 slot and one FDD bay mounted slot.
			PC104 Wizard IP54 WIZ/241	PC104 bus adapter with one PC104 slot and 1 slot IP54 sealed.
			CardMaestro 3.5" MAE/000	IDE adapter for direct IDE mode 3.5" & 5.25" FDD bay mounted.
			CardMaestro 3.5" PCB MAE/050	IDE adapter PCB on a 3.5"HDD foot print.
CardMaestro EXT MAE/300	IDE adapter with an external slot.			
CardMaestro 2.5" MAE/400	IDE adapter on a 2.5" HDD foot print.			

## Ordering Information and Technical Support

**Table 2 Card Readers/Writers Compatible with SanDisk CompactFlash Memory Cards (continued)**

Vendor	Country	Telephone/FAX Number	Product Model	Product Type
Chase/CNF	United States  United Kingdom	408-778-1160 FAX 408-779-6558  Country Code 44 (0) 1274 841358 FAX (0) 1274 841316	CARDport isa	ISA adapter with one slot on card and cable to single slot drive bay mounted unit.
CSM	Germany	Country Code 49 (0) 711 7796420 FAX (0) 711 7796440	OmniDrive  Professional Drive  Dual Front Board Dual Slot Board  CIS-I/O Board	Single slot (Type III) external unit that connects to Centronics (EPP) port (supports Windows NT, Windows 95, Windows 3.11 and MS-DOS).  Single slot (Type III) external unit that connects to Centronics (EPP) port with professional software for binary data access.  ISA adapter with cable to dual slot (one Type III and one Type II) in a 3.5-inch frame.  ISA adapter with one slot (Type III) on card and cable to single slot (Type III) in a 3.5-inch frame.  ISA adapter with one slot (Type III) on card.
Greystone	United States	408-866-4739 FAX 408-866-8328	CardDock	ISA adapter with cable to dual slot drive bay mounted unit.
Intermart	United States  Japan	408-379-0770 FAX 408-379-3666  Country Code 81 3-5489-8301 FAX 3-5489-8310	PCD-15  PCD-10  PCD-15B	Dual slot external unit that connects to SCSI-2 port. (Supports Apple Macintosh, UNIX, Risc, Vme and PowerPC platforms.)  Single slot external unit that connects to SCSI-2 port. Same platform support as PCD-15.  Internal configuration of PCD-15 for use as built-in for desktop systems.
Karby Corp.	United States	716-889-4204 FAX 716-889-2593	TDM 650 ThinCard Drive  TMB 240 ThinCard Drive	Single slot external unit connected to Parallel Port.  ISA adapter with cable to single slot internal unit.
Protege	United States	714-450-8950 FAX 714-450-8959	ATA/X	ISA adapter with single cable to either an internal or external unit.
SanDisk	United States	408-542-0500 FAX 408-542-0503 <a href="http://www.sandisk.com">http://www.sandisk.com</a>	ImageMate	CompactFlash Card reader/writer that connects to PC with printer pass through connector. Does not require Type II adapter.

## **Ordering Information and Technical Support**

**Table 3 CompactFlash Connector Vendors**

The table below lists vendors that can supply CompactFlash connectors.

<b>Vendor Name</b>	<b>Telephone Number</b>
3M Company	800-225-5373
Amp Incorporated	800-522-6752 (USA only) 717-986-7777 (outside USA)
Hirose Electric Incorporated	805-522-7958
Molex Incorporated	630-969-4550

## **Ordering Information and Technical Support**

### ***Technical Support Services***

---

#### ***Direct SanDisk Technical Support***

Call SanDisk Applications Engineering at 408-542-0405 for technical support.

---

#### ***SanDisk Worldwide Web Site***

Internet users can obtain technical support and product information along with SanDisk news and much more from the SanDisk Worldwide Web Site, 24 hours a day, seven days a week. The SanDisk Worldwide Web Site is frequently updated. Visit this site often to obtain the most up-to-date information on SanDisk products and applications. The SanDisk Web Site URL is <http://www.sandisk.com>.



# **SanDisk Sales Offices**

**SanDisk Worldwide Sales Offices**

## ***SanDisk Worldwide Sales Offices***

### ***Americas***

#### **SanDisk Corporate Headquarters**

140 Caspian Court  
Sunnyvale, CA 94089-9820  
408-542-0500  
FAX 408-542-0503  
<http://www.sandisk.com>

### ***Sales Offices***

#### **Western Region USA**

408-542-0730  
FAX 408-542-0403

#### **Eastern Region USA & Canada**

603-882-0888  
FAX 603-882-2207

#### **Central & Southern Region USA**

614-760-3700  
FAX 614-760-3701

#### **Latin & South America**

407-667-4880  
FAX 407-667-4834

### ***Europe***

#### **SanDisk GmbH**

Karlsruher Str. 2C  
D-30519 Hannover, Germany  
49-511-8759185  
FAX 49-511-8759187

#### **SanDisk Northern Europe**

Videroegaten 3 B  
S-16440 Kista  
Sweden  
46-(0)8-75084-63  
FAX 46-(0)8-75084-26

#### **SanDisk Central Europe**

Eutelis Plaz 3  
D-40878 Ratingen  
Germany  
49-2102-999666  
FAX 49-2102-999667

### ***Japan***

#### **SanDisk K.K.**

8F Nisso Bldg. 15  
2-17-19 Shin-Yokohama, Kohoku-ku  
Yokohama 222-0033, Japan  
81-45-474-0181  
FAX 81-45-474-0371

### ***Asia/Pacific Rim***

89 Queensway, Lippo Center  
Tower II, Suite 4104  
Admiralty, Hong Kong  
852-2712-0501  
FAX 852-2712-9385

To order SanDisk products directly from SanDisk,  
call 408-542-0595.

**SanDisk Worldwide Sales Offices**

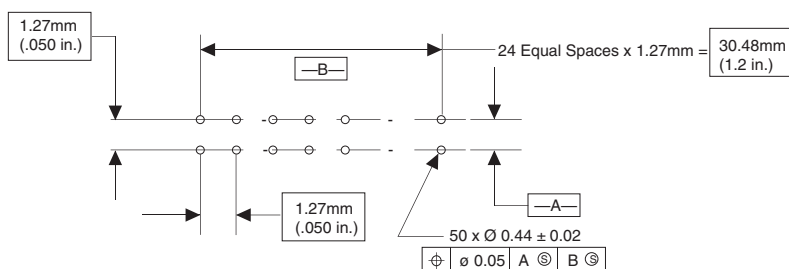
## Appendix CompactFlash Connector Specifications

# Appendix CompactFlash Connector Specifications

This appendix includes specifications for CompactFlash connectors as defined by the CompactFlash Association. See the Ordering Information section of this manual for a list of CompactFlash connector vendors.

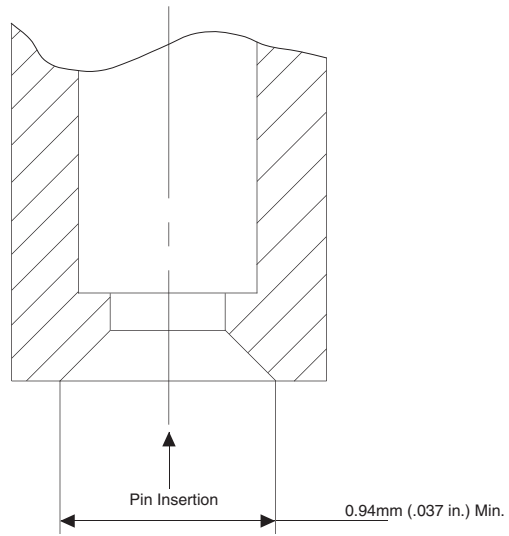
**Table 1 Connector Interface Requirements**

Category	Item	Standard	Test Method
Physical	Housing Material	High Temperature Plastic	
	Housing Flammability Rating	UL 94V-0	Certification
Electrical Performance	Contact Resistance (w/ bulk)	40 milliohms maximum, initial 20 milliohms maximum change, throughout testing	EIA-364-23A
	Current Rating	0.5 Amperes per contact, without exceeding 30°C temperature rise above ambient	IEC-512-PT3
	Insulation Resistance	1000 Megaohms minimum, initial 100 Megaohms minimum, after 1 minute at 500 Vdc	EIA-364-21A
	Dielectric Withstanding Voltage	No shorting during 1 minute at 500 Vac rms, with 1 mA maximum current leakage	EIA-364-20A
Mechanical Performance	Single Socket Holding Force	4.9 N minimum push out at 25 mm/minute	EIA-364-29A
	Single Pin Holding Force	9.8 N minimum push out at 25 mm/minute	EIA-364-29A
	Total Mating Force	28.8 N maximum at 25 mm/minute	EIA-364-13A
	Total Unmating Force	4.9 N minimum and 28.8 N maximum at 25 mm/minute	EIA-364-13A
	Durability	10,000 mating cycles, without exceeding low-level contact resistance	EIA-364-09B
Environmental Performance	Mechanical Shock	No discontinuities greater than 100 ns, Test Condition A	EIA-364-27A
	Vibration	No discontinuities greater than 100 ns, Test Condition III	EIA-364-28A
	Humidity	10 (24 hour) cycles with connector mated	EIA-364-31A
	Thermal Shock	-55°C to +85°C, 5 (1 hour) cycles	EIA-364-32B
	Mixed Flowing Gas	Environmental Class II for 96 hours with connector unmated	EIA-364-65



**Figure 1 50 Position, Two Row Pin Pattern**

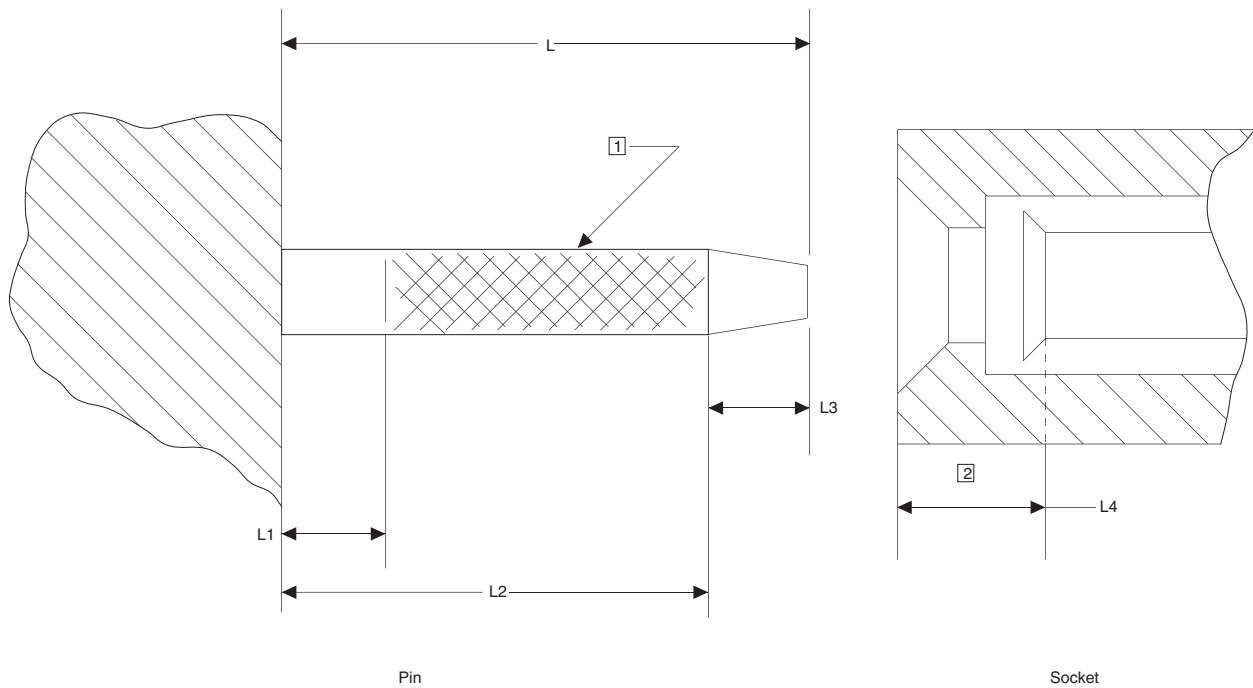
## Appendix CompactFlash Connector Specifications



**Figure 2 Socket Connector Entry**

## Appendix CompactFlash Connector Specifications

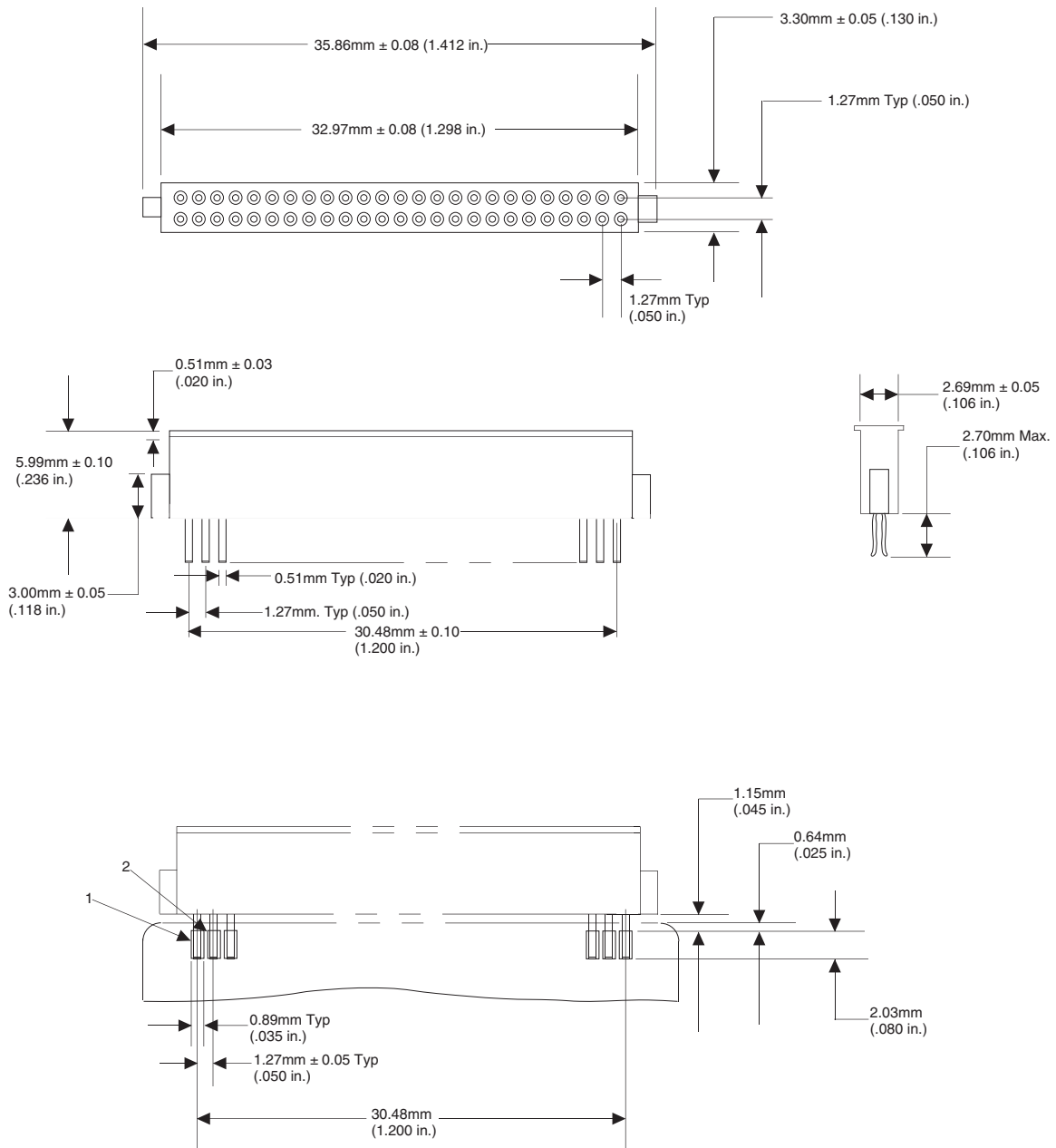
Description	Pin Number	L ± 0.10	L1 Max	L2 Ref	L3 ± 0.10	L4
Power	1, 13, 38 & 50	5.00 [.197]	0.50 [.020]	4.50 [.177]	0.50 [.020]	0.50 - 2.50 [.020 - .098]
General	All other pins	4.25 [.167]	0.50 [.020]	3.75 [.148]	0.50 [.020]	0.50 - 2.50 [.020 - .098]
Detect	25, 26	3.50 [.138]	0.50 [.020]	3.00 [.118]	0.50 [.020]	0.50 - 2.50 [.020 - .098]



- Notes:
- 1 Pin/Socket contact area.
  - 2 L4 is the point of first engagement for mating with the socket contacts/housing mounted within the card.

**Figure 3 Pin and Socket Detail**

# Appendix CompactFlash Connector Specifications

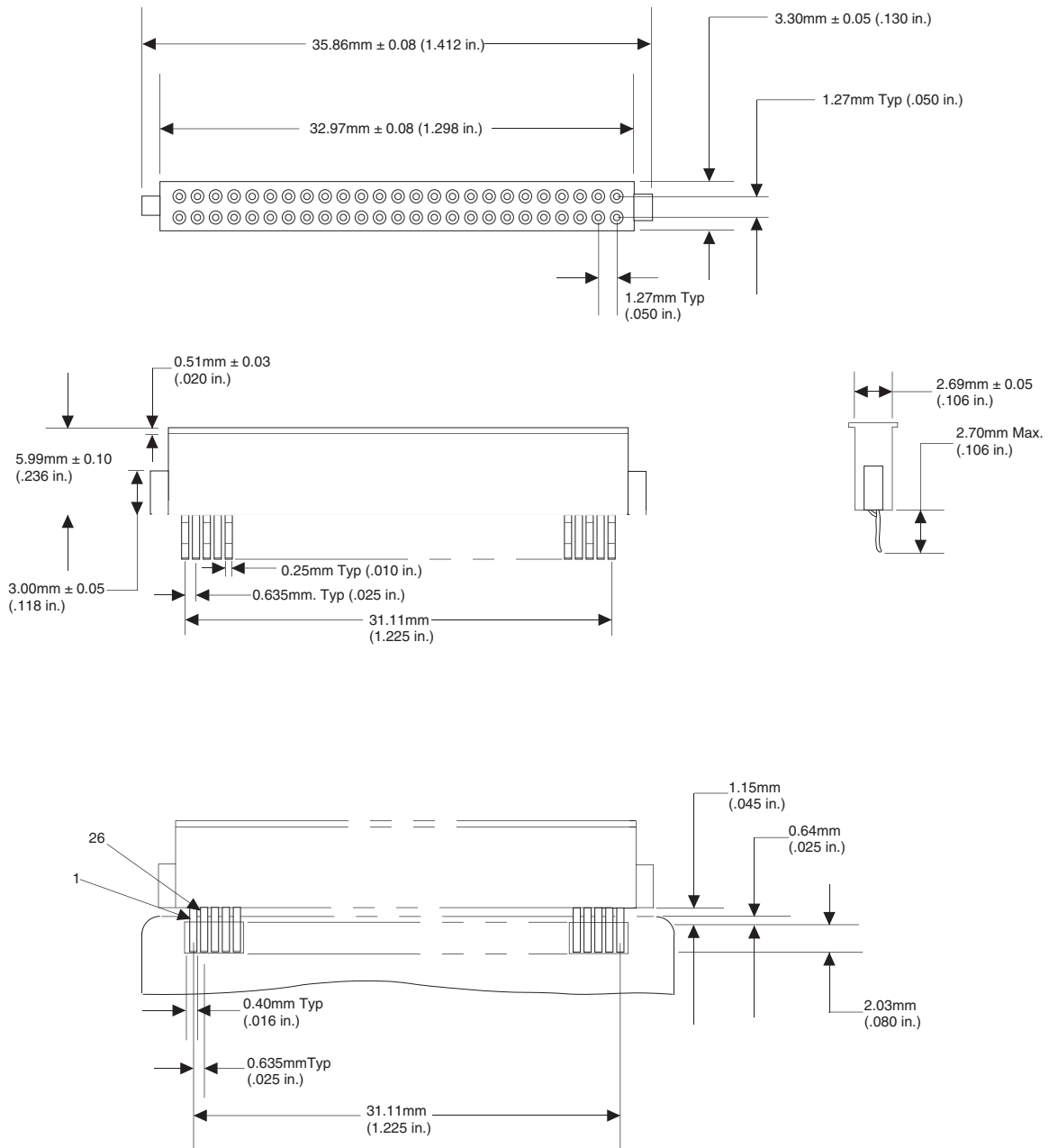


Recommended PCB Pattern

Figure 4 Straddle Mount CF Card Socket



# Appendix CompactFlash Connector Specifications



Recommended PCB Pattern

**Figure 5 Surface Mount CF Card Socket**

## Appendix CompactFlash Connector Specifications

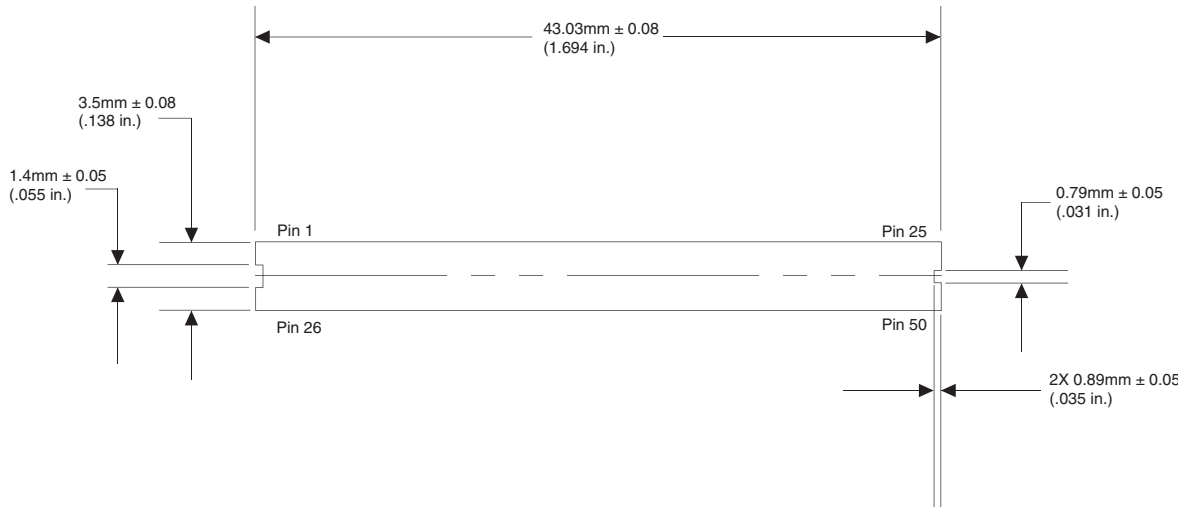


Figure 6 Pin Connector Opening

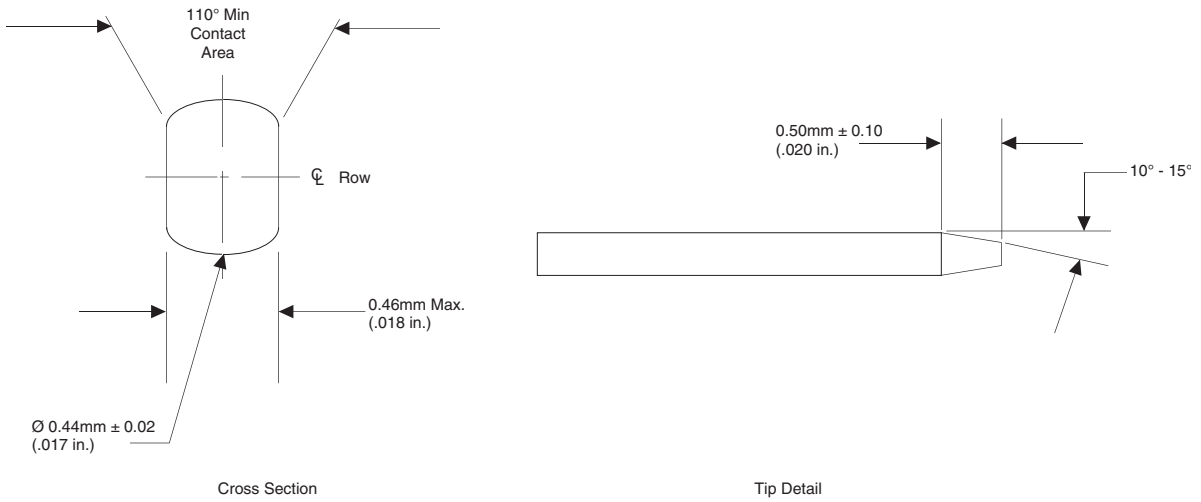
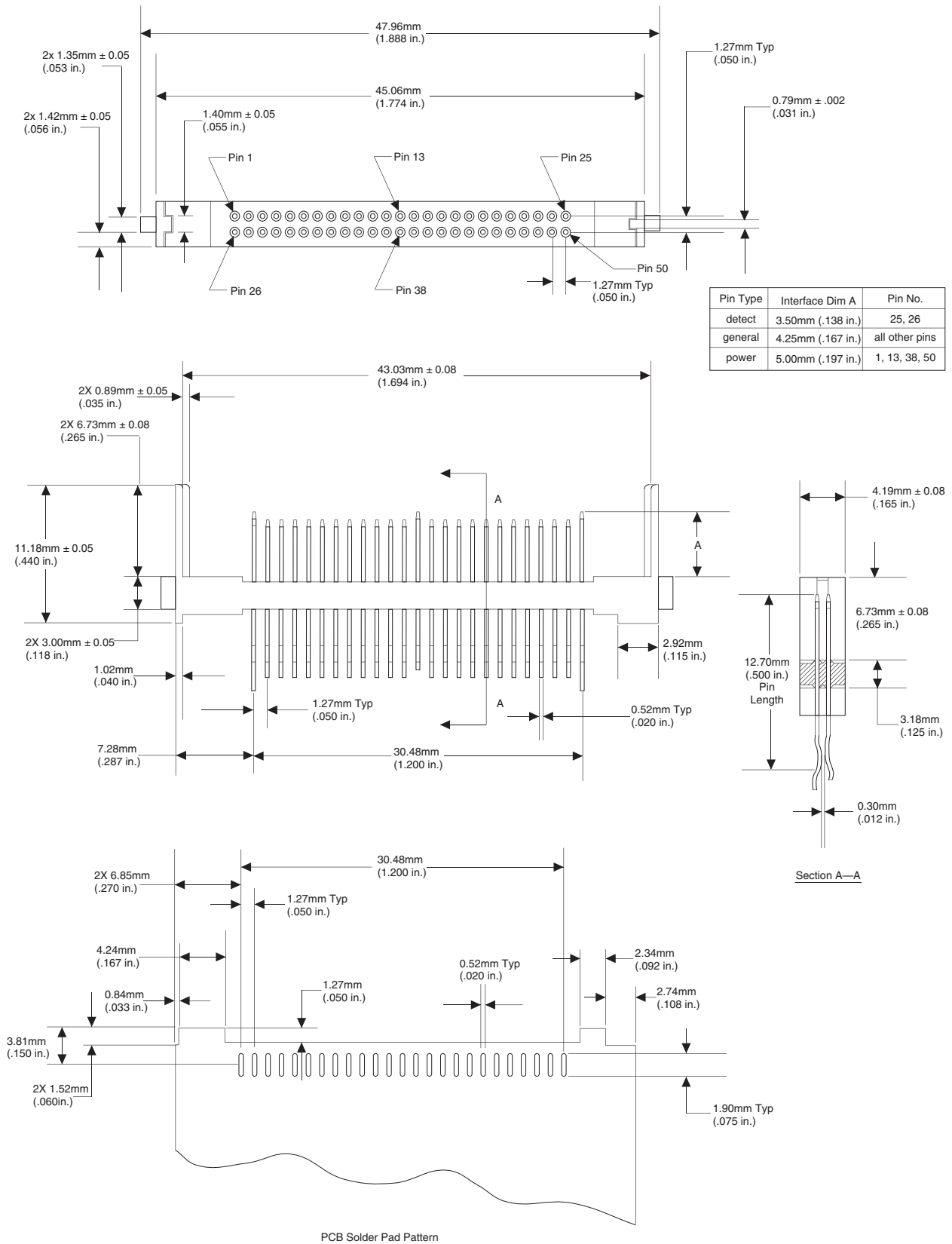


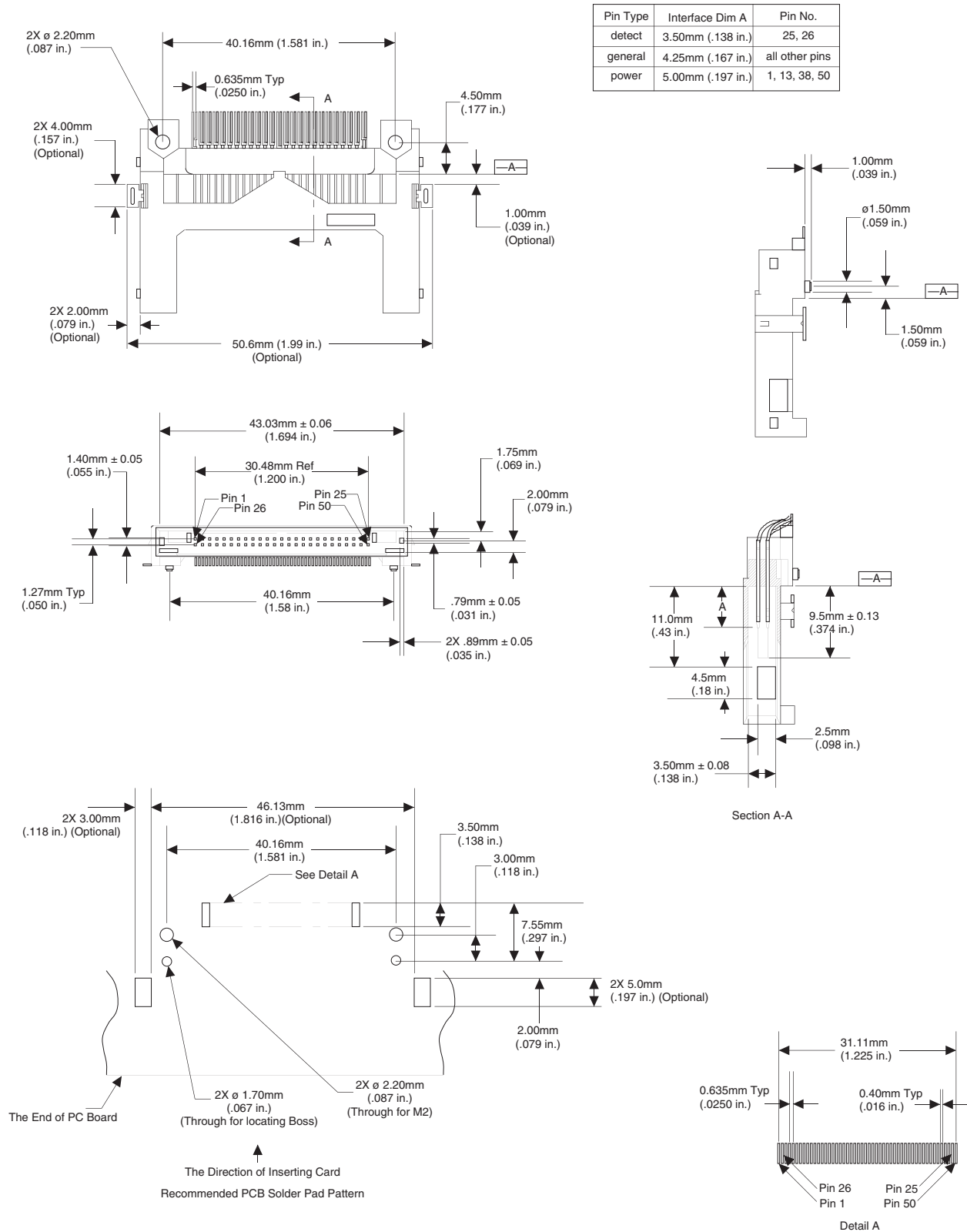
Figure 7 Header Pin Detail

# Appendix CompactFlash Connector Specifications

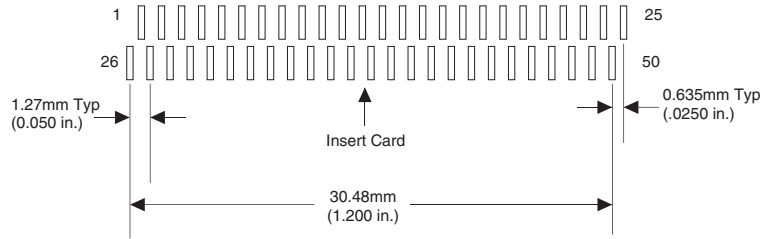


**Figure 8 Straddle Mount CF Card Adapter Header**

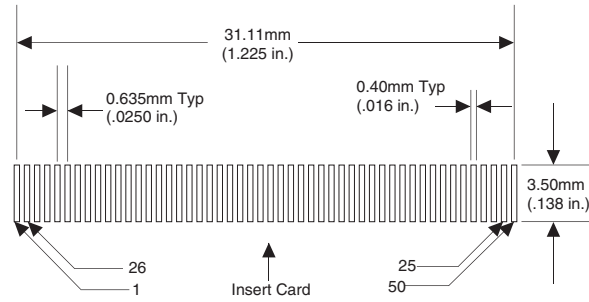
# Appendix CompactFlash Connector Specifications



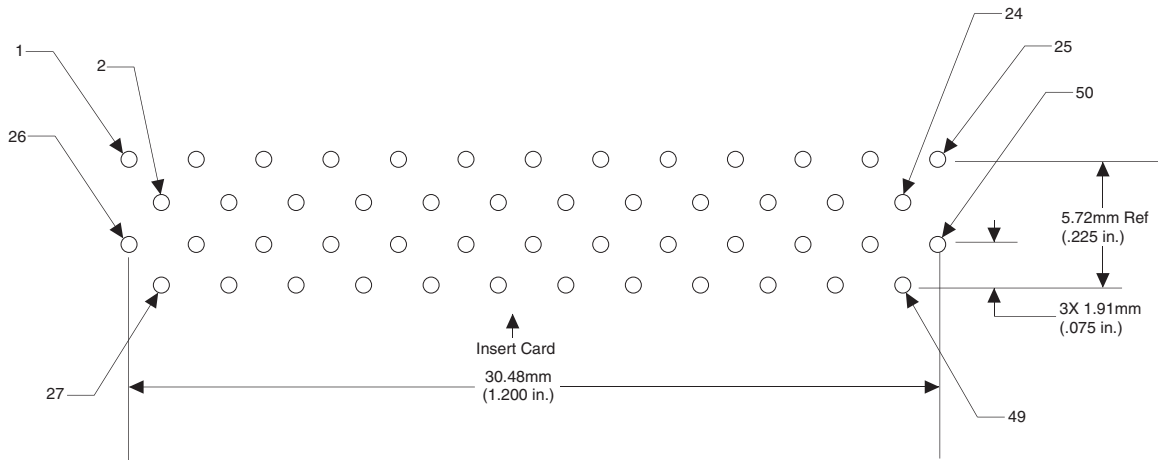
## Appendix CompactFlash Connector Specifications



**Figure 10 Two Row SMT Host PCB Pattern**

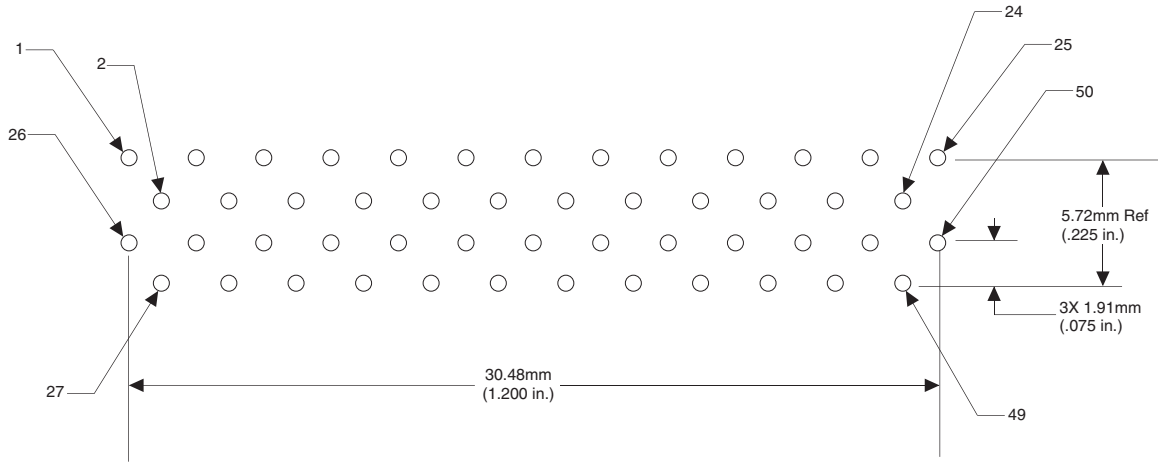


**Figure 11 Single Row SMT Host PCB Pattern**

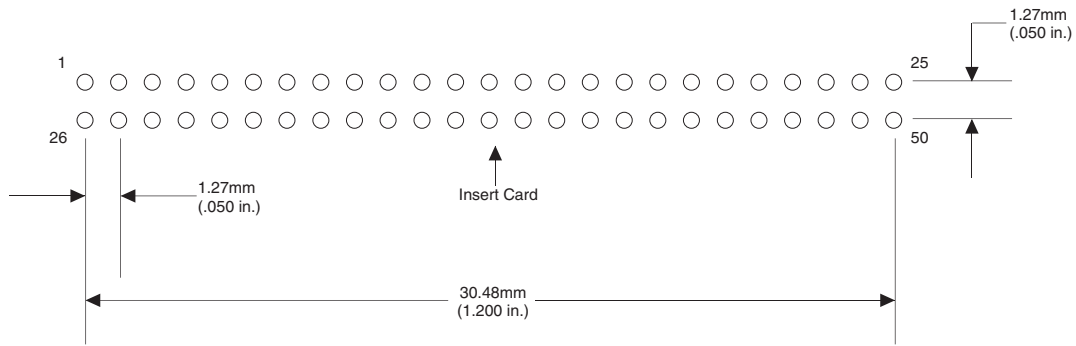


**Figure 12 Right Angle Through Hole Host PCB Pattern**

## Appendix CompactFlash Connector Specifications



**Figure 13 Vertical Through Hole Host PCB Pattern**



**Figure 14 Alternate Right Angle Through Hole Host PCB Pattern**

## **Limited Warranty**

### **I. WARRANTY STATEMENT**

SanDisk warrants its products to be free of any defects in materials or workmanship that would prevent them from functioning properly for one year from the date of purchase. This express warranty is extended by SanDisk Corporation.

### **II. GENERAL PROVISIONS**

This warranty sets forth the full extent of SanDisk's responsibilities regarding the SanDisk CompactFlash Memory Card. In satisfaction of its obligations hereunder, SanDisk, at its sole option, will either repair, replace or refund the purchase price of the product.

NOTWITHSTANDING ANYTHING ELSE IN THIS LIMITED WARRANTY OR OTHERWISE, THE EXPRESS WARRANTIES AND OBLIGATIONS OF SELLER AS SET FORTH IN THIS LIMITED WARRANTY, ARE IN LIEU OF, AND BUYER EXPRESSLY WAIVES ALL OTHER OBLIGATIONS, GUARANTIES AND WARRANTIES OF ANY KIND, WHETHER EXPRESS OR IMPLIED, INCLUDING WITHOUT LIMITATION, ANY IMPLIED WARRANTY OF MERCHANTABILITY OR FITNESS FOR A PARTICULAR PURPOSE OR INFRINGEMENT, TOGETHER WITH ANY LIABILITY OF SELLER UNDER ANY CONTRACT, NEGLIGENCE, STRICT LIABILITY OR OTHER LEGAL OR EQUITABLE THEORY FOR LOSS OF USE, REVENUE, OR PROFIT OR OTHER INCIDENTAL OR CONSEQUENTIAL DAMAGES, INCLUDING WITHOUT LIMITATION PHYSICAL INJURY OR DEATH, PROPERTY DAMAGE, LOST DATA, OR COSTS OF PROCUREMENT OF SUBSTITUTE GOODS, TECHNOLOGY OR SERVICES. IN NO EVENT SHALL THE SELLER BE LIABLE FOR DAMAGES IN EXCESS OF THE PURCHASE PRICE OF THE PRODUCT, ARISING OUT OF THE USE OR INABILITY TO USE SUCH PRODUCT, TO THE FULL EXTENT SUCH MAY BE DISCLAIMED BY LAW.

SanDisk's products are not warranted to operate without failure. Accordingly, in any use of products in life support systems or other applications where failure could cause injury or loss of life, the products should only be incorporated in systems designed with appropriate redundancy, fault tolerant or back-up features.

### **III. WHAT THIS WARRANTY COVERS**

For products found to be defective within one year of purchase, SanDisk will have the option of repairing or replacing the defective product, if the following conditions are met:

- A. A warranty registration card for each defective product was submitted and is on file at SanDisk. If not, a warranty registration card must accompany each returned defective product. This card is included in each product's original retail package.
- B. The defective product is returned to SanDisk for failure analysis as soon as possible after the failure occurs.
- C. An incident card filled out by the user, explaining the conditions of usage and the nature of the failure, accompanies each returned defective product.
- D. No evidence is found of abuse or operation of products not in accordance with the published specifications, or of exceeding storage or maximum ratings or operating conditions.

All failing products returned to SanDisk under the provisions of this limited warranty shall be tested to the product's functional and performance specifications. Upon confirmation of failure, each product will be analyzed, by whatever means necessary, to determine the root cause of failure. If the root cause of failure is found to be not covered by the above provisions, then the product will be returned to the customer with a report indicating why the failure was not covered under the warranty.

This warranty does not cover defects, malfunctions, performance failures or damages to the unit resulting from use in other than its normal and customary manner, misuse, accident or neglect; or improper alterations or repairs.

SanDisk reserves the right to repair or replace, at its discretion, any product returned by its customers, even if such product is not covered under warranty, but is under no obligation to do so.

SanDisk may, at its discretion, ship repaired or rebuilt products identified in the same way as new products, provided such cards meet or exceed the same published specifications as new products. Concurrently, SanDisk also reserves the right to market any products, whether new, repaired, or rebuilt, under different specifications and product designations if such products do not meet the original product's specifications.

## **Limited Warranty**

### **IV. RECEIVING WARRANTY SERVICE**

According to SanDisk's warranty procedure, defective product should be returned only with prior authorization from SanDisk Corporation. Please contact SanDisk's Customer Service department at 408-542-0595 with the following information: product model number and description, serial numbers, nature of defect, conditions of use, proof of purchase and purchase date. If approved, SanDisk will issue a Return Material Authorization or Product Repair Authorization number. Ship the defective product to:

SanDisk Corporation  
Attn: RMA Returns  
(Reference RMA or PRA #)  
140 Caspian Court  
Sunnyvale, CA 94089

### **V. STATE LAW RIGHTS**

SOME STATES DO NOT ALLOW THE EXCLUSION OR LIMITATION OF INCIDENTAL OR CONSEQUENTIAL DAMAGES, OR LIMITATION ON HOW LONG AN IMPLIED WARRANTY LASTS, SO THE ABOVE LIMITATIONS OR EXCLUSIONS MAY NOT APPLY TO YOU. This warranty gives you specific rights and you may also have other rights that vary from state to state.

### **VI. OUT OF WARRANTY REPAIRS**

Please contact SanDisk Customer Service at 408-542-0595 for the current out of warranty and repair price list.