

SDM2F200G/GA06GC

Fast Soft Recovery Diode Module

General Description

FRD module devices are optimized to reduce losses and EMI/RFI in high frequency power conditioning electrical systems.

These diode modules are ideally suited for power converters, motors drives and other applications where switching losses are significant portion of the total losses

Features

- Repetitive Reverse Voltage : $V_{RRM} = 600V$
- Low Forward Voltage Drop : $V_F(\text{typ.}) = 1.2V$
- Average Forward Current : $I_F(\text{AV.}) = 200A$ @ $T_C = 100^\circ C$
- Fast Reverse Recovery Time : $t_{rr}(\text{typ.}) = 110 \text{ ns}$ @ 200A
- Extensive Characterization of Recovery Parameters
- Reduced EMI and RFI
- Isolation Type Package

Applications

- High Speed & High Power Converters, Welders.
- Various Switching and Telecommunication Power Supply.

Absolute Maximum Ratings @ $T_C=25^\circ C$ (Per Leg)

Symbol	Parameter	Value	Unit
V_{RRM}	Repetitive Peak Reverse Voltage	600	V
V_R	Reverse DC Voltage	480	V
$I_{F(AV)}$	Average Forward Current	$T_C = 100^\circ C$, Per Diode	200
		$T_C = 100^\circ C$, Per Module	400
I_{FSM}	No Repetitive Surge Forward Current (1/2 cycle, sine)	3300	A
I^2t	I^2t For Fusing (60Hz, sine, $t=8.3\text{ms}$, $T_J = 25^\circ C$)	$45.0 * 10^3$	A ² s
P_D	Maximum Power Dissipation	540	W
T_J	Junction Temperature	-40 to +150	$^\circ C$
T_{STG}	Storage Temperature	-40 to +150	$^\circ C$
V_{ISOL}	Isolation Voltage (@ AC 1minutes)	2500	V

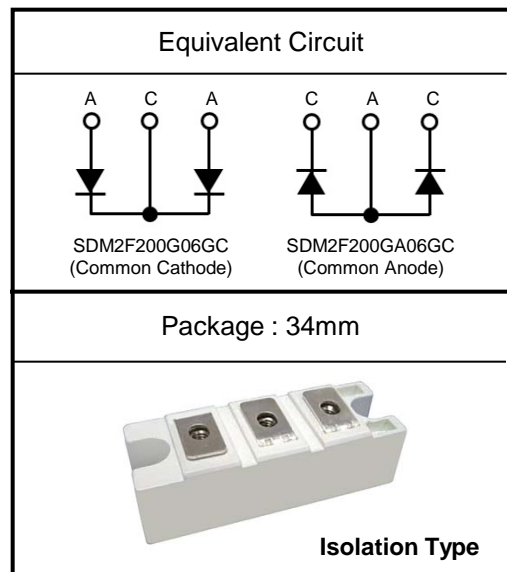

Please see the package Out line information

Electrical Characteristics $T_C=25^\circ\text{C}$ unless otherwise specified

Symbol	Parameter	Test Conditions	Min	Typ	Max	Unit	
V_R	Cathode Anode Breakdown Voltage	$I_R = 100\mu\text{A}$	600	--	--	V	
I_R	Repetitive Peak Reverse Current	$V_R = 600\text{V}, T_C = 100^\circ\text{C}$	--	--	1	mA	
V_{FM}	Maximum Forward Voltage	$I_F = 200\text{A}$	$T_C = 25^\circ\text{C}$	--	1.2	1.45	V
			$T_C = 100^\circ\text{C}$	--	1.1	--	
t_{rr}	Reverse Recovery Time	$V_R = 30\text{V},$ $I_F = 1\text{A},$ $di/dt = -400\text{A}/\mu\text{s}$	$T_C = 25^\circ\text{C}$	--	45	60	ns
t_{rr}	Reverse Recovery Time	$V_R = 300\text{V},$ $I_F = 200\text{A},$ $di/dt = -400\text{A}/\mu\text{s}$	$T_C = 25^\circ\text{C}$	--	110	--	ns
			$T_C = 100^\circ\text{C}$	--	180	--	

Thermal Mechanical Specifications

Symbol	Parameter	Test Conditions	Min	Typ	Max	Unit
$R_{\theta JC}$	Thermal Resistance(Isolation)	Junction-to-Case	--	--	0.23	$^\circ\text{C}/\text{W}$
-	Torque	Mounting Torque (M6)	4.0			N·m
-	Torque	Terminal Torque (M6)	3.0			N·m
L x W x H	Dimensions	Typical, see outline drawing	94 x 34 x 29			mm
-		Term. To Term	--	23	--	mm
m	Mass		--	180	--	g

Characterization curves

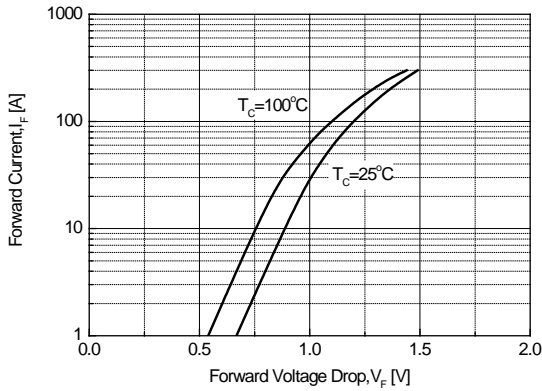

Figure 1. Typical Forward Voltage Drop vs. Instantaneous Forward Current

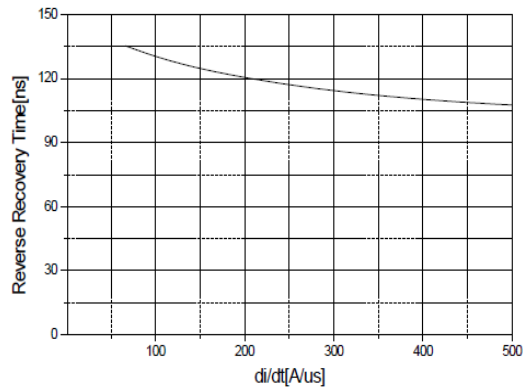

Figure 2. Typical Reverse Recovery Time vs. $-di/dt$

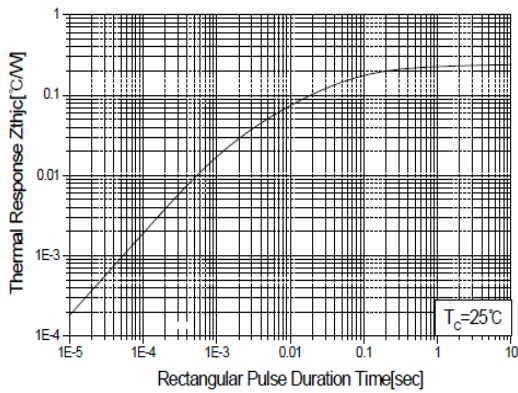

Figure 3. Transient Thermal Impedance (Z_{thjc}) Characteristics

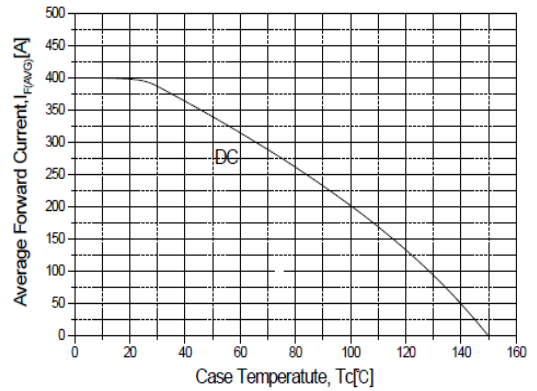

Figure 4. Forward Current Derating Curve

Package Out line Information

34mm



Dimensions in mm

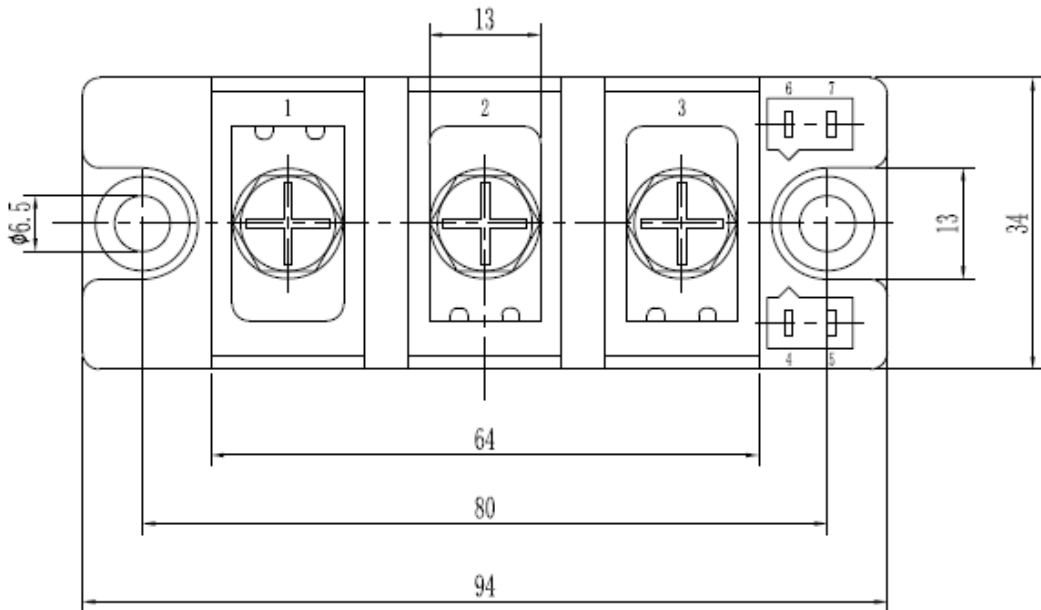
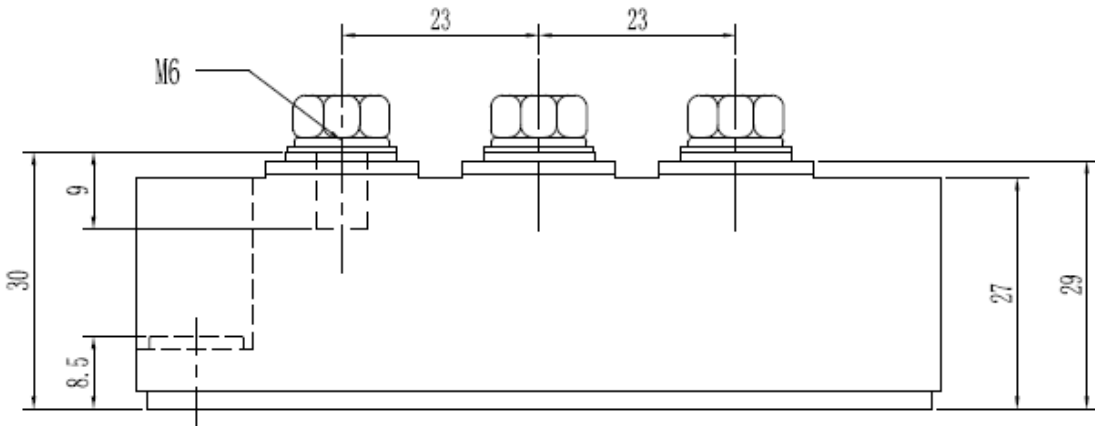

Attached (recommended torque):

Mounting torque(M6) 4.0 Nm Terminal torque(M6) 3.0 Nm