

Silicon Carbide Power Schottky Diode

Features:

- Positive Temperature Coefficient for Ease of Paralleling
- Temperature Independent Switching Behavior
- 175 °C Maximum Operating Temperature
- Zero Reverse Recovery Current
- Zero Forward Recovery Voltage

Product Summary		
V_{DC}	1200	V
I_F	10	A
Q_c	39	nC

Applications:

- Solar Inverter
- SMPS
- Power Factor Correction
- Induction Heating
- UPS
- Motor Drive

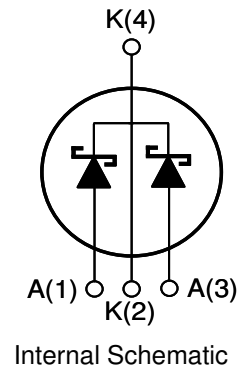
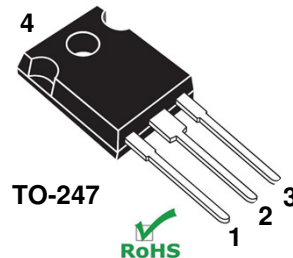

MAXIMUM RATINGS

Parameter	Symbol	Conditions	Value	Unit
Repetitive Peak Reverse Voltage	V_{RRM}	$T_j = 25\text{ °C}$	1200	V
DC Blocking Voltage	V_{DC}		1200	
Continuous Forward Current (Per Leg / Per Device)	I_F	$T_C < 160\text{ °C}$	5 / 10	A
		$T_C < 100\text{ °C}$	10 / 20	
Peak Repetitive Forward Current (Per Leg / Per Device)	I_{FRM}	$T_C = 125\text{ °C}, D = 0.1$	20 / 50	
Non-Repetitive Forward Surge Current (Per Leg / Per Device)	I_{FSM}	$T_C = 25\text{ °C}, t_P = 10\text{ ms}$	26 / 52	
Power Dissipation (Per Leg / Per Device)	P_{TOT}	$T_C = 25\text{ °C}$	75 / 150	W
Operating and Storage Temperature	T_j, T_{stg}		-55 to +175	°C

THERMAL CHARACTERISTICS

Parameter	Symbol	Conditions	Value			Unit
			Min	Typ	Max	
Thermal Resistance, junction-case	R_{thJC}	Per Leg	-	1.54	-	°C / W
		Both Legs	-	0.77	-	
Thermal Resistance, junction-ambient	R_{thJA}		-	62	-	

ELECTRICAL CHARACTERISTICS (Per Leg), at $T_j = 25\text{ C}$ unless otherwise stated

Parameter	Symbol	Conditions	Value			Unit
			Min	Typ	Max	
Forward Voltage	V_F	$I_F = 5\text{ A}, T_j = 25\text{ °C}$	-	1.6	1.8	V
		$I_F = 5\text{ A}, T_j = 150\text{ °C}$	-	2.2	2.5	
Reverse Current	I_R	$V_R = 1200\text{ V}, T_j = 25\text{ °C}$	-	5	50	uA
		$V_R = 1200\text{ V}, T_j = 150\text{ °C}$	-	100	-	
Total Capacitive Charge	Q_C	$V_R = 400\text{ V}, I_F = 5\text{ A}, di/dt = 500\text{A/us}$	-	20	-	nC
Total Capacitance	C	$V_R = 1\text{ V}, f = 100\text{kHz}$	-	577	-	pF
		$V_R = 300\text{ V}, f = 100\text{kHz}$	-	24	-	
		$V_R = 600\text{ V}, f = 100\text{KHz}$	-	17	-	

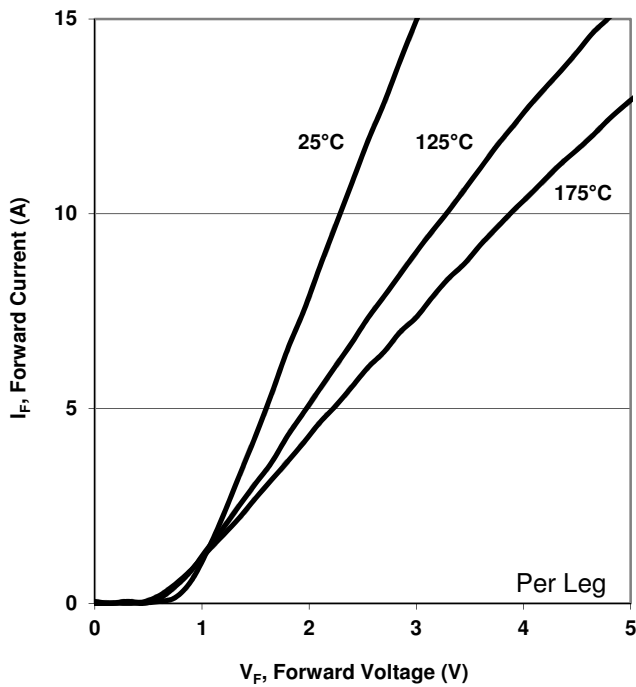

Figure 1. Typ. Forward Characteristics
 $I_F = f(V_F)$; parameter: T_j

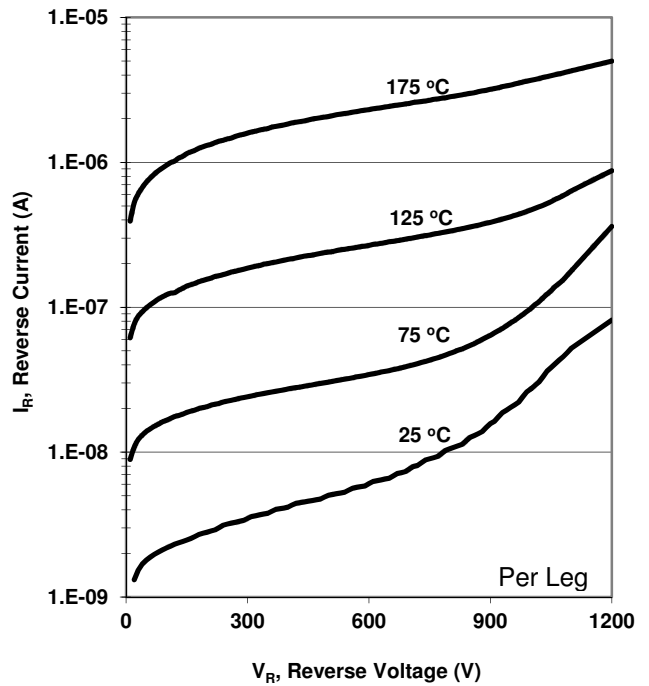

Figure 2. Typ. Reverse Characteristics
 $I_R = f(V_R)$

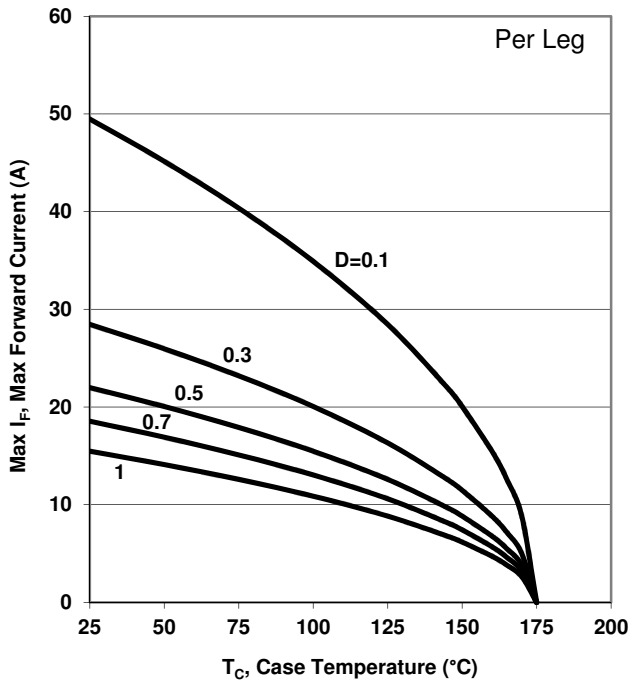

Figure 3. Max Forward Current
 $I_F = f(T_C); T_j < 175\text{ }^\circ\text{C}; R_{th,Jc(max)}$

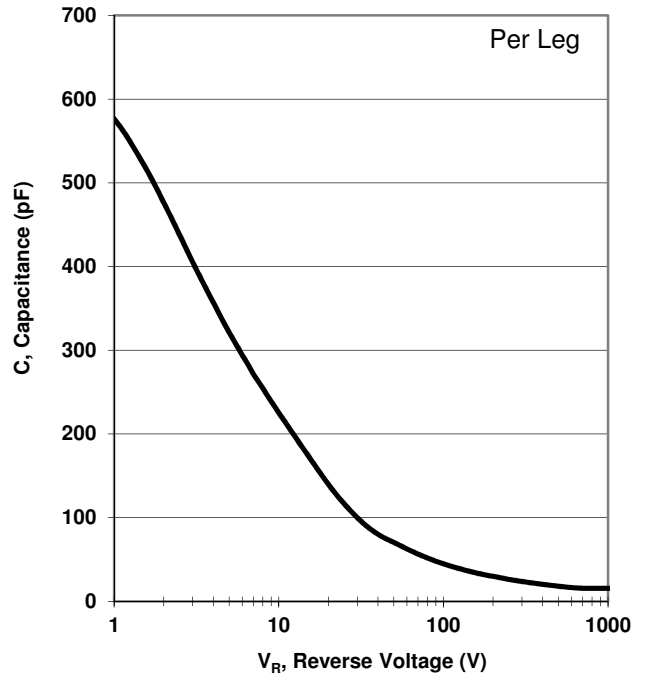

Figure 4. Typ. Capacitance vs. Reverse Voltage
 $C = f(V_R); T_C = 25\text{ }^\circ\text{C}; f = 1\text{ MHz}$

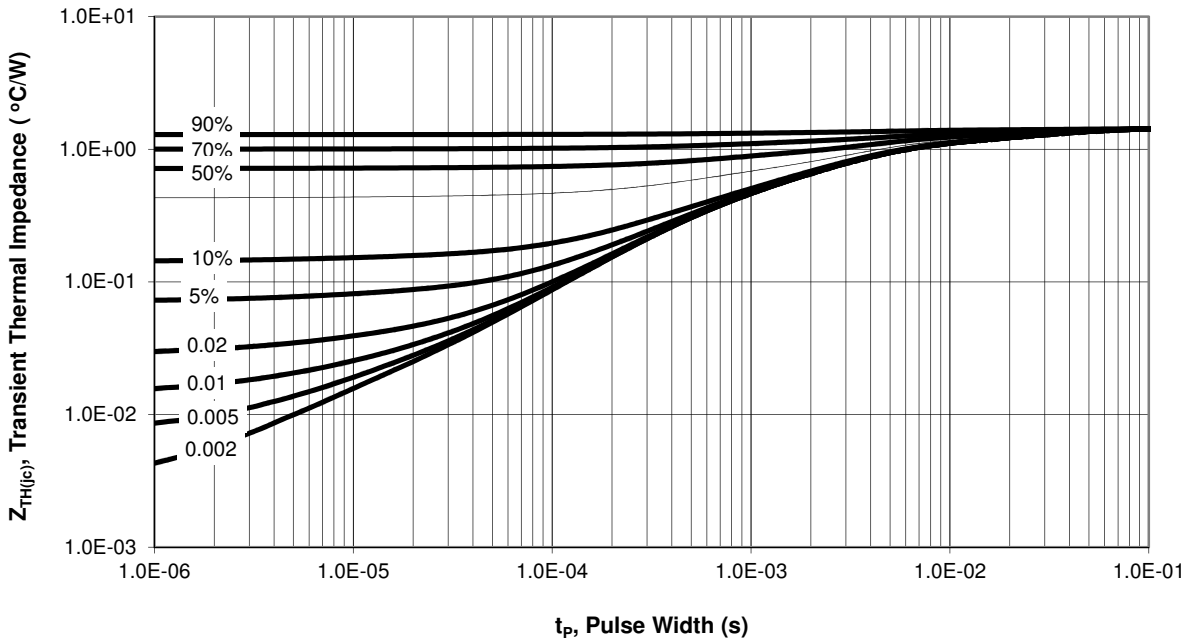
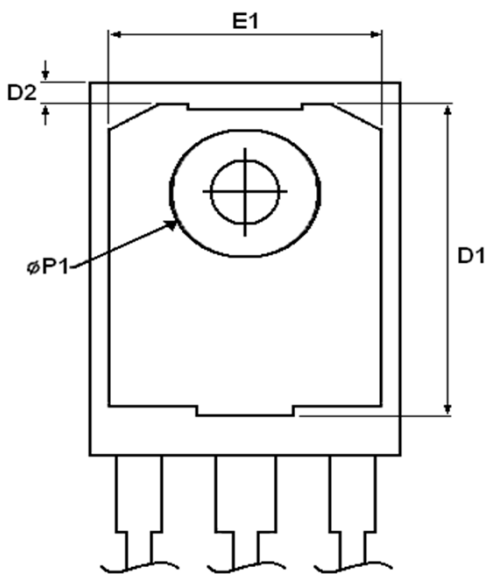
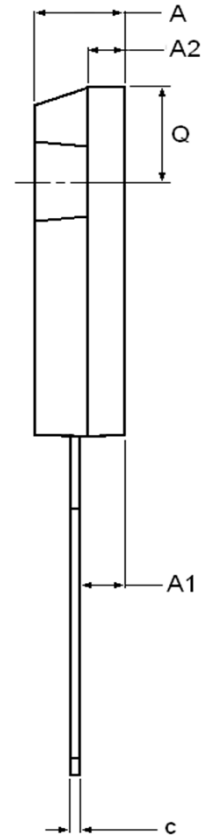
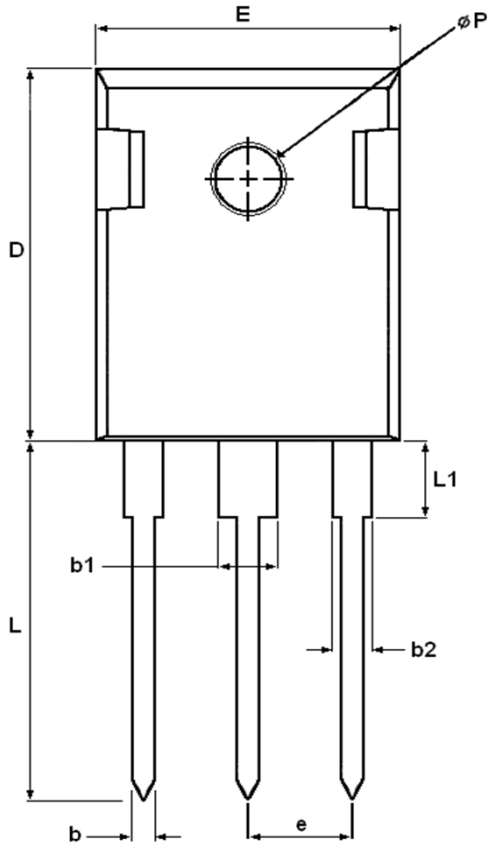

Figure 5. Transient Thermal Impedance
 $Z_{th(jc)} = f(t_p); \text{parameter: Duty Ratio}$

Package Dimensions: TO-247



DIM	MILLIMETERS		INCHES	
	MIN	MAX	MIN	MAX
A	4.903	5.157	0.193	0.203
A1	2.273	2.527	0.090	0.100
A2	1.853	2.108	0.073	0.083
b	1.073	1.327	0.042	0.052
b1	2.873	3.381	0.113	0.133
b2	1.903	2.386	0.042	0.052
c	0.600	0.752	0.024	0.029
D	20.823	21.077	0.820	0.830
D1	17.393	17.647	0.685	0.695
D2	1.063	1.317	0.042	0.052
e	5.450		0.215	
E	15.773	16.027	0.621	0.631
E1	13.893	14.147	0.547	0.557
L	20.053	20.307	0.789	0.799
L1	4.168	4.472	0.165	0.175
Q	6.043	6.297	0.238	0.248
ØP	3.560	3.660	0.140	0.144
ØP1	7.063	7.317	0.278	0.288

Published by
SemiSouth Laboratories, Inc.
201 Research Boulevard
Starkville, MS 39759 USA
© SemiSouth Laboratories, Inc. 2011

Information in this document supersedes and replaces all information previously supplied.

Information in this document is provided solely in connection with SemiSouth products. SemiSouth Laboratories, Inc. reserves the right to make changes, corrections, modifications or improvements, to this document without notice.

No license, express or implied to any intellectual property rights is granted under this document.

Unless expressly approved in writing by an authorized representative of SemiSouth, SemiSouth products are not designed, authorized or warranted for use in military, aircraft, space, life saving, or life sustaining applications, nor in products or systems where failure or malfunction may result in personal injury, death, or property or environmental damage.