

## General Description

The SDP339 series is consisted by four independent precision voltage comparators. The input common mode voltage range of these comparators includes ground, even when operated from a single power supply voltage. The SDP339 series is designed to directly interface with TTL and CMOS. It can be widely used in such applications as battery charger, cordless telephone, switching power supply, DC-DC module and PC motherboard.

The SDP339 series are available in 2 Packages: DIP-14 and SOP-14.

## Features

- Wide Supply Voltage Range  
Single Supply: 2.0V to 18V  
Dual Supplies:  $\pm 1.0V$  to  $\pm 9V$
- Very Low Supply Current Drain: 0.45mA(Typical)
- Low Input Bias Current: 25nA (Typical)
- Low Input Offset Current:  $\pm 5nA$  (Typical)
- Low Input Offset Voltage:  $\pm 2mV$  (Typical)
- Input Common Mode Voltage Range Includes Ground
- Differential Input Voltage Range Equals to the Power Supply Voltage
- Low Output Saturation Voltage:100mV at 4mA

## Applications

- Battery Charger
- Cordless Telephone
- Switching Power Supply
- DC-DC Module
- PC Motherboard
- Communication Equipment

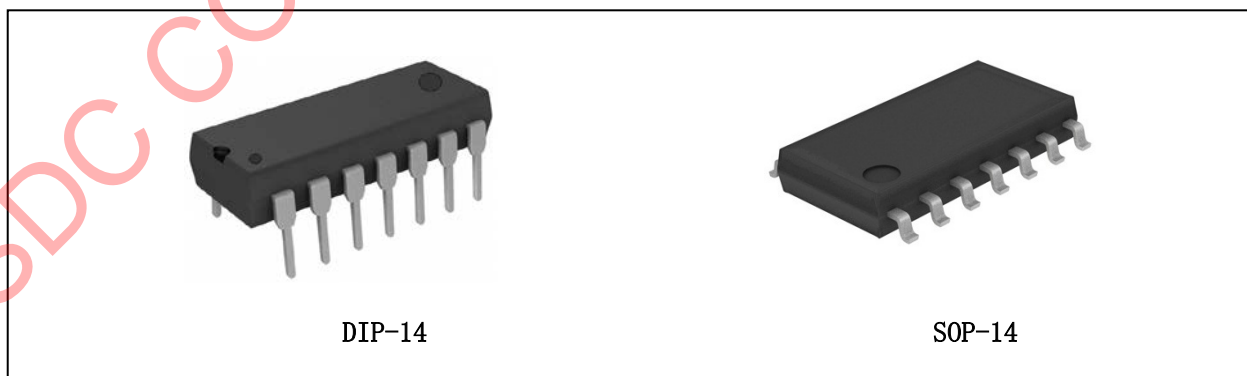


Figure 1. Package Type

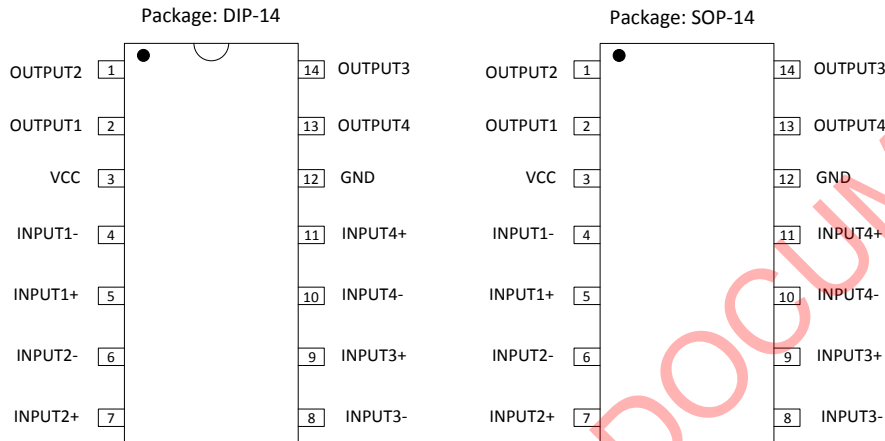
**Pin Configuration**


Figure 2. Pin Configuration

Pin Number	Pin Name	Function
1, 2, 13, 14	OUT	Output pins of Comparator
4, 6, 8, 10	INPUT-	Input- pins of Comparator
5, 7, 9, 11	INPUT+	Input+ pins of Comparator
3	VCC	VCC of Comparator
12	GND	GND of Comparator

Table1. Pin Description

Functional Block Diagram

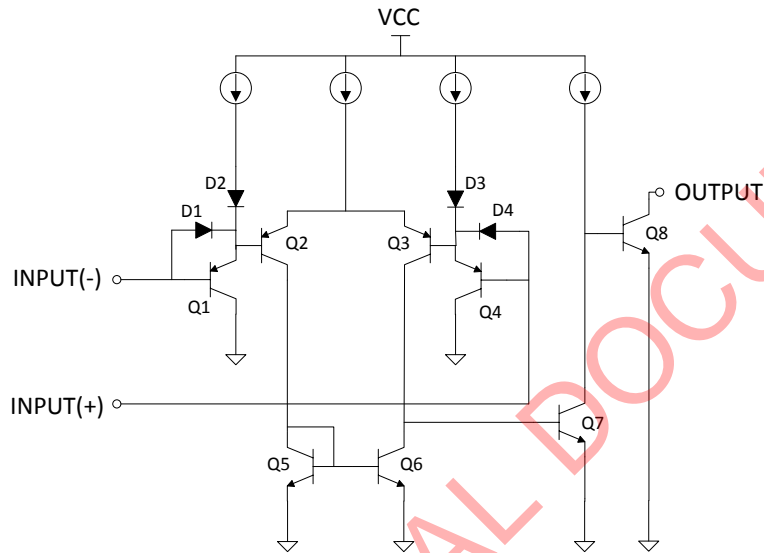
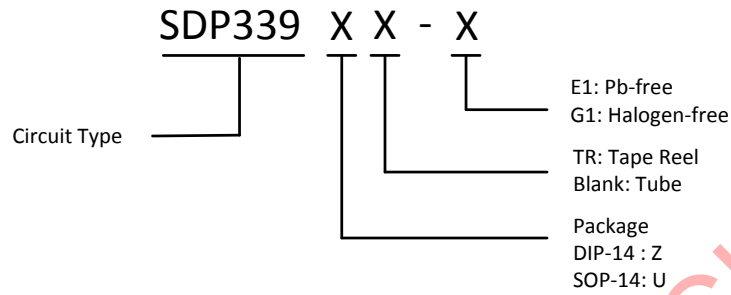


Figure 4. Functional Block Diagram

**Ordering Information**


Package	Temperature Range	Part Number		Marking ID		Packing Type
		Pb-free	Halogen-free	Pb-free	Halogen-free	
SOP-14	-40°C ~85°C	SDP339UTR-E1	SDP339UTR-G1	SDP339	SDP339G	Tape Reel
DIP-14		SDP339Z-E1	SDP339Z-G1	SDP339	SDP339G	Tube

SDC CONFIDENTIAL DOCUMENT

**Absolute Maximum Ratings** (Note: Stresses greater than those listed under absolute maximum ratings may cause permanent damage to the device.)

Parameter	Symbol	Value	Unit	
Supply Voltage	$V_{CC}$	20	V	
Differential Input Voltage	$V_{ID}$	20	V	
Input Voltage	$V_{IN}$	-0.3~ 20	V	
Input Current	$I_{IN}$	50	mA	
Output Short Circuit to Ground		Continuous		
Power Dissipation ( $T_a=25^\circ\text{C}$ )	$P_D$	DIP-14	1050	mW
		SOP-14	830	
Operating Junction Temperature	$T_J$	150	$^\circ\text{C}$	
Storage Temperature Range	$T_{STG}$	-65~150	$^\circ\text{C}$	
Latch-up test per JEDEC 78	-	200	mA	

Table 2. Absolute Maximum Ratings

**Recommended Operating Conditions**

Parameter	Symbol	Min	Max	Unit
Power supply	$V_{CC}$	2	18	V
Operation temperature	$T_A$	-40	85	$^\circ\text{C}$

Table 3 Recommended Operating Conditions

**Electrical Characteristics** (Ta=25°C, V<sub>CC</sub>=5V, unless otherwise specified)

Parameter	Symbol	Conditions	Min	Typ	Max	Unit	
Input Offset Voltage	V <sub>IO</sub>	V <sub>OUT</sub> =1.4V, R <sub>S</sub> :0Ω	-	2.0	5.0	mV	
Input Bias Current	I <sub>B</sub>	I <sub>IN+</sub> or I <sub>IN-</sub> with output in Linear Range, I <sub>B</sub> =(I <sub>IN+</sub> + I <sub>IN-</sub> )/2, V <sub>CM</sub> =0V	-	25	250	nA	
Input Offset Current	I <sub>IO</sub>	I <sub>IN+</sub> - I <sub>IN-</sub> , V <sub>CM</sub> =0V	-	5.0	50	nA	
Input Common Mode Voltage Range	V <sub>ICM</sub>	V <sub>CC</sub> =18V	0	-	V <sub>CC</sub> -1.5	V	
Supply Current	I <sub>CC</sub>	R <sub>L</sub> =∞	V <sub>CC</sub> =5V	-	0.45	0.8	mA
			V <sub>CC</sub> =18V	-	0.55	1.0	
Voltage Gain	GV	R <sub>L</sub> ≥15kΩ, V <sub>CC</sub> =18V, V <sub>OUT</sub> =1V to 11V	50	200	-	V/mV	
Large Signal Response Time	T <sub>RES</sub>	V <sub>IN</sub> =TTL Logic swing, V <sub>REF</sub> =1.4V, V <sub>RL</sub> =5V, R <sub>L</sub> =5.1kΩ	-	170	-	ns	
Response Time	T <sub>RES</sub>	V <sub>RL</sub> =5V, R <sub>L</sub> =5.1kΩ	-	0.6	-	us	
Output Sink Current	I <sub>SINK</sub>	V <sub>IN-</sub> =1V, V <sub>IN+</sub> =0, V <sub>OUT</sub> =1.5V	8	20	-	mA	
Saturation Voltage	V <sub>SAT</sub>	V <sub>IN-</sub> =1V, V <sub>IN+</sub> =0, I <sub>SINK</sub> ≤ 4mA	-	100	200	mV	
Output Leakage Current	I <sub>LEAK</sub>	V <sub>IN-</sub> =0V, V <sub>IN+</sub> =1V, V <sub>OUT</sub> =5V	-	0.1	1	nA	

Table 4. Electrical Characteristics

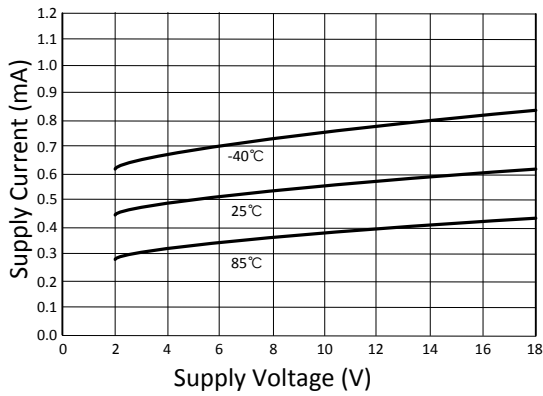
**Typical Performance Characteristics**


Figure 4. Supply Voltage vs. Supply Current

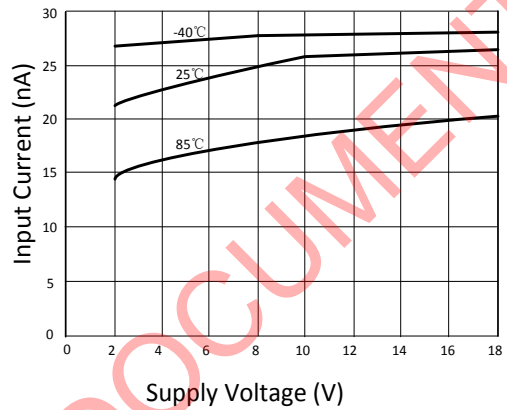


Figure 5. Supply Voltage vs. Input Current

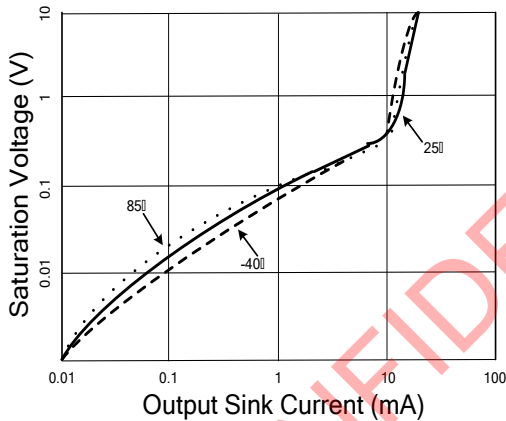


Figure 6. Output Sink Current vs. Saturation Voltage

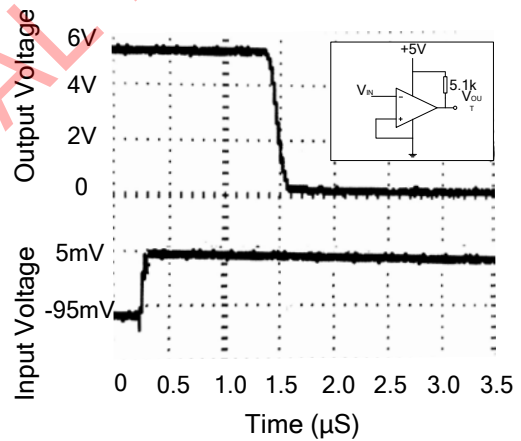


Figure 7. Response Time for 5mV Input Overdrive - Negative Transition

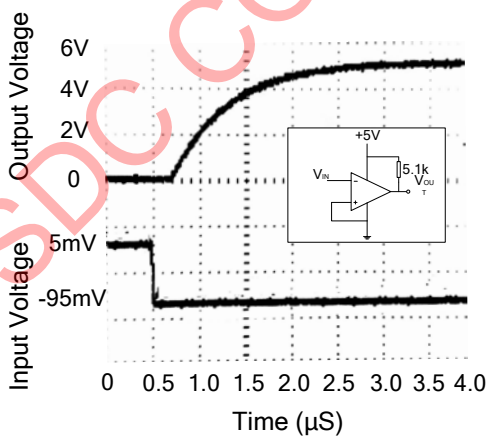


Figure 8. Response Time for 5mV Input Overdrive - Positive Transition

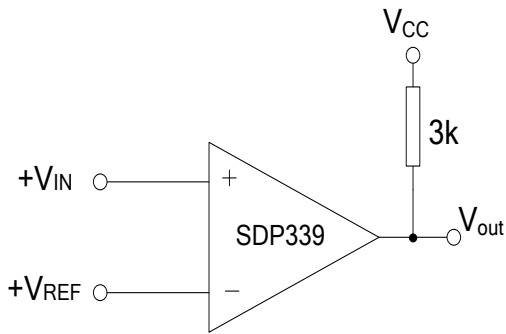
**Typical Applications**


Figure 9. Basic Comparator

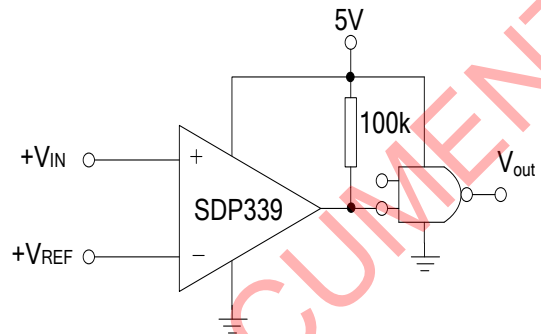


Figure 10. Driving CMOS/TTL

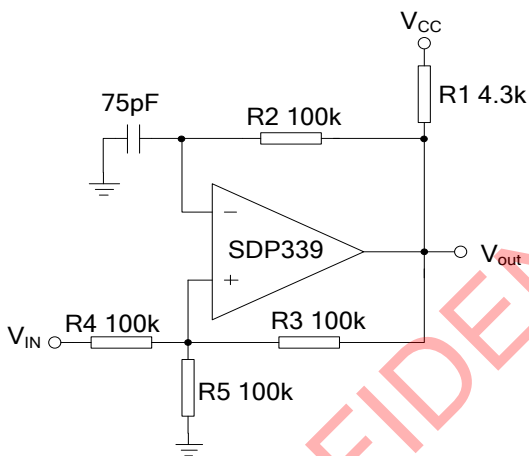


Figure 11. Square wave Oscillator

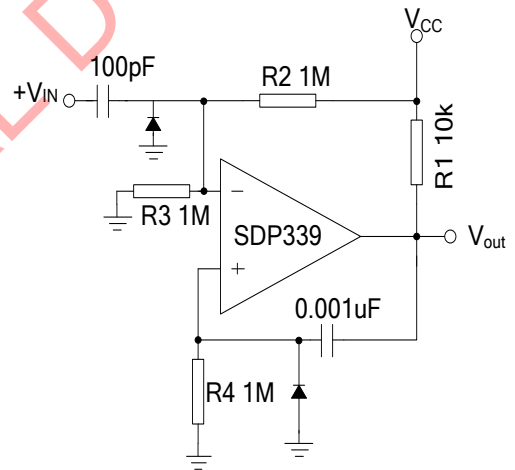
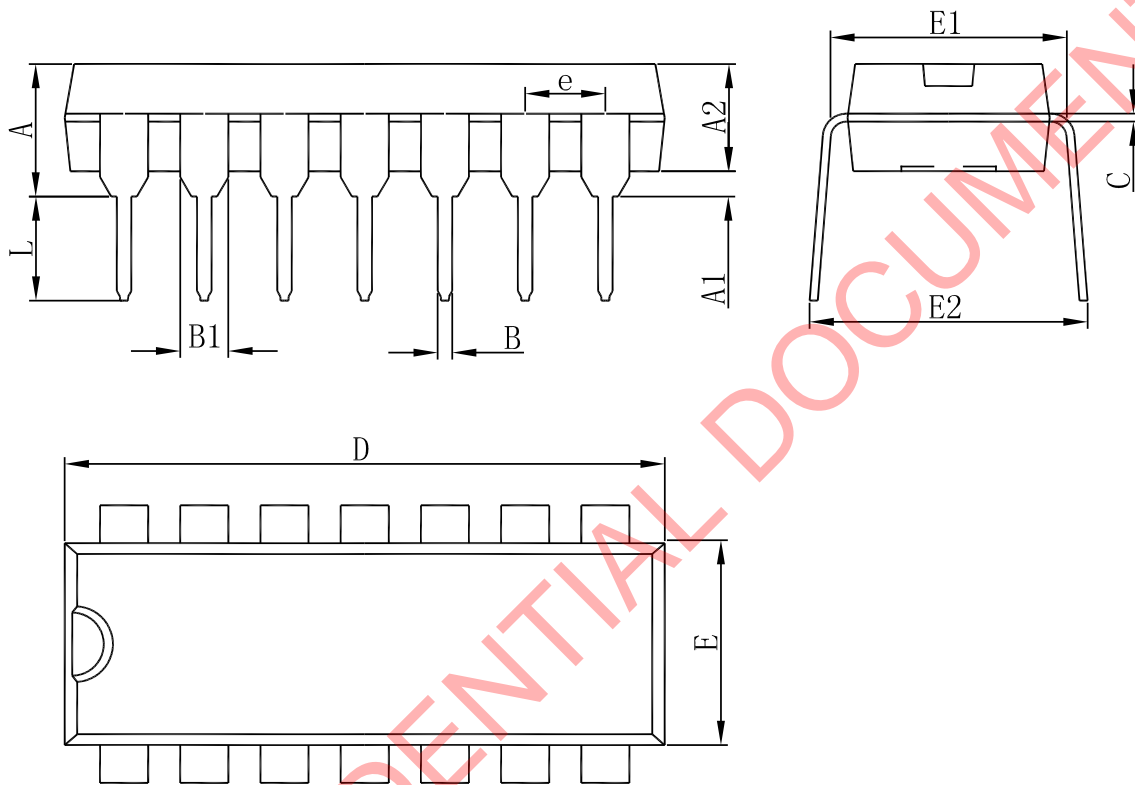
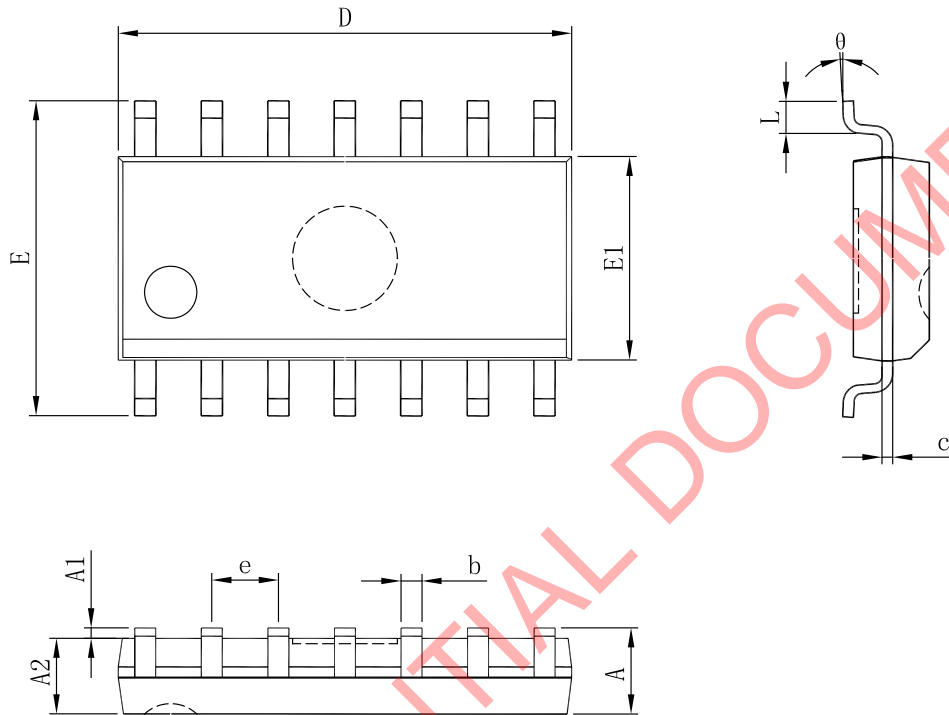


Figure 12. One Shot Multivibrator



**Package Dimensions**
**DIP-14**


Symbol	Dimensions In Millimeters		Dimensions In Inches	
	Min	Max	Min	Max
A	3.710	4.310	0.146	0.170
A1	0.510	-	0.020	-
A2	3.200	3.600	0.126	0.142
B	0.380	0.570	0.015	0.022
B1	1.524 (BSC)		0.060 (BSC)	
C	0.204	0.360	0.008	0.014
D	18.800	19.200	0.740	0.756
E	6.200	6.600	0.244	0.260
E1	7.320	7.920	0.288	0.312
e	2.540 (BSC)		0.100 (BSC)	
L	3.000	3.600	0.118	0.142
E2	8.400	9.000	0.331	0.354

**SOP-14**


Symbol	Dimensions In Millimeters		Dimensions In Inches	
	Min	Max	Min	Max
A	-	1.750	-	0.069
A1	0.100	0.250	0.004	0.010
A2	1.250	-	0.049	-
b	0.310	0.510	0.012	0.020
c	0.100	0.250	0.004	0.010
D	8.450	8.850	0.333	0.348
e	1.270 (BSC)		0.050 (BSC)	
E	5.800	6.200	0.228	0.244
E1	3.800	4.000	0.150	0.157
L	0.400	1.270	0.016	0.050
$\theta$	0°	8°	0°	8°



Shaoxing Devechip Microelectronics Co., Ltd.

<http://www.sdc-semi.com/>

#### IMPORTANT NOTICE

Information in this document is provided solely in connection with Shaoxing Devechip Microelectronics Co., Ltd. (abbr. SDC) products. SDC reserves the right to make changes, corrections, modifications or improvements, to this document, and the products and services described herein at anytime, without notice. SDC does not assume any responsibility for use of any its products for any particular purpose, nor does SDC assume any liability arising out of the application or use of any its products or circuits. SDC does not convey any license under its patent rights or other rights nor the rights of others.

© 2013 Devechip Microelectronics - All rights reserved

---

Contact us:

Headquarters of Shaoxing  
Address: Tian Mu Road, No13,  
Shaoxing city, Zhejiang province, China  
Zip code: 312000  
Tel: (86) 0575-8861 6750  
Fax: (86) 0575-8862 2882

Shenzhen Branch  
Address: 22A, Shangbu building, Nan Yuan Road, No.68,  
Futian District, Shenzhen city, Guangdong province, China  
Zip code: 518031  
Tel: (86) 0755-8366 1155  
Fax: (86) 0755-8301 8528