



PRELIMINARY

SOLID STATE DEVICES, INC.

14005 Stage Road * Santa Fe Springs, Ca 90670
Phone: (562) 404-4474 * Fax: (562) 404-1773

Designer's Data Sheet

- FEATURES:**
- Hyper Fast Recovery: 35 nsec Maximum
 - High Surge Rating
 - Low Reverse Leakage Current
 - Low Junction Capacitance
 - Hermetically Sealed Package
 - Gold Eutectic Die Attach Available
 - Ultrasonic Aluminum Wire Bonds
 - TX and TXV Level Scæning Available

**SDR953/3
thru
SDR955/3**

**50 AMPS
300 - 500 V OLTS
35 nsec
HYPER FAST RECTIFIER**

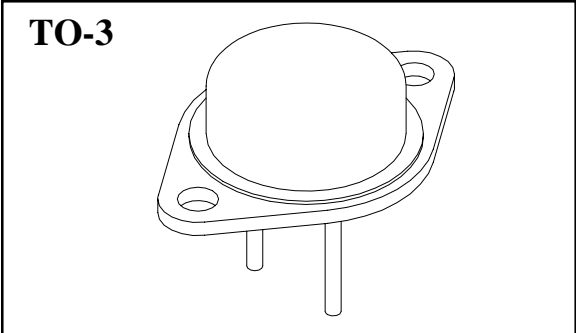

Maximum Ratings		SYMBOL	VALUE	UNITS
Peak Repetitive Reverse and DC Blocking Voltage	SDR953/3 SDR954/3 SDR955/3	V_{RRM} V_{RWM} V_R	300 400 500	Volts
Average Rectified Forward Current (Resistive load, 60Hz, Sine Wave, $T_A = 25^{\circ}C$)		I_o	50	Amps
Peak Surge Current (8.3 ms Pulse, Half Sine Wave, $T_A = 25^{\circ}C$)		I_{FSM}	800	Amps
Operating and Storage Temperature		$T_{OP} \ \& \ T_{stg}$	-65 TO +200	$^{\circ}C$
Maximum Thermal Resistance Junction to Case		$R_{\theta JC}$	1.0	$^{\circ}C/W$

NOTE: All specifications are subject to change without notification. SCD's for these devices should be reviewed by SSDI prior to release.

DATA SHEET # : RH0135B

SDR953/3 thru SDR955/3

PRELIMINARY



SOLID STATE DEVICES, INC.

14005 Stage Road * Santa Fe Springs, Ca 90670
Phone: (562) 404-4474 * Fax: (562) 404-1773

Electrical Characteristics		SYMBOL	MIN	MAX	UNITS
Instantaneous Forward Voltage Drop ($T_A = 25^\circ\text{C}$, 300 μsec Pulse)	$I_F = 25\text{A}$	V_{F1}	-	1.20	Vdc
	$I_F = 50\text{A}$	V_{F2}	-	1.45	
Instantaneous Forward Voltage Drop ($I_F = 25\text{A}$, 300 μsec Pulse)	$T_A = 100^\circ\text{C}$	V_{F3}	-	1.10	Vdc
	$T_A = -55^\circ\text{C}$	V_{F4}	-	1.30	
Reverse Leakage Current ($V_R = 80\%$ Rated, 300 μs pulse minimum)	$T_A = 25^\circ\text{C}$	I_{R1}	-	100	μA
	$T_A = 100^\circ\text{C}$	I_{R2}	-	10	mA
Breakdown Voltage ($I_R = 1\text{mA}$, $T_A = 25^\circ\text{C}$)	SDR953/3	B_{VR}	300	-	Vdc
	SDR954/3		400	-	
	SDR955/3		500	-	
Junction Capacitance ($V_R = 10\text{ Vdc}$, $T_A = 25^\circ\text{C}$, $f = 1\text{MHz}$)		C_J	-	250	pF
Reverse Recovery Time ($I_F = 500\text{mA}$, $I_R = 1.0\text{A}$, $I_{RR} = 250\text{mA}$, $T_A = 25^\circ\text{C}$)		t_{RR}	-	35	nsec

CASE OUTLINE: TO-3

CASE: CATHODE
PIN 1: ANODE
PIN 2: ANODE

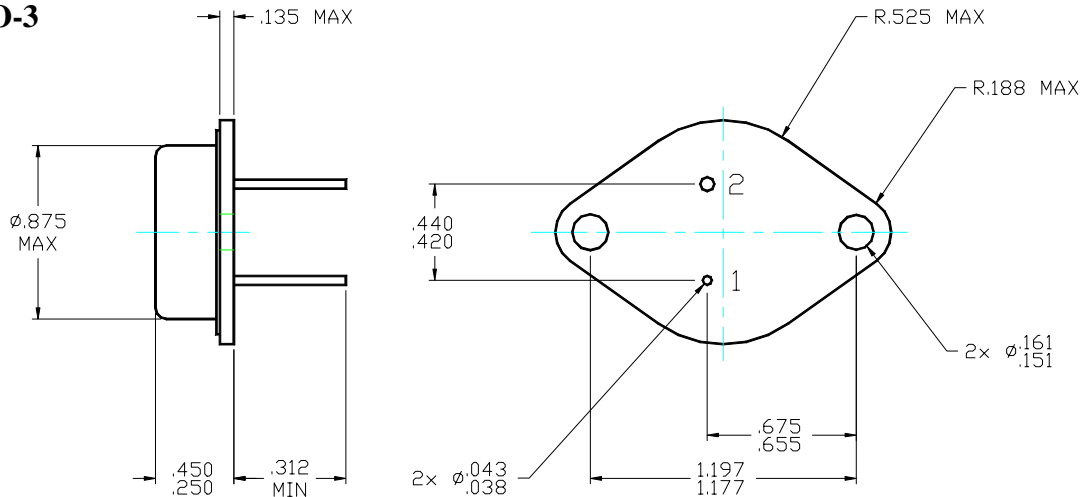

TYPICAL OPERATING CURVES

$T_A = 25^\circ\text{C}$ Unless otherwise specified

