

Electrostatic Discharged Protection Devices (ESD) Data Sheet

Description

Brightking's SDT26AXXL05 series are designed to protect sensitive electronics from damage or latch-up due to ESD and other voltage induced transient events. Each device will protect up to five lines.

They are unidirectional devices and may be used on lines where the signal polarities are above ground.

They feature large cross sectional area junctions for conducting high transient currents. They offer desirable characteristics for board level protection including fast response time, low operating and clamping voltage and no device degradation. The series may be used to meet the immunity requirements of IEC61000-4-2, level 4.



Contact : $\pm 8\text{kV}$
Air : $\pm 15\text{kV}$



Features

- IEC61000-4-2 ESD 15KV Air, 8KV contact compliance
- SOT23-6L surface mount package
- Protects five data lines
- Peak power dissipation of 350W under 8/20 μs waveform
- Working voltage: 5V, 15V and 24V
- Low leakage current
- Low clamping voltage
- Solid-state silicon avalanche technology
- Lead Free/RoHS compliant
- Solder reflow temperature: Pure Tin-Sn, 260~270 $^{\circ}\text{C}$
- Flammability rating UL 94V-0
- Meets MSL level 1, per J-STD-020

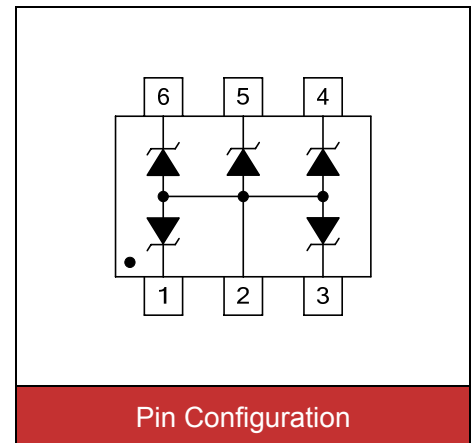

Applications

- Cell phone handsets and accessories
- Microprocessor based equipment
- Personal digital assistants (PDA's)
- Notebooks, Desktops and Servers
- Portable instrumentation
- Set Top Box
- Peripherals
- Cordless phones

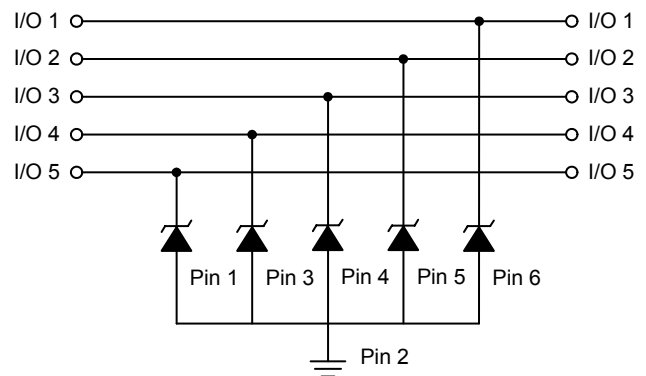

Maximum Ratings

Rating	Symbol	Value	Unit
Peak pulse power (tp=8/20μs waveform)	P _{PP}	350	W
ESD voltage (Contact discharge)	V _{ESD}	±8	kV
ESD voltage (Air discharge)		±15	
Lead soldering temperature	T _L	260	°C
Storage & operating temperature range	T _{STG} , T _J	-55~+150	°C

Electrical Characteristics (T_J=25°C)
SDT26A05L05 (Marking: TC5)

Parameter	Symbol	Condition	Min.	Typ.	Max.	Unit
Reverse stand-off voltage	V _{RWM}				5	V
Reverse breakdown voltage	V _{BR}	I _{BR} =1mA	6			V
Reverse leakage current	I _R	V _R =5V Each I/O pin			5	μA
Clamping voltage (tp=8/20μs)	V _C	I _{PP} =5A			9.5	V
Clamping voltage (tp=8/20μs)	V _C	I _{PP} =20A			18	V
Off state junction capacitance	C _J	0Vdc, f=1MHz Between I/O pins			200	pF

SDT26A15L05 (Marking: TCJ)

Parameter	Symbol	Condition	Min.	Typ.	Max.	Unit
Reverse stand-off voltage	V _{RWM}				15	V
Reverse breakdown voltage	V _{BR}	I _{BR} =1mA	16.7			V
Reverse leakage current	I _R	V _R =15V Each I/O pin			5	μA
Clamping voltage (tp=8/20μs)	V _C	I _{PP} =5A			24	V
Clamping voltage (tp=8/20μs)	V _C	I _{PP} =10A			35	V
Off state junction capacitance	C _J	0Vdc, f=1MHz Between I/O pins			70	pF

Electrical Characteristics ($T_J=25^{\circ}\text{C}$)

SDT26A24L05 (Marking: TCK)

Parameter	Symbol	Condition	Min.	Typ.	Max.	Unit
Reverse stand-off voltage	V_{RWM}				24	V
Reverse breakdown voltage	V_{BR}	$I_{BR}=1\text{mA}$	26.7			V
Reverse leakage current	I_R	$V_R=24\text{V}$ Each I/O pin			1	μA
Clamping voltage ($t_p=8/20\mu\text{s}$)	V_C	$I_{PP}=5\text{A}$			40	V
Clamping voltage ($t_p=8/20\mu\text{s}$)	V_C	$I_{PP}=7\text{A}$			50	V
Off state junction capacitance	C_J	0Vdc, $f=1\text{MHz}$ Between I/O pins			50	pF

Applications Information

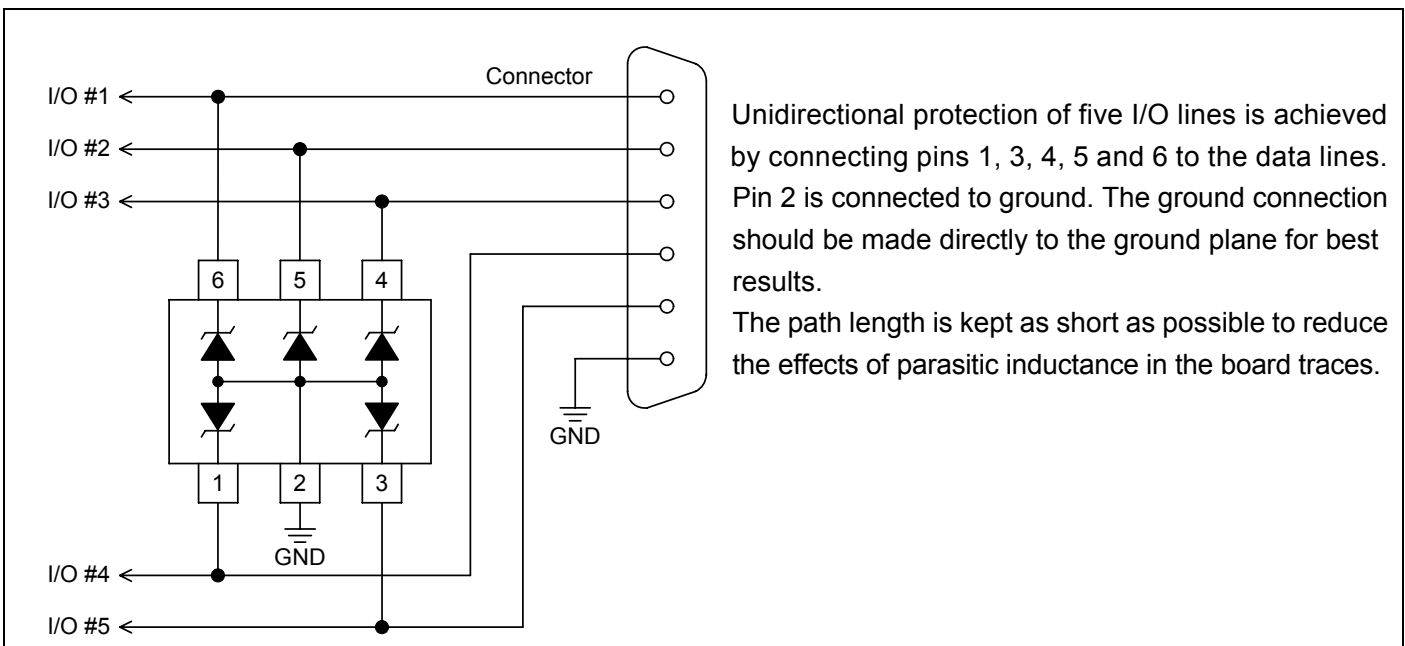

Figure 1. Keep short path length

Good circuit board layout is critical for the suppression of ESD induced transients.

The following guidelines are recommended:

- Place the SDT26AXXL05 near the input terminals or connectors to restrict transient coupling
- Minimize the path length between the SDT26AXXL05 and the protected line
- Minimize all conductive loops including power and ground loops.
- The ESD transient return path to ground should be kept as short as possible.
- Never run critical signals near board edges.
- Use ground planes whenever possible.

Typical Characteristics Curves

Figure 1. Power Derating Curve

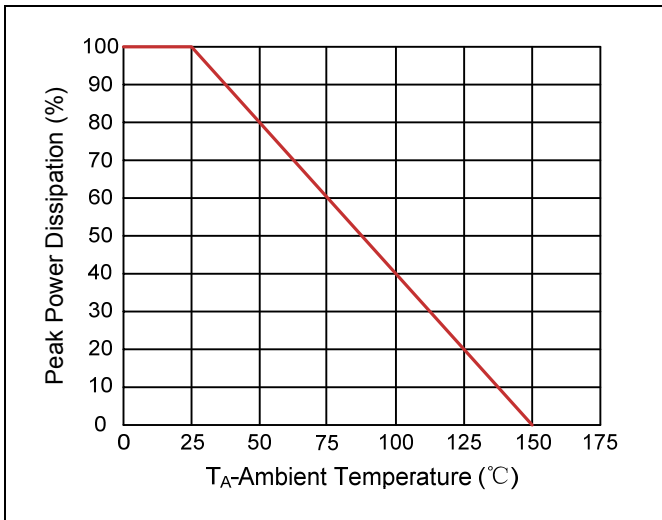

Figure 2. Pulse Waveforms

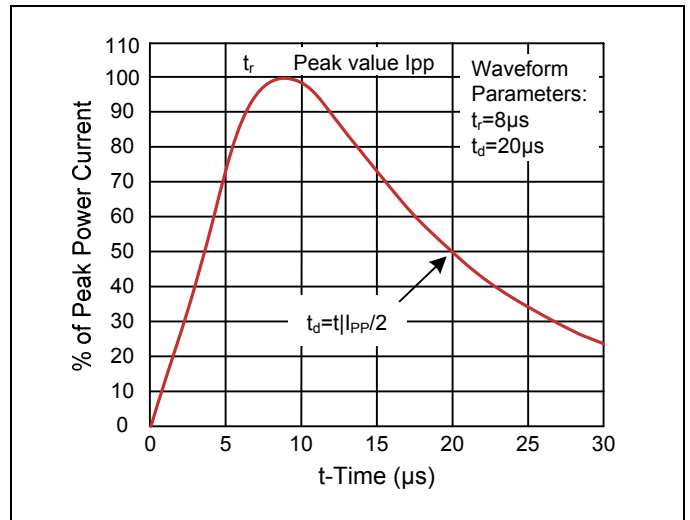

Figure 3. Non-Repetitive Peak Pulse vs. Pulse Time

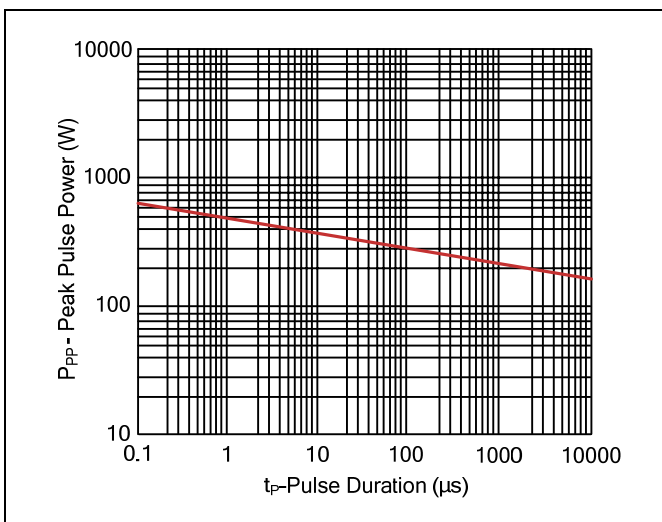
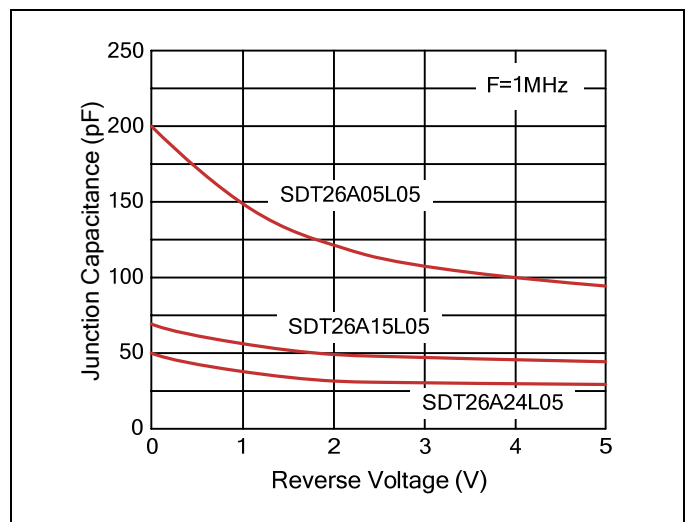
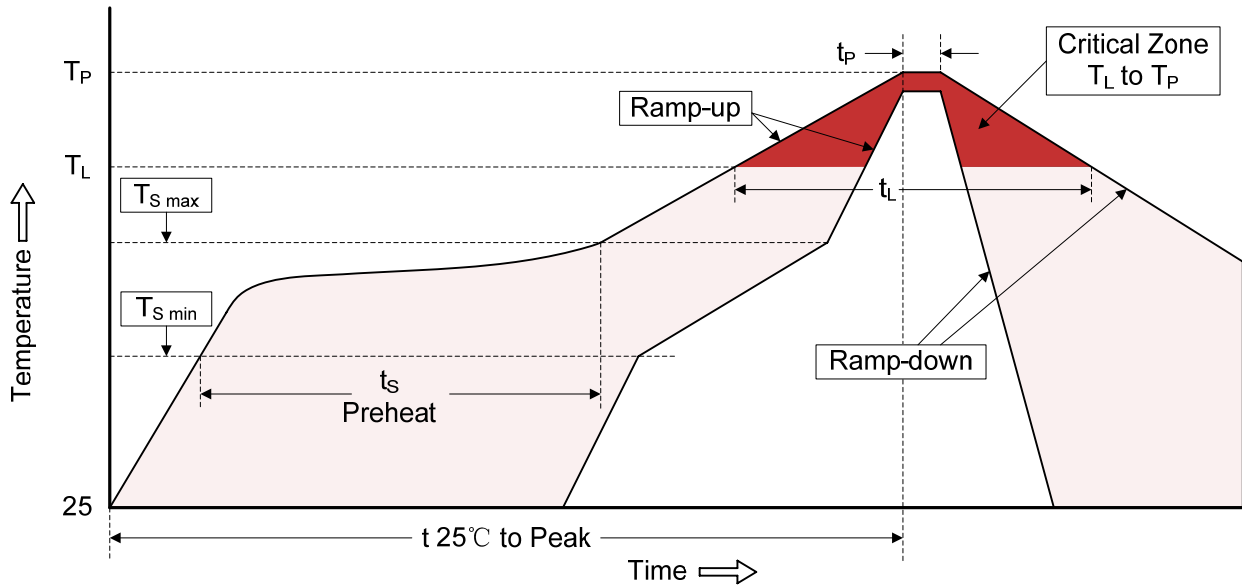

Figure 4. Capacitance vs. Reverse Voltage



Recommended Soldering Conditions

Reflow Soldering



Recommended Conditions

Profile Feature	Pb-Free Assembly
Average ramp-up rate (T_L to T_P)	3°C/second max.
Preheat -Temperature Min ($T_{S\ min}$) -Temperature Max ($T_{S\ max}$) -Time (min to max) (t_s)	150°C 200°C 60-180 seconds
$T_{S\ max}$ to T_L -Ramp-up Rate	3°C/second max.
Time maintained above: -Temperature (T_L) -Time (t_L)	217°C 60-150 seconds
Peak Temperature (T_P)	260°C
Time within 5°C of actual Peak Temperature (t_P)	20-40 seconds
Ramp-down Rate	6°C/second max.
Time 25°C to Peak Temperature	8 minutes max.

Dimensions (SOT23-6L)

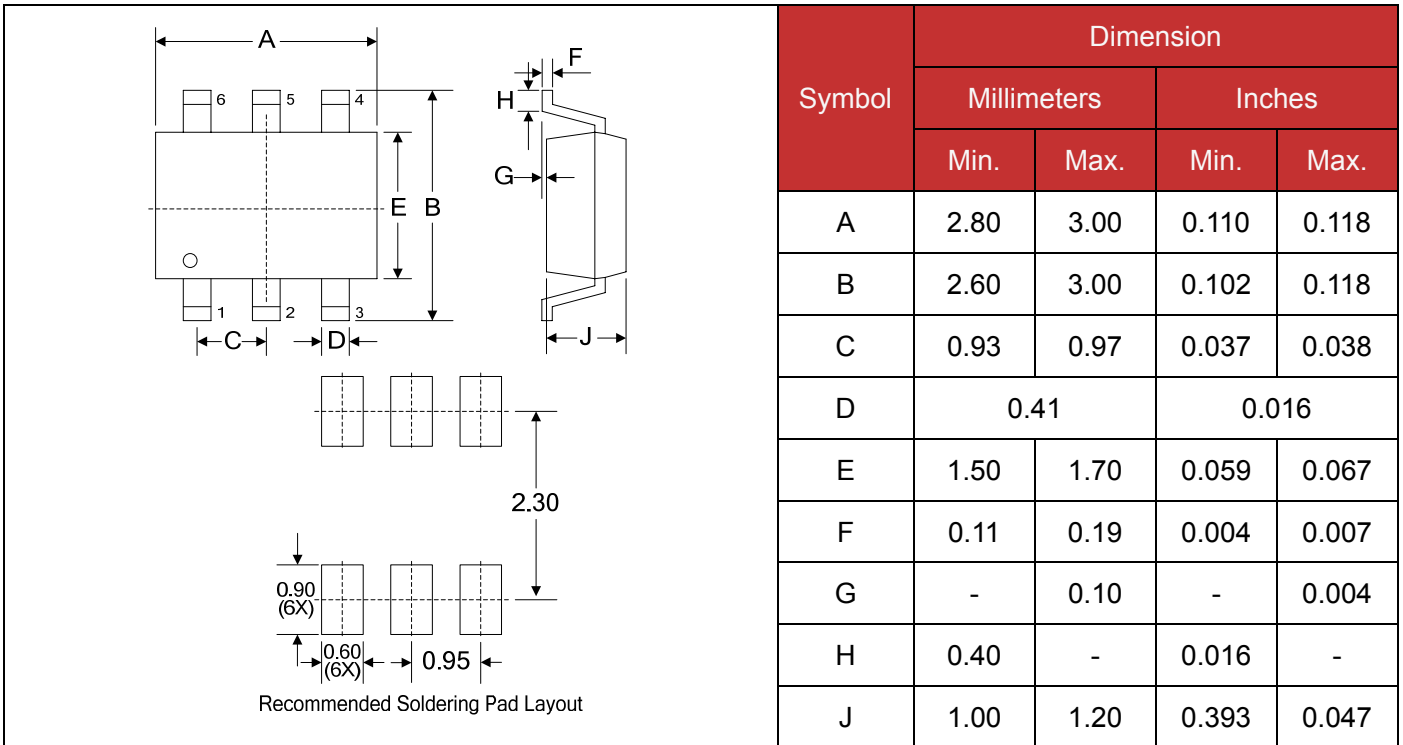

Packaging

