

Applications

- DSSS 2.4GHz WLAN (IEEE 802.11b)
- OFDM 2.4GHz WLAN (IEEE 802.11g)
- Access Points, PCMCIA, PC cards
- 2.4GHz cordless telephones

Features

- Delivers industry leading output power:
 - +19dBm, 802.11g, 54 Mbps, EVM = 2.5%
 - +23dBm, 802.11b, ACPR < -32dBc
 - +25dBm CW P_{1dB} at 3.3V
- Superior harmonic performance, No band pass filter required allowing for a lower BOM
- 31dB Gain
- Exceptional temperature stability
- Small plastic package, 12 pin QFN

Product Description

The SE2529L is a 2.4GHz, Silicon Germanium power amplifier designed for use in the 2.4GHz ISM band for wireless LAN and cordless telephone applications.

For wireless LAN applications, the device meets the system requirements of IEEE802.11g and delivers approximately +19dBm, at an EVM of 2.5%, while achieving an adjacent channel power of better than -26dBc @ 11MHz offset. The SE2529L meets this performance and output power while adhering to the FCC 15.209 restricted band requirements. For IEEE802.11b, the SE2529L delivers approximately +23dBm @ ACPR = -32dBc.

The SE2529L typically achieves harmonic performance of -65dBc with the recommended discrete integrated output match and low pass filter, thus not requiring an expensive and larger band pass filter.

Ordering Information

Type	Package	Remark
SE2529L		Samples
SE2529L-R	12 - 4x4mm QFN	Tape and Reel
SE2529L-EK1	12 - 4x4mm QFN	Evaluation Kit

Functional Block Diagram

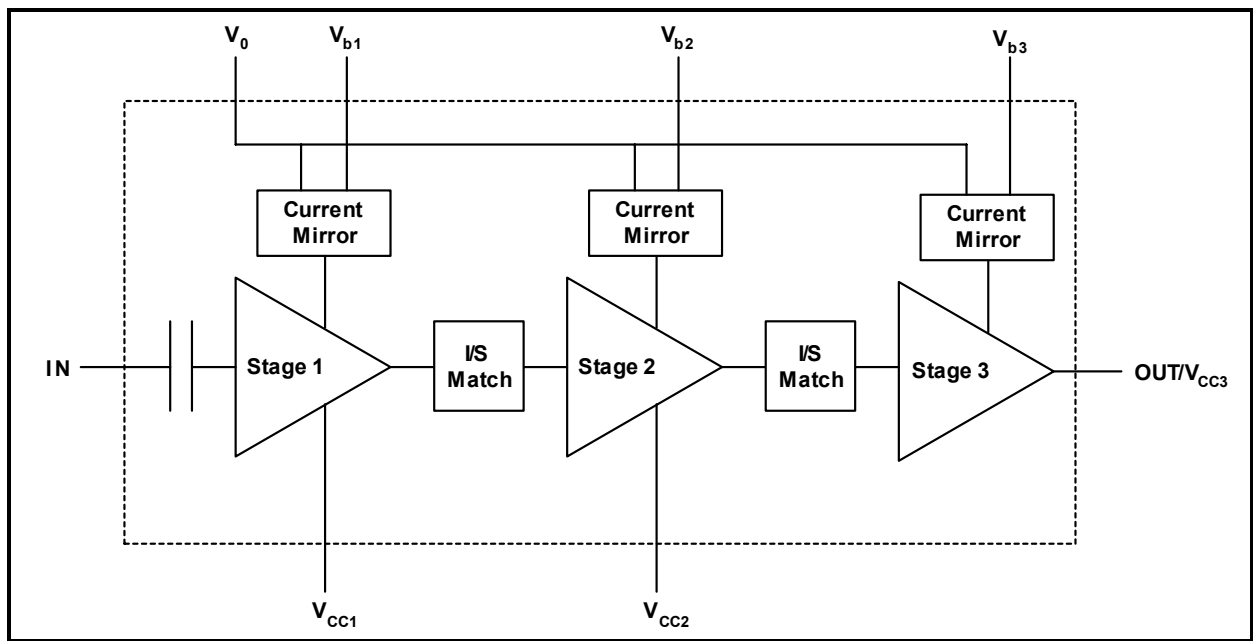

Figure 1: SE2529L Functional Block Diagram

Pin Out Diagram

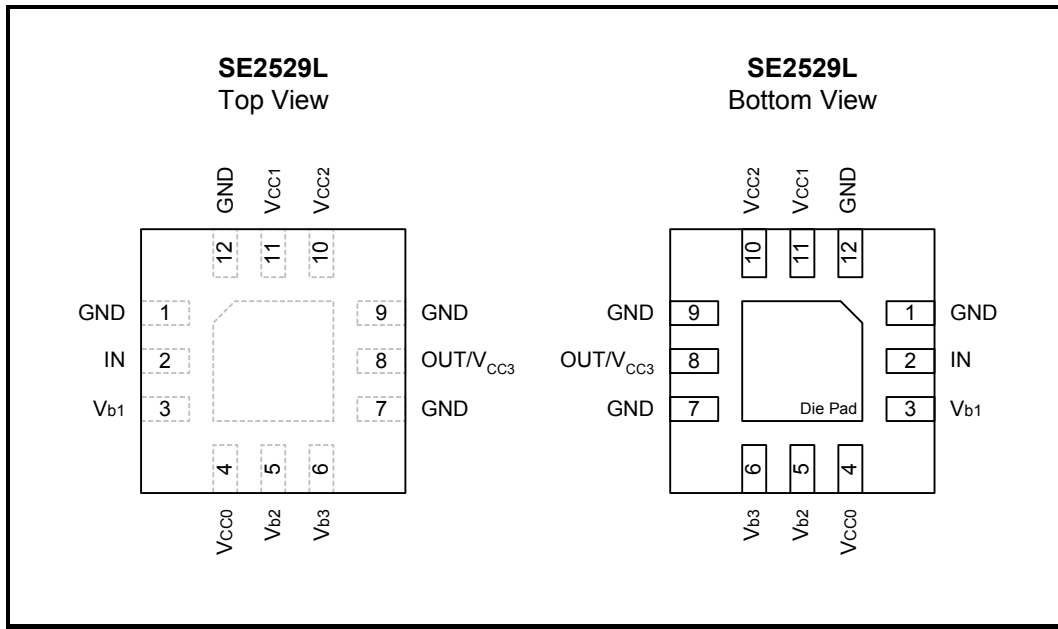

Figure 2: SE2529L Pin-Out Diagram

Pin Out Description

Pin No.	Name	Note	Description
1	GND		Ground
2	IN		Power amplifier RF input
3	V _{b1}	1	Stage 1 bias
4	V _{CC0}		Bias supply voltage
5	V _{b2}	1	Stage 2 bias
6	V _{b3}	1	Stage 3 bias
7	GND		Ground
8	OUT/ V _{CC3}		PA output and Stage 3 collector supply voltage; external output matching network with DC feed required.
9	GND		Ground
10	V _{CC2}		Stage 2 collector supply
11	V _{CC1}		Stage 1 collector supply
12	GND		Ground
Die Pad	GND		Exposed die pad; electrical and thermal ground

Notes: (1) Pin for injecting bias current – refer to SiGe Semiconductor’s applications support for optimum values for particular applications.

Equivalent Circuit Diagram

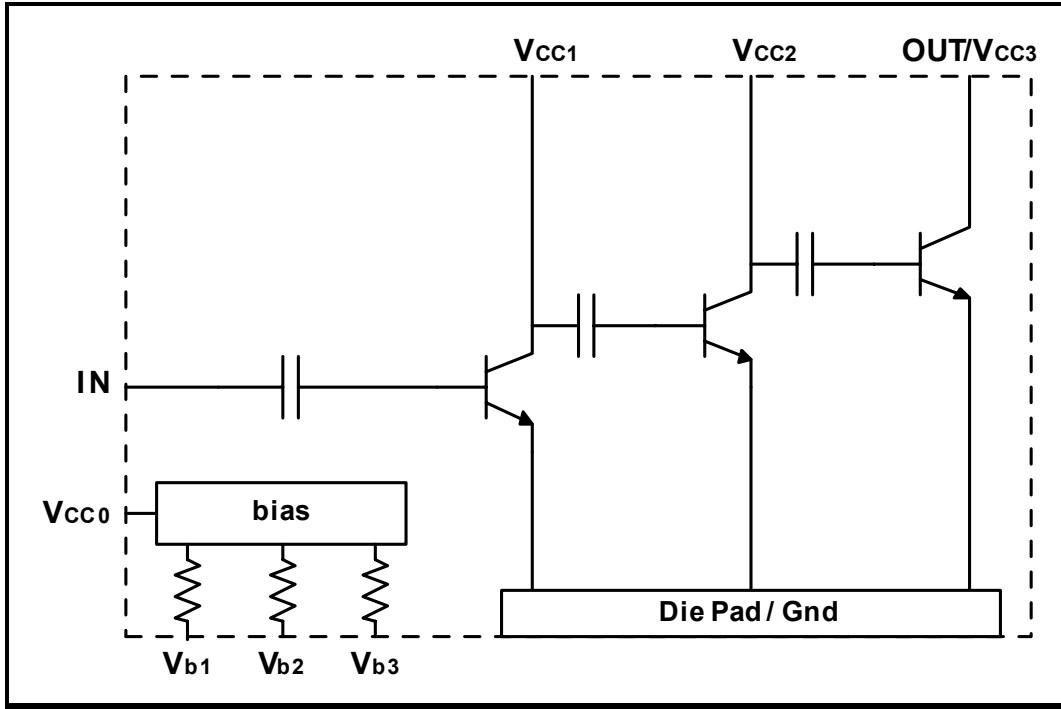

Figure 3: SE2529L Equivalent Circuit Diagram

Evaluation Board Equivalent Circuit Diagram

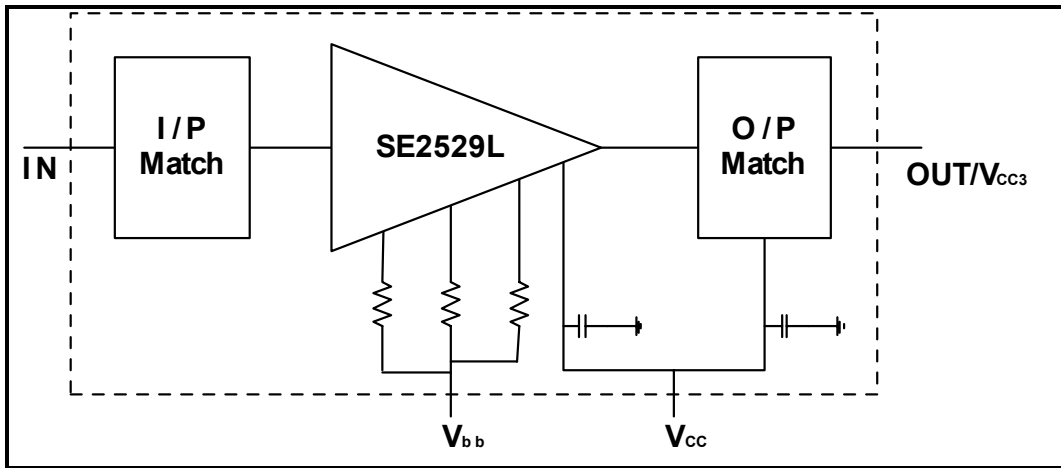

Figure 4: SE2529L Evaluation Board Block Diagram

Absolute Maximum Ratings

These are stress ratings only. Exposure to stresses beyond these maximum ratings may cause permanent damage to, or affect the reliability of the device. Avoid operating the device outside the recommended operating conditions defined below. This device is ESD sensitive. Handling and assembly of this device should be at ESD protected workstations.

Symbol	Definition	Min.	Max.	Unit
V _{CC}	Supply Voltage on V _{CC0} , V _{CC1} , V _{CC2} and OUT/V _{CC3}	-0.3	+3.6	V
V _{bb}	Bias Voltage (V _{b1} , V _{b2} , V _{b3})	-0.3	+3.6	V
IN	RF Input Power		+8	dBm
T _A	Operating Temperature Range	-40	+85	°C
T _{STG}	Storage Temperature Range	-40	+150	°C
T _j	Maximum Junction Temperature		+150	°C

Recommended Operating Conditions

Symbol	Parameter	Min.	Max.	Unit
V _{CC}	Supply Voltage (V _{CC0} , V _{CC1} , V _{CC2} , OUT/V _{CC3})	3.0	3.6	V
T _A	Ambient Temperature	-40	85	°C

DC Electrical Characteristics

802.11g DC Electrical Characteristics

Conditions: V_{CC} = 3.3V, V_{bb} = 2.9V, T_A = 25°C, as measured on SiGe Semiconductors SE2529L-EV1 evaluation board, unless otherwise noted. "802.11g" mode, circuit tuning/biasing optimized for "g" full rate signal.

Symbol	Parameter	Note	Min.	Typ.	Max.	Unit
I _{CC}	Supply Current (P _{OUT} = 19 dBm, 54 Mbps OFDM signal, 64QAM)	1	175	200	225	mA
ΔI _{CCTEMP}	Supply Current variation over temperature from T _A = 25°C (-40°C < T _A < +85°C)	1		±10		%

Notes: (1) I_{CC} refers to the total current into V_{CC0}, V_{CC1}, V_{CC2} and OUT/V_{CC3}

802.11b DC Electrical Characteristics

Conditions: V_{CC} = 3.3V, V_{bb} = 2.9V, T_A = 25°C, as measured on SiGe Semiconductors SE2529L-EV1 evaluation board, unless otherwise noted. "802.11b" mode, circuit tuning/biasing optimized for "g" full rate signal.

Symbol	Parameter	Note	Min.	Typ.	Max.	Unit
I _{CC}	Supply Current (P _{OUT} = 23dBm, 11Mbps CCK signal)	1	240	280	305	mA
ΔI _{CCTEMP}	Supply Current variation over temperature from T _A = 25°C (-40°C < T _A < +85°C)	1		±10		%

Notes: (1) I_{CC} refers to the total current into V_{CC0}, V_{CC1}, V_{CC2} and OUT/V_{CC3}

AC Electrical Characteristics

802.11G AC Electrical Characteristics

Conditions: $V_{CC} = 3.3V$, $V_{bb} = 2.9V$, $T_A = 25^\circ C$, $f = 2.45GHz$, with RF tuning optimized for 802.11g mode operation.

Symbol	Parameter	Note	Min.	Typ.	Max.	Unit
f_{L-U}	Frequency Range		2400		2500	MHz
P_{1dB}	1dB Compressed CW Output Power	1	23.5	25	28	dBm
S_{21}	Small Signal Gain (with output match and harmonic filter included)		28	31	37	dB
ΔS_{21}	Gain Variation over band (2400-2485 MHz)			1.0	2.0	dB
2f,3f,4f,5f	Harmonics	2		-65	-55	dBc
S_{21OFF}	Forward Gain when PA is off, $P_{IN} \leq 2dBm$	3		-35	-30	dB
ACPR	Adjacent Channel Power Ratio (@ 19 dBm) @ $\pm 11MHz$ offsets from carrier @ $\pm 20MHz$ offsets from carrier @ $\pm 30MHz$ offsets from carrier	4		-30 -42 -52		dBc
EVM	Error Vector Magnitude (@ 19dBm)	5		2.5		%
P/1MHz	Restricted band spectral power (@ 19dBm)	6		-43		dBm/Mhz
STAB	Stability ($P_{IN} \leq 2dBm$, Load VSWR = 6:1)		All non-harmonically related outputs less than -50 dBc/100kHz			
VSWR	Tolerance to output load mismatching		10:1 (No damage)			

- Notes:**
- (1) Matching networks optimized for 802.11g mode operation.
 - (2) With 802.11g OFDM signal at +19dBm output power.
 - (3) Device in standby mode by applying V_{b1} , V_{b2} and $V_{b3} < 1 V$.
 - (4) ACPR offsets are measured at stated offsets from center of channel. Measured with spectrum analyzer settings of 100kHz (RBW) and 30kHz (VBW).
 - (5) EVM measured on Agilent 89611A PSA/VSA analysis system.
 - (6) FCC restricted bands exist at 2310-2390 MHz and 2483.5-2500 MHz.

802.11b Electrical Characteristics

Conditions: $V_{CC} = 3.3V$, $V_{bb} = 2.9V$, $T_A = 25^\circ C$, $f = 2.45GHz$, 802.11 mode b operation, measured on SiGe Semiconductors SE2529L-EV1 evaluation board

Symbol	Parameter	Note	Min.	Typ.	Max.	Unit
f_{L-U}	Frequency Range		2400		2500	MHz
P_{1dB}	1dB Compressed CW Output Power		23.5	25	28	dBm
S_{21}	Small Signal Gain		28	31	37	dB
ΔS_{21}	Gain Variation over band (2400-2485 MHz)			1.0	2.0	dB
2f,3f,4f,5f	Harmonics	1		-65	-55	dBc
S_{21OFF}	Forward Gain when PA is off, $P_{IN} \leq 2dBm$	2		-35	-30	dB
ACPR	Adjacent Channel Power Ratio (@ 23dBm) @ $\pm 11MHz$ offsets from carrier @ $\pm 22MHz$ offsets from carrier	3		-35 -52	-30 -50	dBc
STAB	Stability ($P_{IN} \leq 2dBm$, Load VSWR = 6:1)		All non-harmonically related outputs less than -50 dBc/100kHz			
VSWR	Tolerance to output load mismatching		10:1 (No damage)			

- Notes:**
- (1) With 802.11b CCK signal at +23dBm output power.
 - (2) Device in standby mode by applying V_{b1} , V_{b2} and $V_{b3} < 1.0 V$.
 - (3) ACPR offsets are measured at $\pm 1^{st}$ side lobes and $\pm 2^{nd}$ side lobes from center carrier. Measured with spectrum analyzer settings of 100kHz (RBW) and 30kHz (VBW).

Typical Performance Characteristics

The graphs below represent the performance of the SE2529L on the SE2529L-EV1 evaluation board that is matched for optimal full-rate 54Mbps, 802.11g EVM performance. V_{bb} set point (2.9V) is also chosen for optimum 802.11g mode performance levels.

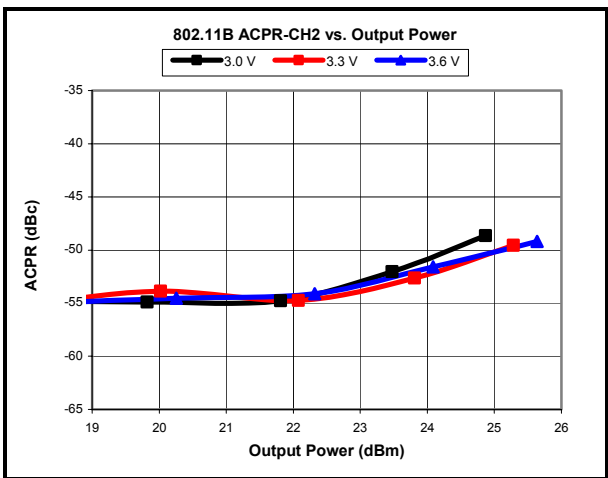
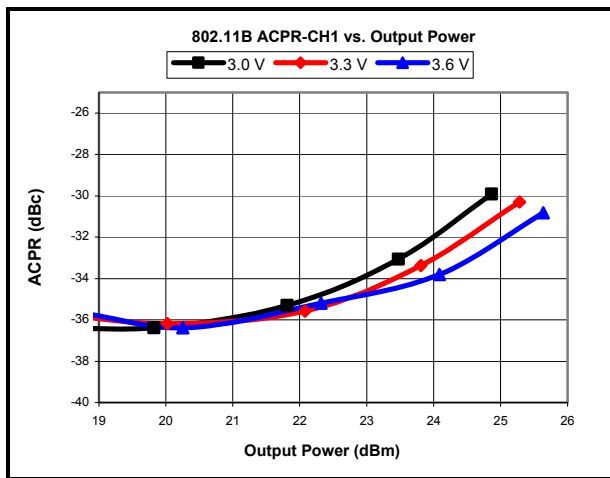
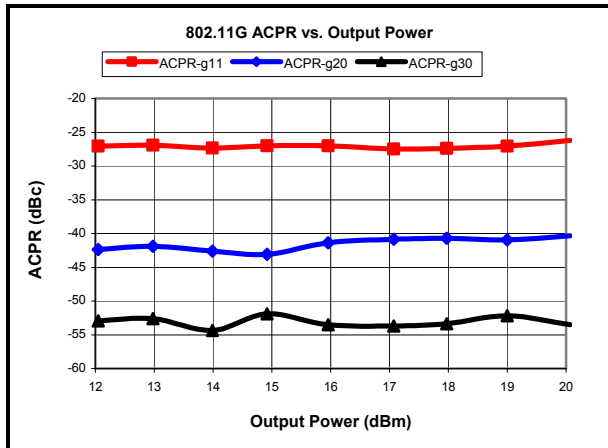
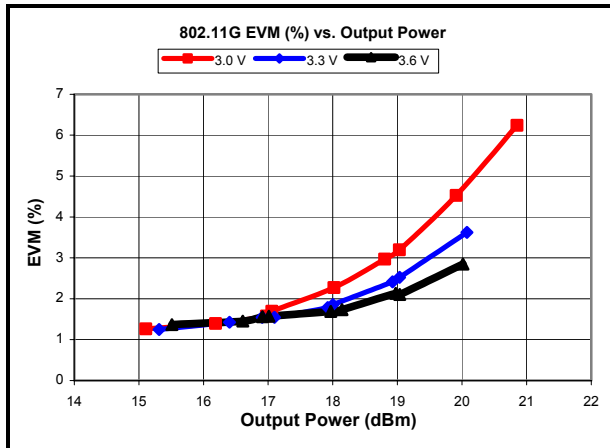
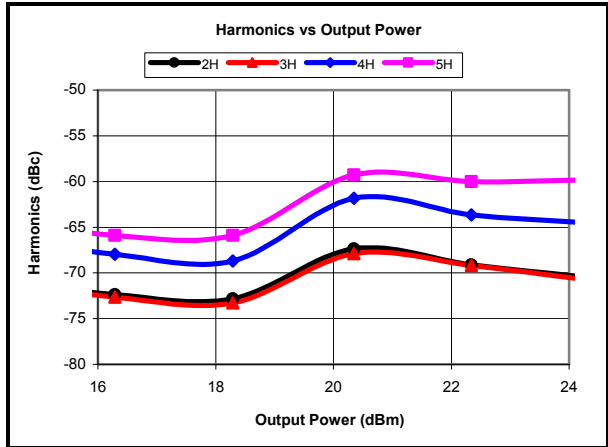
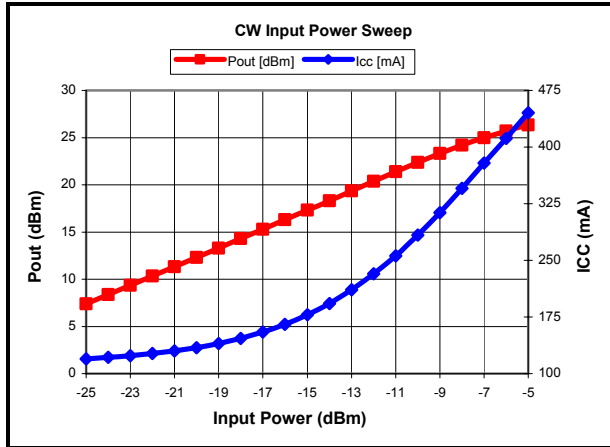

Package Information

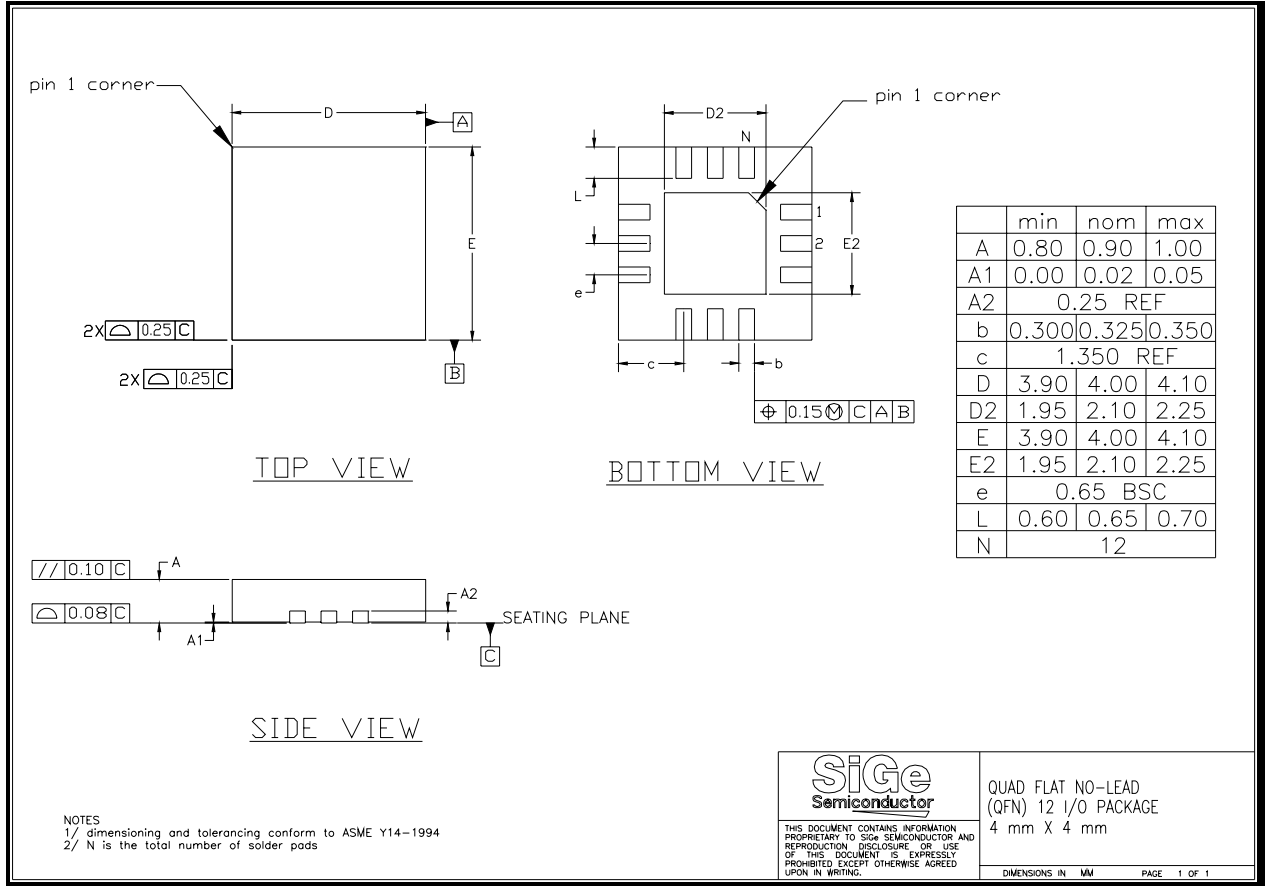

Figure 5: SE2529L Package Information

Tape and Reel Information

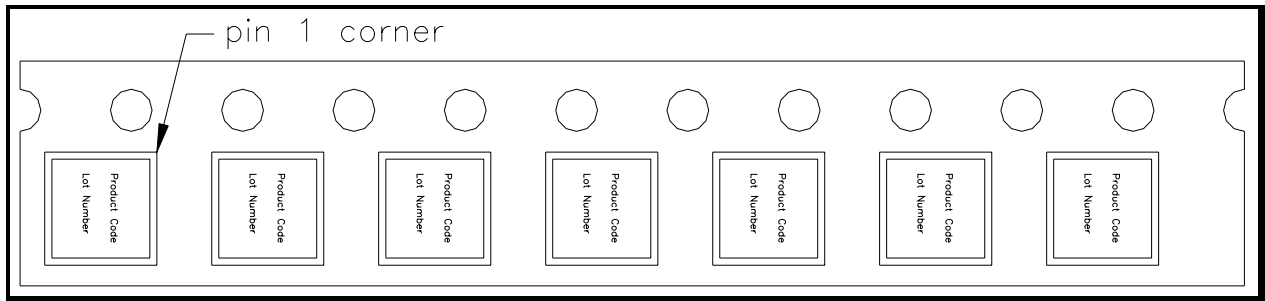

Figure 6: SE2529L Tape and Reel Information

Branding Information

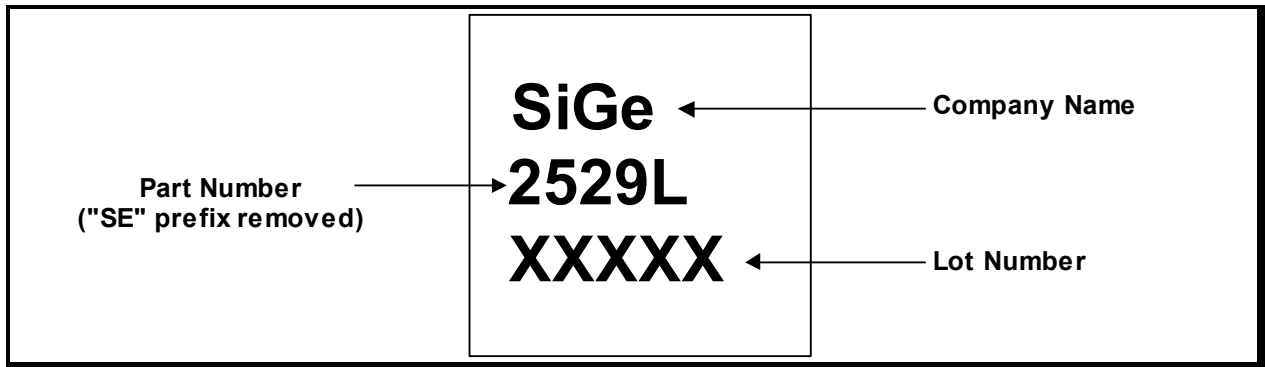

Figure 7: Branding Information

<http://www.sige.com>

Headquarters: Canada

Phone: +1 613 820 9244

Fax: +1 613 820 4933

2680 Queensview Drive

Ottawa ON K2B 8J9 Canada

sales@sige.com

San Diego

Phone: +1 858 668 3541

Fax: +1 858 668 3546

Hong Kong

Phone: +852 2491 8637

Fax: +852 2491 8937

United Kingdom

South Building, Walden Court
Parsonage Lane, Bishop's Stortford
Hertfordshire CM23 5DB

Phone: +44 1279 464 200

Fax: +44 1279 464 201

Product Preview

The datasheet contains information from the product concept specification. SiGe Semiconductor Inc. reserves the right to change information at any time without notification.

Preliminary Information

The datasheet contains information from the design target specification. SiGe Semiconductor Inc. reserves the right to change information at any time without notification.

Final

The datasheet contains information from the final product specification. SiGe Semiconductor Inc. reserves the right to change information at any time without notification. Production testing may not include testing of all parameters.

Information furnished is believed to be accurate and reliable and is provided on an "as is" basis. SiGe Semiconductor Inc. assumes no responsibility or liability for the direct or indirect consequences of use of such information nor for any infringement of patents or other rights of third parties, which may result from its use. No license or indemnity is granted by implication or otherwise under any patent or other intellectual property rights of SiGe Semiconductor Inc. or third parties. Specifications mentioned in this publication are subject to change without notice. This publication supersedes and replaces all information previously supplied. SiGe Semiconductor Inc. products are NOT authorized for use in implantation or life support applications or systems without express written approval from SiGe Semiconductor Inc.

RangeCharger™, StreamCharger™, PointCharger™, and LightCharger™ are trademarks owned by SiGe Semiconductor Inc.

Copyright 2003 SiGe Semiconductor
All Rights Reserved