



### Description

The SE432 is a low voltage three terminal adjustable shunt regulator with a guaranteed thermal stability over applicable temperature ranges. The output voltage can be set to any value between  $V_{REF}$  (approximately 1.24 V) to 12V with two external resistors. This device has a typical output impedance of  $0.25\Omega$ . Active output circuitry provides a very sharp turn on characteristic, making this device excellent replacement for Zener diodes in many applications.

The SE432 is characterized for operation from  $0^{\circ}\text{C}$  to  $105^{\circ}\text{C}$ , and four package options (SOT-23-3, SOT-23-5, TO-92 and SOP-8) allow the designer the opportunity to select the proper package for their applications.

### Features

- Low voltage operation (1.24V)
- Adjustable output voltage  $V_0 = V_{REF}$  to 12V
- Wide operating current range  $60\mu\text{A}$  to 100mA
- Low dynamic output impedance  $0.25\Omega$  (Typ.)
- Trimmed bandgap design up to  $\pm 0.5\%$ .
- ESD rating is 4KV(Per MIL-STD-883D)

### Application

- Linear Regulators
- Adjustable Supplies
- Switching Power Supplies
- Battery Operated Computers
- Instrumentation
- Computer Disk Drives

### Pin Configuration

SOT-23-3, SC59-3L (Top View)	SOT-23-5L (Top View)	SOP-8 (Top View)	TO-92 (Top View)

### Marking Information

Package	Marking	Production Year Code	Production Week Code
SOT-23-3 SC59-3L	SE432W	Starting with S, a bar on top of S is for production year 2001, and underlined S is for year 2002. The next character is marked on top for 2003, and underlined for 2004. The naming pattern continues with consecutive characters for later years.	A-Z: 1-26 a-z: 27-52
SOT-23-5L	SE432W		
SOP-8	SE432 YYWW	YY is for the year of production. 04 means the product is manufactured in year of 2004.	WW is for the week of production. 26 means the product is manufactured in the 26 <sup>th</sup> week
TO-92	SE432 YYWW		



**Absolute Maximum Rating**

Parameter	Symbol	Maximum	Units
Cathode Voltage	$V_{KA}$	12	V
Continuous Cathode Current	$I_{KA}$	150	mA
Reference Current	$I_{REF}$	3	mA
Operating Junction Temperature Range	$T_J$	150	°C
Storage Temperature Range	$T_{STG}$	-45 to 150	°C
Thermal Resistance	$\theta_{JA}$	230 (SOT-23-3)	°C/W
		230 (SOT-23-5)	
		150 (SOP-8)	
		220 (TO-92)	
Lead Temperature (Soldering) 10 seconds	$T_{LEAD}$	260	°C

**Electrical Characteristics**

Parameter	Symbol	Test Conditions & Circuit	Min	Typ	Max	Unit
Reference Voltage	$V_{REF}$	Test circuit #1 $V_{KA} = V_{REF}, I_{KA} = 10mA$	1234	1240	1246	mV
			1228	1240	1252	
			1215	1240	1265	
			1221	1240	1259	
Deviation of Reference Voltage over Full Temperature Range	$V_{I(DEV)}$	Test circuit #1 $V_{KA} = V_{REF}, I_{KA} = 10mA,$ $T_A = 0^{\circ}C - 105^{\circ}C$	--	10	25	mV
Ratio of Change in Reference Voltage to the Change in Cathode Voltage	$\Delta V_{REF}/\Delta V_{KA}$	Test circuit #2 $I_{KA} = 10mA, \Delta V_{KA} = 12V \text{ to } V_{REF}$	--	-1.0	-2.7	mV/V
Reference Current	$I_{REF}$	Test circuit #2 $I_{KA} = 10mA, R1=10k\Omega, R2 = \infty$	--	0.15	2	$\mu A$
Deviation of Reference Current over Full Temperature Range	$I_{I(DEV)}$	Test circuit #2 $I_{KA} = 10mA, R1=10k\Omega, R2 = \infty$ $T_A = 0^{\circ}C - 105^{\circ}C$	--	0.10	0.50	$\mu A$
Minimum Cathode Current for Regulation	$I_{MIN}$	Test circuit #1 $V_{KA} = V_{REF}$	--	60	100	$\mu A$
Off-state Cathode Current	$I_{OFF}$	Test circuit #3 $V_{KA} = 12V, V_{REF} = 0$	--	0.04	0.8	$\mu A$
Dynamic Impedance	$ Z_{KA} $	Test circuit #1 $I_{KA} = 100\mu A - 80mA,$ $V_{KA} = V_{REF}, f \leq 1kHz$	--	0.25	1	$\Omega$



## Typical Performance Characteristics

www.datasheet4u.com

### Cathode Current VS Cathode Voltage

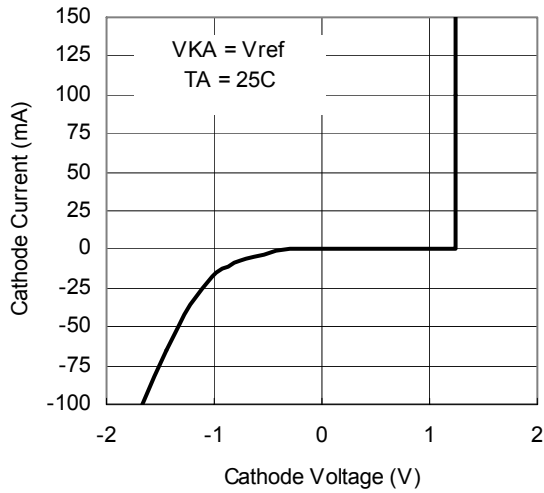

### Cathode Current VS Cathode Voltage

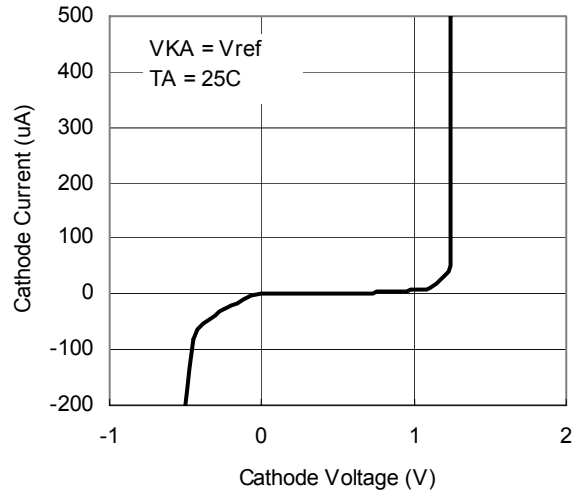

### Reference Voltage VS Junction Temperature

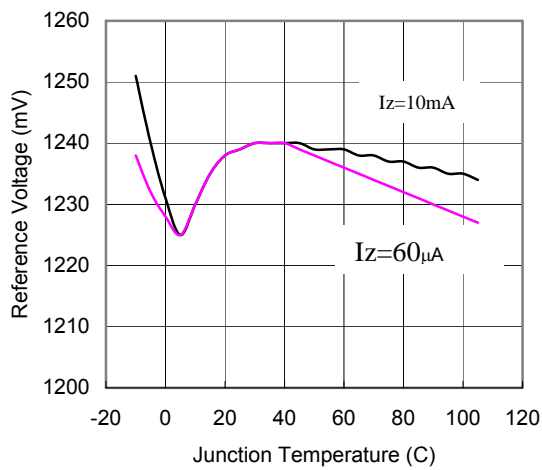

### Reference Input Current VS Junction Temperature

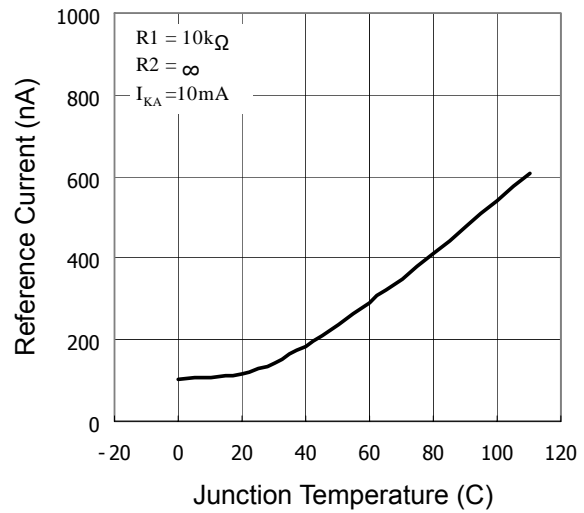



### Symbol Diagram

www.datasheet4u.com

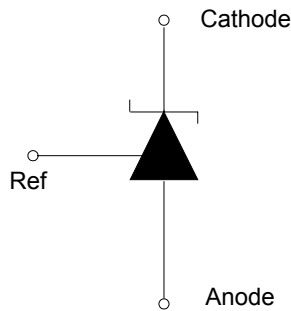

### Block Diagram

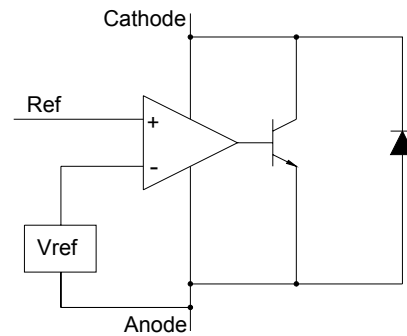

### Test Circuits

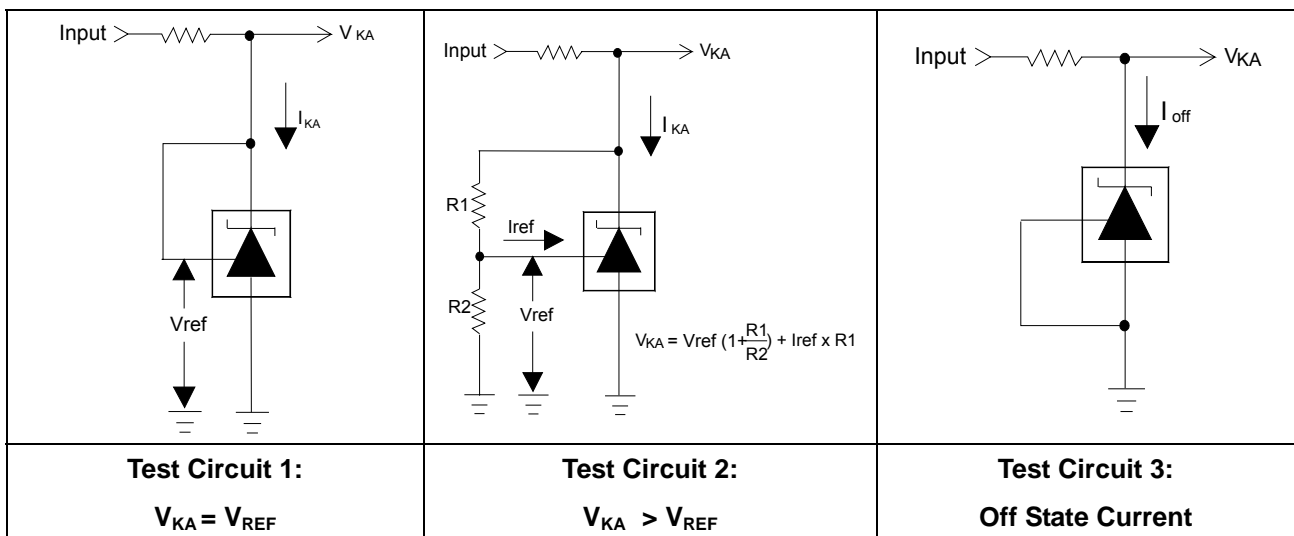

### Application Circuit

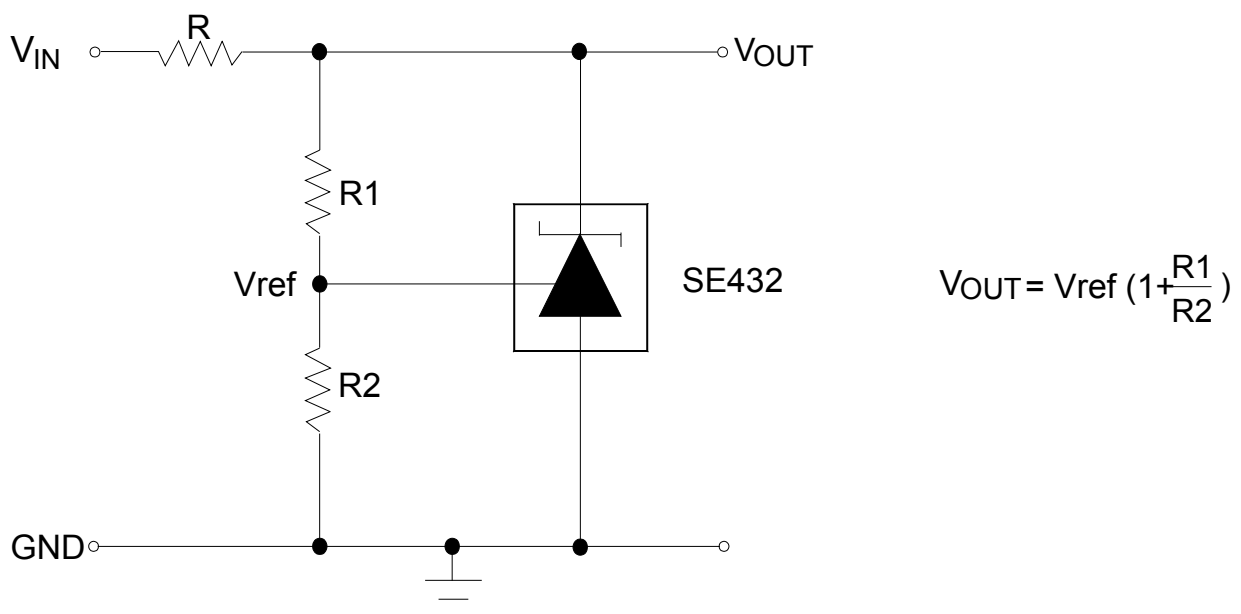



OUTLINE DRAWING SOT-23-3

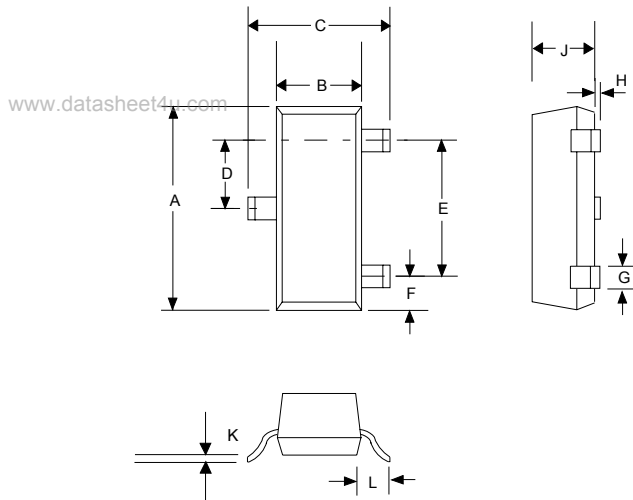

DIMENSIONS				
DIM <sup>N</sup>	INCHES		MM	
	MIN	MAX	MIN	MAX
A	0.110	0.120	2.80	3.04
B	0.047	0.055	1.20	1.40
C	0.083	0.104	2.10	2.64
D	0.035	0.040	0.89	1.03
E	0.070	0.080	1.78	2.05
F	0.018	0.024	0.45	0.60
G	0.015	0.020	0.37	0.51
H	0.0005	0.004	0.013	0.10
J	0.034	0.040	0.887	1.02
K	0.003	0.007	0.085	0.18
L	-	0.027	-	0.69

OUTLINE DRAWING SC59-3L

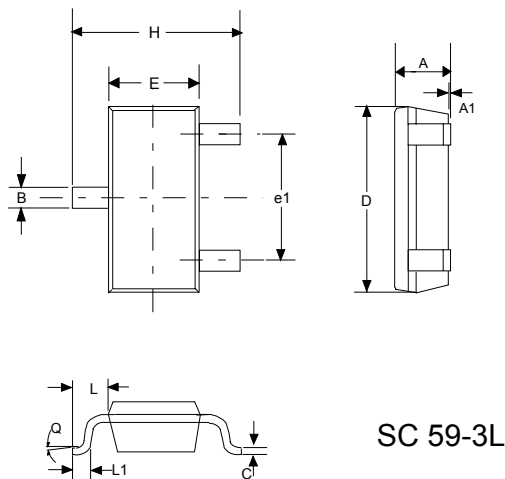

DIMENSIONS				
DIM <sup>N</sup>	INCHE		MM	
	MIN	MAX	MIN	MAX
A	0.035	0.043	0.90	1.10
A1	0.0004	0.005	0.01	0.13
B	0.012	0.020	0.30	0.50
C	0.004	0.008	0.09	0.20
D	0.110	0.122	2.80	3.10
H	0.098	0.122	2.50	3.10
E	0.059	0.067	1.50	1.70
e	0.037REF		0.95REF	
e1	0.075REF		1.90REF	
L1	0.008	0.022	0.20	0.55
L	0.014	0.031	0.35	0.80
Q	0°C	10°C	0°C	10°C

OUTLINE DRAWING SOT-23-5L

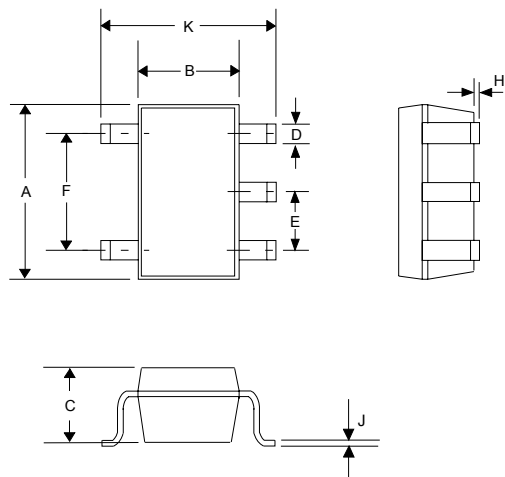

DIMENSIONS				
DIM <sup>N</sup>	INCHES		MM	
	MIN	MAX	MIN	MAX
A	0.110	0.120	2.80	3.05
B	0.059	0.070	1.50	1.75
C	0.036	0.051	0.90	1.30
D	0.014	0.020	0.35	0.50
E	-	0.037	-	0.95
F	-	0.075	-	1.90
H	-	0.006	-	0.15
J	0.0035	0.008	0.090	0.20
K	0.102	0.118	2.60	3.00



OUTLINE DRAWING SOP-8

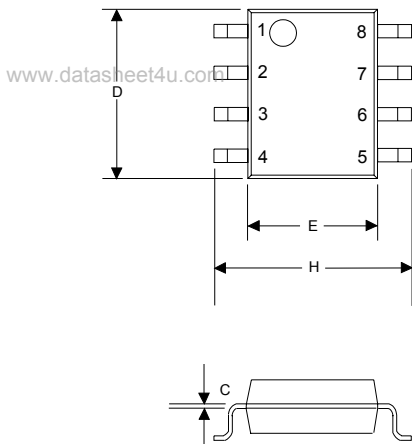

DIM <sup>N</sup>	DIMENSIONS			
	INCHES		MM	
	MIN	MAX	MIN	MAX
A	0.0532	0.0688	1.35	1.75
A1	0.0040	0.0098	0.10	0.25
B	0.0130	0.0200	0.33	0.51
B1	0.050 BSC		1.27 BSC	
C	0.0075	0.0098	0.19	0.25
D	0.1890	0.1968	4.80	5.00
H	0.2284	0.2440	5.80	6.20
E	0.1497	0.1574	3.80	4.00

OUTLINE DRAWING TO-92

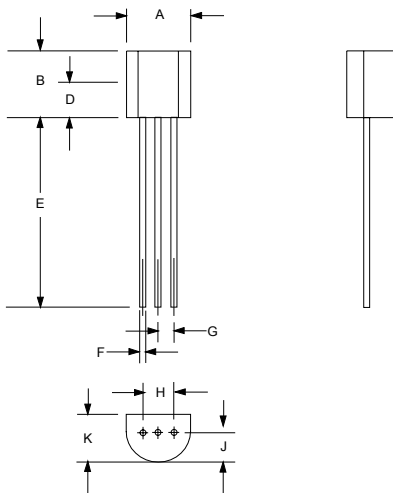

DIM <sup>N</sup>	DIMENSIONS			
	INCHES		MM	
	MIN	MAX	MIN	MAX
A	0.175	0.205	4.445	5.207
B	0.170	0.210	4.318	5.334
E	0.500	0.610	12.70	15.50
F	0.016	0.021	0.407	0.533
G	0.045	0.055	1.143	1.397
H	0.095	0.105	2.413	2.667
J	0.080	0.105	2.032	2.667
K	0.125	0.165	3.175	4.191