

LINEAR INTEGRATED CIRCUITS

DESCRIPTION

The Signetics NE501 is a direct-coupled broad-band amplifier fabricated within a monolithic silicon substrate by planar and epitaxial techniques. Typical applications include video amplifiers.

Application flexibility is provided by several external pin connections which adjust the amplifier characteristics to individual needs.

FEATURES

- ADJUSTABLE GAIN AND IMPEDANCE CHARACTERISTICS
- UNITY GAIN FREQUENCY – 150 MHz
- NOISE FIGURE – 5.0dB
- POWER DISSIPATION – 20mW

ABSOLUTE MAXIMUM RATINGS

Voltage Applied $V_{G,H,E,C}$	+8.0V
Voltage Applied V_B	±3.0V
Voltage Applied $V_{K,D}$	+4.0V
Current Rating $I_{F,J}$	±30mA
Storage Temperature	-65°C to +150°C
Operating Temperature	0°C to +70°C
NE501	-55°C to +125°C
SE501	

CIRCUIT SCHEMATIC

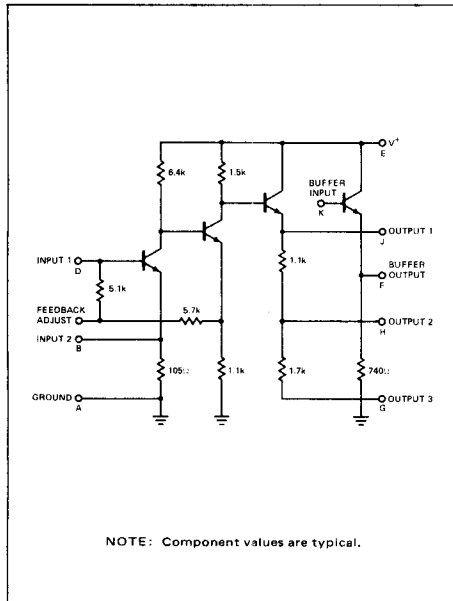

PIN CONFIGURATIONS

A PACKAGE (Top View)

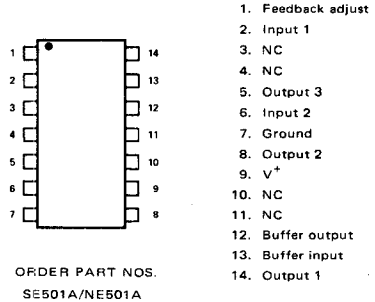

G PACKAGE

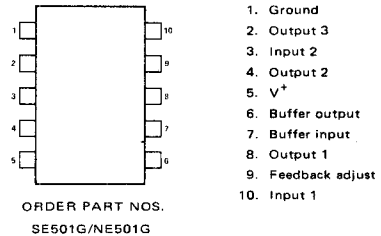

K PACKAGE

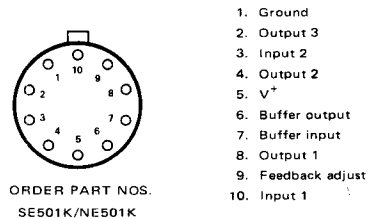

ELECTRICAL CHARACTERISTICS

PARAMETER	TEST CONDITIONS	NE501			SE501			UNITS
		MIN	TYP	MAX	MIN	TYP	MAX	
Voltage Gain	f = 50 kHz; Notes 1, 2, 6	22.5	24	26.5	23	24	26	dB
Bandwidth (-3dB)	Notes 1, 2, 6	11			14			MHz
Unity Gain Frequency	$A_{V_O} = 0$ dB; Notes 2, 6	100	150		100	150		MHz
Voltage Gain Stability	f = 50 kHz; T = 0°C; Notes 2, 6	-1.0						dB
	f = 50 kHz; T = +70°C; Notes 2, 6			+0.6				dB
	f = 50 kHz; T = -55°C; Notes 2, 6				-1.0			dB
	f = 50 kHz; T = +125°C; Notes 2, 6						+0.6	dB
Output Voltage	Notes 1, 2, 6, 9	0.71	1.0		0.71	1.0		V _{RMS}
Input Impedance	Notes 1, 8; f = 50 kHz; $V_J = V_K$	470		1200	540		1100	Ω
Output Impedance	Notes 1, 2; f = 50 kHz; $V_D = AC$ ground		12	18		12	18	Ω
Output Impedance	Notes 1, 5; f = 50 kHz; $V_D = AC$ ground		25	65		25	50	Ω
Power Dissipation				24			21	mW
Power Dissipation	$V_K = V_J$			60			53	mW
Pulse Response								
Delay Time	Notes 2, 6, 7			15			15	ns
Rise Time	Notes 2, 6, 7		12	20		12	16	ns
Noise Figure	f = 100 kHz; BW = 100 Hz; $Z_s = 500\Omega$		5.0	8.0				dB
	$f_c = 100$ kHz, BW = 100 Hz; $Z_s = 500\Omega$, $V_J = V_K$					5.0	7.0	dB

(Notes: 3, 4, 5, 8) Standard Conditions: $V_E = +6.0V$, $V_A = 0V$, $V_G = V_B$, T = +25°C (except as noted)

NOTES:

- Variations in this parameter depend on optional alternate connections as indicated in accompanying curves.
- Measured at Pin F, with Pins J and K connected.
- Pins not specifically referenced are left electrically open. All voltages are referenced to Pin A. Letter subscripts denote pins on circuit schematic.
- Positive current flow is defined as into the terminal referenced.
- Measured at Pin J.
- Load Resistance = 600 Ω , capacitively coupled.
- Delay time is defined as the time interval between the 50% points of e_D and e_P . Rise time = 20% to 80% points of e_P . Input Pulse Characteristics: Amplitude = 25mV; PW = 100ns.
- See Signetics SURE Program Bulletin No. 5001 for definition of Acceptance test Sub-Groups. Sub-Group A-7 is used for the electrical end points for Linear Products.
- Total harmonic distortion less than 5% at $e_O = 0.71 V_{RMS}$.