

PRODUCT SPECIFICATION

MODEL NO: SEL037WDHT01

< ◆ > PRELIMINARY SPECIFICATION

< ◇ > APPROVAL SPECIFICATION

CUSTOMER
APPROVED BY
DATE:

DESIGNED	CHECKED	APPROVED

Table of Contents

Table of Contents	2
Record of Revision	3
1 General Specifications	4
2 Input/Output Terminals	5
3 Absolute Maximum Ratings	6
4 Electrical Characteristics	6
5 Timing Chart	9
6 Optical Characteristics	12
7 Environmental / Reliability Test	15
8 Mechanical Drawing	16
9 Packing Drawing	17
10 Precautions for Use of LCD Modules	18

Record of Revision

Rev	Issued Date	Description	Editor
1.0	2014-11-03	Preliminary Specification Release	Songlin Feng
1.1	2015-08-03	Update optical characteristics	Songlin Feng
2.0	2015-10-13	Modify LED Current	Xunqiang Ji

1 General Specifications

Feature		Spec
Display Spec.	Size	3.7 inch
	Resolution	480(RGB) x 640
	Technology Type	a-Si
	Pixel Configuration	R.G.B. Vertical Stripe
	Pixel pitch(mm)	0.117(H)x0.117(V)
	Display Mode	Transflective
	Surface Treatment	HC
	Viewing Direction	6 o'clock
	Gray Scale Inversion Direction	12 o'clock
Mechanical Characteristics	LCM (W x H x D) (mm)	65.0 x 89.0 x 3.0
	Active Area(mm)	56.16 x 74.88
	With /Without TSP	Without TSP
	Connection Type	FPC
	LED Numbers	6 LEDs Serial
	Weight (g)	TBD
Electrical Characteristics	Interface	18 bit RGB
	Color Depth	262K
	Driver IC	HX8379-C

Note 1: Viewing direction for best image quality is different from TFT definition. There is a 180 degree shift.

Note 2: Requirements on Environmental Protection: Q/S0002

Note 3: LCM weight tolerance: $\pm 5\%$

2 Input/Output Terminals

No	Symbol	Description	Comment
1	VSS	Power Ground	
2	VSS	Power Ground	
3	VDD	Power supply input	
4	VCCIO	Logic Interface Power supply input	
5	VSS	Power Ground	
6	RESETB	System reset signal input	
7	HSYNC	Horizontal sync signal input	
8	VSYNC	Vertical sync signal input	
9	CLK	Clock input for display	
10	VSS	Power Ground	
11	D00	Display data input for (B) 00h for black display D00: LSB D05: MSB Driver IC carries out gamma conversion internally	
12	D01		
13	D02		
14	D03		
15	D04		
16	D05		
17	D10	Display data input for (G) 00h for black display D10: LSB D15: MSB Driver IC carries out gamma conversion internally	
18	D11		
19	D12		
20	D13		
21	D14		
22	D15		
23	D20	Display data input for (R) 00h for black display D20: LSB D25: MSB Driver IC carries out gamma conversion internally	
24	D21		
25	D22		
26	D23		
27	D24		
28	D25		
29	VSS	Ground	
30	DE	Input data effective signal(It is effective for the period of "H")	
31	STBYB	Standby signal (Lo: Stand by operation, Hi: Normal operation)	
32	TEST1	Connect to Ground	
33	NC	OPEN	
34	NC	OPEN	
35	NC	OPEN	
36	NC	OPEN	
37	Test2	Connect to Ground	
38	BLH	LED drive power source(Anode side)	
39	BLL	LED drive power source(Cathode side)	

Note1: I/O definition: I----Input O---Output P----Power/ Ground NC---Not Connected

3 Absolute Maximum Ratings

GND=0V, Ta=25°C

Item	Symbol	MIN	MAX	Unit	Remark
Power Supply Voltage	VDD	-0.3	3.6	V	
Logic Supply Voltage	VCCIO	-0.3	3.6	V	
Logic Input voltage	I/O PINs	-0.3	VCCIO+0.3	V	
Back Light Forward Current	I _{LED}	--	35	mA	For Each LED
Operating Temperature	T _{OPR}	-20	70	°C	
Storage Temperature	T _{STG}	-30	80	°C	

Table 3.1 Absolute maximum rating

4 Electrical Characteristics

4.1 LCD module

GND=0V, Ta=25°C

Item	Symbol	MIN	TYP	MAX	Unit	Remark
Logic Signal Input /Output Voltage	VCCIO	1.65	1.8	3.3	V	
Power Supply Voltage	VDD	2.5	3.0	3.6	V	
Input Signal Voltage	High Level	V _{IH}	0.7*IOVCC	-	IOVCC	V
	Low Level	V _{IL}	0	-	0.3*IOVCC	V
(Panel+LSI) Power Consumption	Black Mode	-	120	150	mW	
	Sleeping Mode	-	0.05	-	mW	

Table 4.1 LCD module electrical characteristics

4.2 Backlight Unit

Ta=25°C

Item	Symbol	Min	Typ	Max	Unit	Remark
Forward Current	I_F	-	20	-	mA	1 LED
Forward Voltage	V_F	-	18.6	20.4	V	BLH-BLL
Backlight Power Consumption	W_{BL}	-	372	-	mW	6 LEDs Serials
Operating Life Time	-	-	50,000	-	Hrs	For each LED

Note1: Figure below shows the connection of backlight LED.

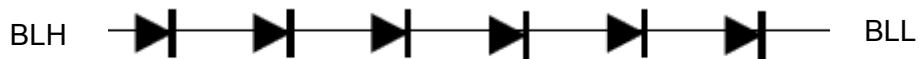

Note 2: 1LED: $V_F = 3.1V$ $I_F = 20mA$

Note 3: I_F is defined for one LED.

Optical performance should be evaluated at Ta=25°C only.

If LED is driven by high current, high ambient temperature & humidity condition. The life time of LED will be reduced. Operating life means brightness goes down to 50% initial brightness. Typical operating life time is estimated data.

4.3 Block Diagram

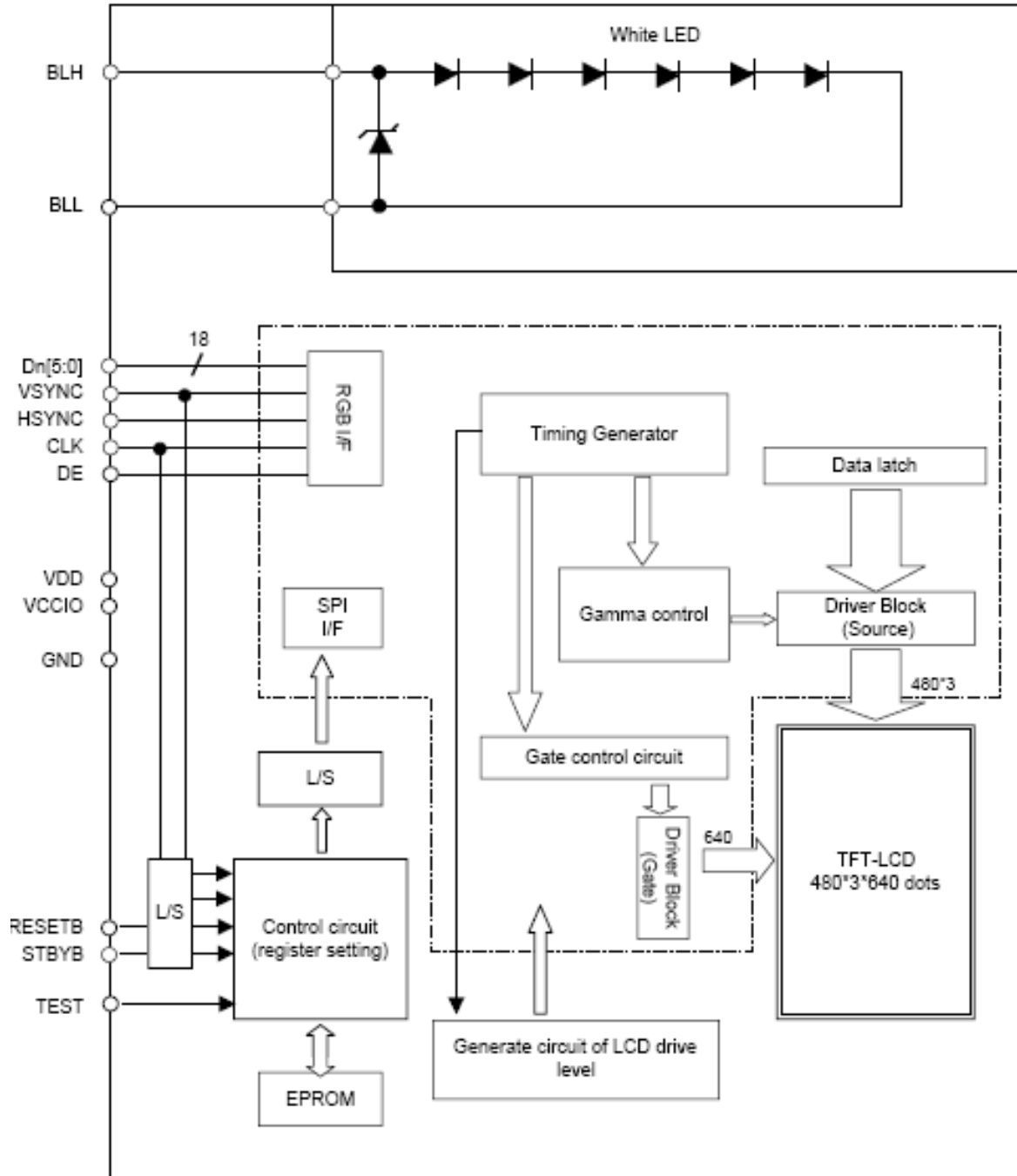

5 Timing Chart

5.1 Interface characteristics

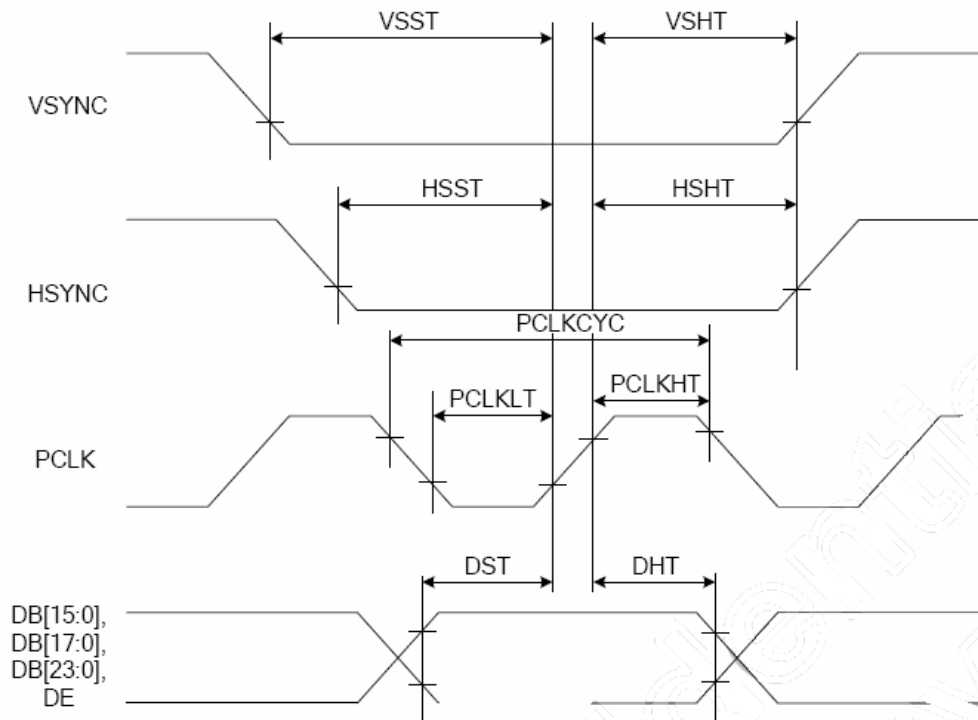

Parameter	Symbol	Condition	Min.	Typ.	Max.	Unit
Vertical sync. setup time	VSST	-	10	-	-	ns
Vertical sync. hold time	VSHT	-	10	-	-	ns
Horizontal sync. setup time	HSST	-	10	-	-	ns
Horizontal sync. hold time	HSHT	-	10	-	-	ns
Pixel clock cycle when DPI I/F is running	PCLKCYC	VRR = Min. 50 Hz Max. 70 Hz		-		ns
Pixel clock low time	PCLKLT	-	10	-	-	ns
Pixel clock high time	PCLKHT	-	10	-	-	ns
Data setup time DB[23:0]	DST	-	10	-	-	ns
Data hold time DB[23:0]	DHT	-	10	-	-	ns

5.2 Vertical timings

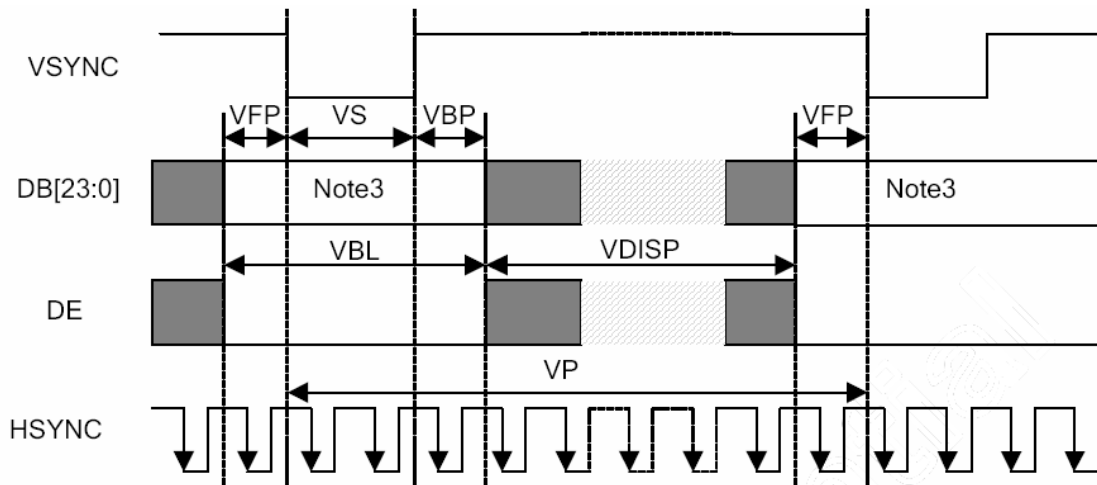

Item	Symbol	Condition	Min.	Typ.	Max.	Unit
Vertical cycle	VP	-	806	-	-	Line
Vertical low pulse width	VS	-	2	-	Note(4)	Line
Vertical front porch	VFP	-	2	-	-	Line
Vertical back porch	VBP	-	2	-	Note(4)	Line
Vertical data start point	-	VS+VBP	4	-	Note(4)	Line
Vertical blanking period	VBL	VS+VBP+VFP	6	-	-	Line
Vertical active area	-	VDISP	-	-	-	Line
Vertical Refresh rate	VRR	-	50	-	70	Hz

5.3 Horizontal Timings

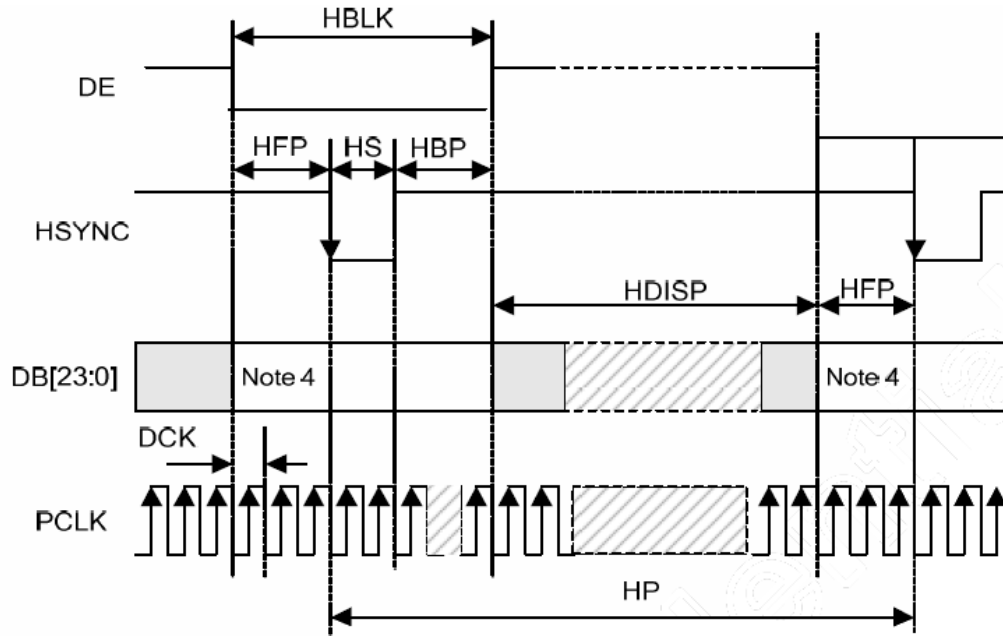

Item	Symbol	Condition	Min.	Typ.	Max.	Unit
HS cycle	HP	Note(3)	504	-	568	PCLK
HS low pulse width	HS	-	5	-	78	PCLK
Horizontal back porch	HBP	-	5	-	78	PCLK
Horizontal front porch	HFP	-	5	-	78	PCLK
Horizontal data start point	-	HS+HBP	19	-	83	PCLK
Horizontal blanking period	HBLK	HS+HBP+HFP	24	-	88	PCLK
Horizontal active area	HDISP	-	-	480	-	PCLK
Pixel clock frequency When DPI I/F is running	PCLK	VRR = Min. 50Hz Max. 70Hz		-		MHz

6 Optical Characteristics

6.1 Driving the backlight condition

Item	Symbol	Condition	Min	Typ	Max	Unit	Remark
View Angles	θ_T	$CR \geq 10$	70	80		Degree	Note2
	θ_B		30	40			
	θ_L		35	45			
	θ_R		40	50			
Contrast Ratio	CR	$\theta=0^\circ$	100	150			Note 1,3
Response Time	T_{ON}	25°C		30	40	ms	Note 1,4
	T_{OFF}						
Chromaticity	White	Backlight is on	x	(0.310)	--		Note 1,5
			y	(0.330)	--		
	Red		x	TBD	--		Note 1,5
			y	TBD	--		
	Green		x	TBD	--		Note 1,5
			y	TBD	--		
	Blue		x	TBD	--		Note 1,5
			y	TBD	--		
Uniformity	U		75	80		%	Note 6
NTSC			30	35		%	Note 5
Luminance	L		350	400		cd/m ²	Note 1,7

6.2 Not driving the backlight condition

Item	Symbol	Condition	Min	Typ	Max	Unit	Remark
View Angles	θ_T	$CR \geq 2$	45	50	--	Degree	Note 2
	θ_B		45	50	--		
	θ_L		45	50	--		
	θ_R		45	50	--		
Contrast Ratio	CR	$\theta=0^\circ$	6.0	8.0	--		Note 1,3
Chromaticity	White	Backlight is off	x	TBD	--		Note 1,5
			y	TBD	--		
Reflectance			2	4.5	--	%	Note 1,6

Test Conditions:

1. $I_F = 10$ mA(one LED), and the ambient temperature is 25°C.
2. The test systems refer to Note 1 and Note 2.

Note 1: Definition of optical measurement system.

The optical characteristics should be measured in dark room. After 5 Minutes operation, the optical properties are measured at the center point of the LCD screen. All input terminals LCD panel must be ground when measuring the center area of the panel.

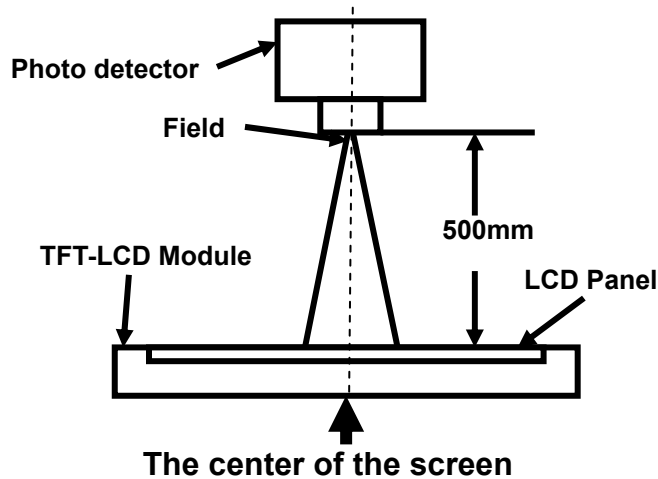

Item	Photo detector	Field
Contrast Ratio	SR-3A	1°
Luminance		
Chromaticity		
Lum Uniformity		
Response Time	BM-7A	2°

Note 2: Definition of viewing angle range and measurement system.

viewing angle is measured at the center point of the LCD by CONOSCOPE(ergo-80).

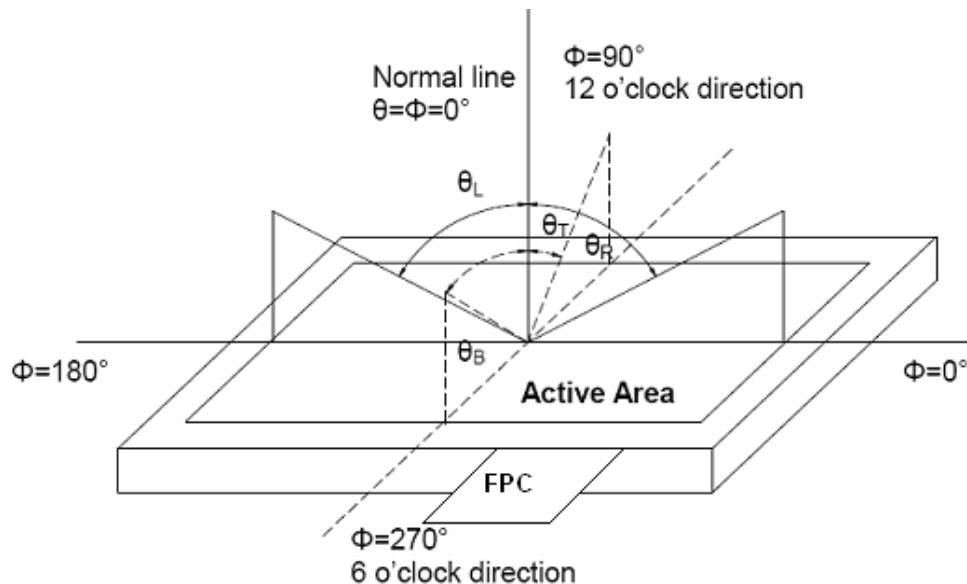

Note 3: Definition of contrast ratio

$$\text{Contrast ratio (CR)} = \frac{\text{Luminance measured when LCD is on the "White" state}}{\text{Luminance measured when LCD is on the "Black" state}}$$

“White state”: The state is that the LCD should drive by V_{white} .

“Black state”: The state is that the LCD should drive by V_{black} .

V_{white}: To be determined V_{black}: To be determined.

Note 4: Definition of Response time

The response time is defined as the LCD optical switching time interval between “White” state and “Black” state. Rise time (T_{ON}) is the time between photo detector output intensity changed from 90% to 10%. And fall time (T_{OFF}) is the time between photo detector output intensity changed from 10% to 90%.

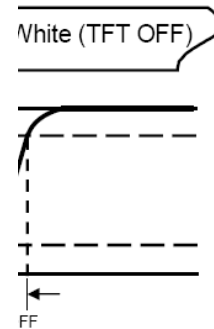

Note 5: Definition of color chromaticity (CIE1931)

Color coordinates measured at center point of LCD.

Note 6: Definition of Luminance Uniformity

Active area is divided into 9 measuring areas (Refer Fig. 2). Every measuring point is placed at the center of each measuring area.

$$\text{Luminance Uniformity (U)} = L_{\min} / L_{\max}$$

L-----Active area length W----- Active area width

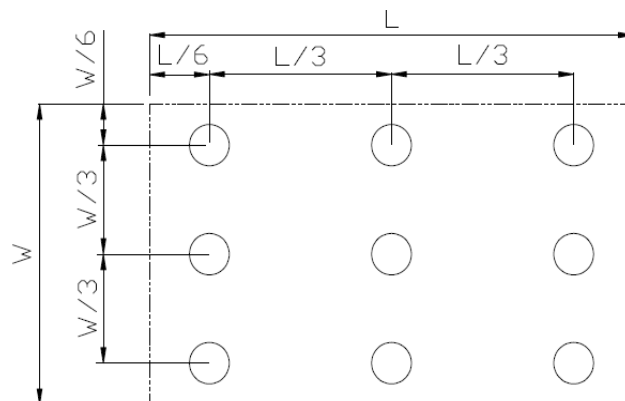

L_{max}: The measured Maximum luminance of all measurement position.

L_{min}: The measured Minimum luminance of all measurement position.

Note 7: Definition of Luminance:

Measure the luminance of white state at center point.

7 Environmental / Reliability Test

No	Test Item	Condition	Remarks
1	High Temperature Operation	Ts=+70°C, 240hrs	IEC60068-2-1:2007 GB2423.2-2008
2	Low Temperature Operation	Ta=-20°C, 240hrs	IEC60068-2-1:2007 GB2423.1-2008
3	High Temperature Storage	Ta=+80°C, 240hrs	IEC60068-2-1:2007 GB2423.2-2008
4	Low Temperature Storage	Ta=-30°C, 240hrs	IEC60068-2-1:2007 GB2423.1-2008
5	High Temperature and Humidity Operation	Ta=+60°C, 90% RH, 240 hours	IEC60068-2-78 :2001 GB/T2423.3—2006
6	Thermal Shock (non-operation)	-30°C 30 min~+80°C 30 min, Change time:5min, 100 Cycles	Start with cold temperature, End with high temperature, IEC60068-2-14:1984,G B2423.22-2002
7	Electro Static Discharge (Non operation)	C=200pF, R=0Ω, V=±200V Each 3 times of discharge on and power supply and other terminals	
7	Electro Static Discharge (operation)	C=150pF, R=330Ω,5points/panel Air:± 16KV, 5times, Contact:± 8KV, 5 times, (Environment: 15°C ~35°C, 30%~60%, 86Kpa~106Kpa)	IEC61000-4-2:2001 GB/T17626.2-2006
8	Vibration Test	Frequency range:10~55Hz, Stroke:1.5mm, Sweep:10Hz~55Hz~10Hz, 2h for x,y,z (total 6h)	IEC60068-2-6:1982 GB/T2423.10—1995
9	Mechanical Shock (non-operation)	Half-sine 1000m/s ² , 6ms, ± X,± Y,± Z 3times, for each direction	IEC60068-2-27:1987 GB/T2423.5—1995
10	Package Drop Test	Height:80 cm,1 corner, 3 edges, 6 surfaces	IEC60068-2-32:1990 GB/T2423.8—1995

Note1: Ts is the temperature of panel's surface.

Note2: Ta is the ambient temperature of sample.

Note3: Before cosmetic and function test, the product must have enough recovery time, at least 2 hours at room temperature.

Note 4: In the standard condition, there shall be no practical problem that may affect the display function. After the reliability test, the product only guarantees operation, but don't guarantee all of the cosmetic specification.

8 Mechanical Drawing

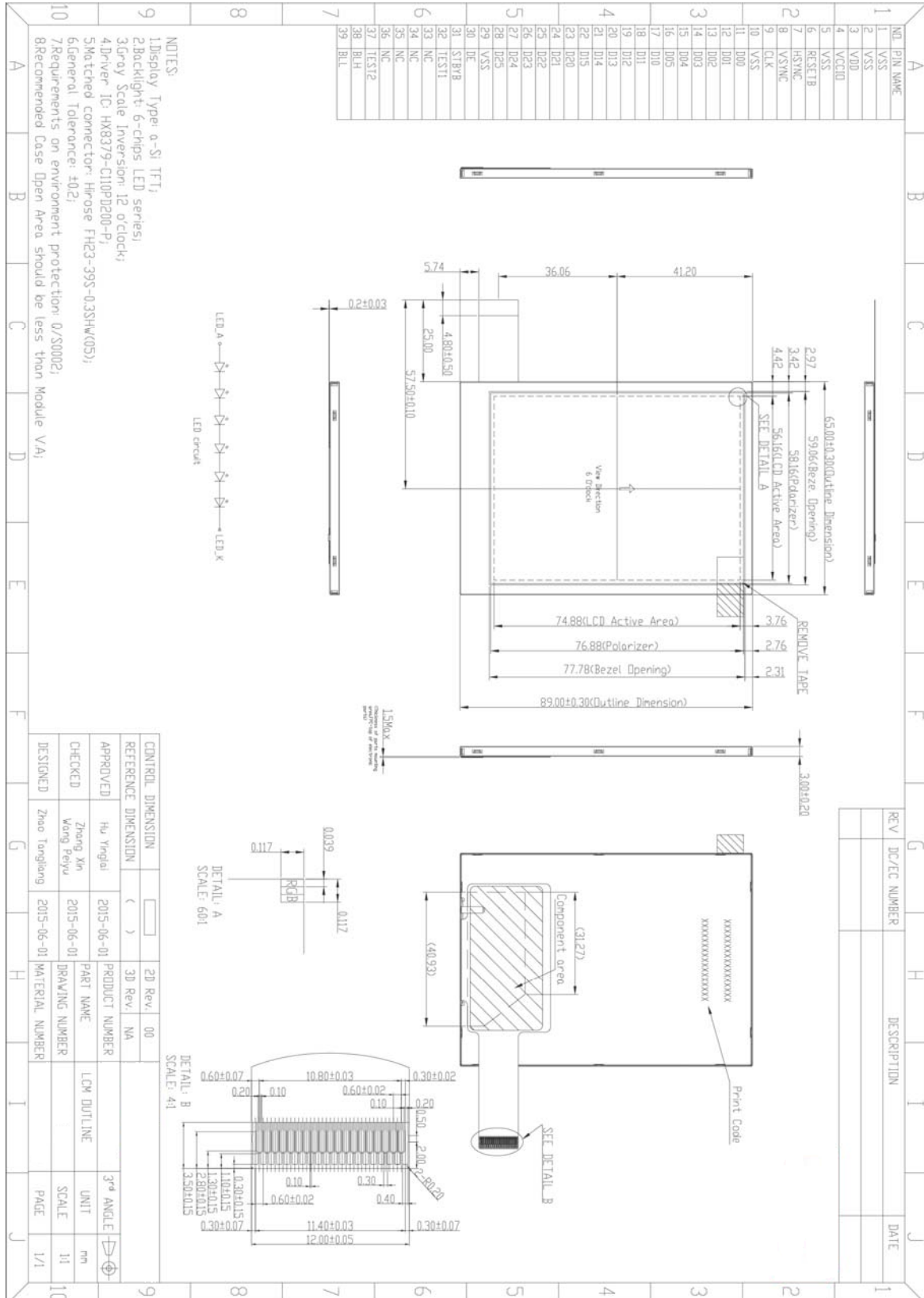

9 Packing Drawing

No.	Item	Model (Material)	Dimensions(mm)	Unit Weight(Kg)	Quantity	Remark
1	LCM module	SEL037WDH01-00	65×89×3	TBD	216	
2	Carton	Corrugated paper	544×365×250	0.76	1	
3	Dust-Proof Bag	PE	700×545×0.05	0.06	1	
4	Desiccant	DESICCANT	45×35	0.002	6	
5	Tray	PET(Transmit)	485×330×14.8	0.17	21	
6	BOX	Corrugated paper	520×345×74	0.40	3	
7	EPE	EPE	420×289.6×1	TBD	18	
8	Total weight	TBD				

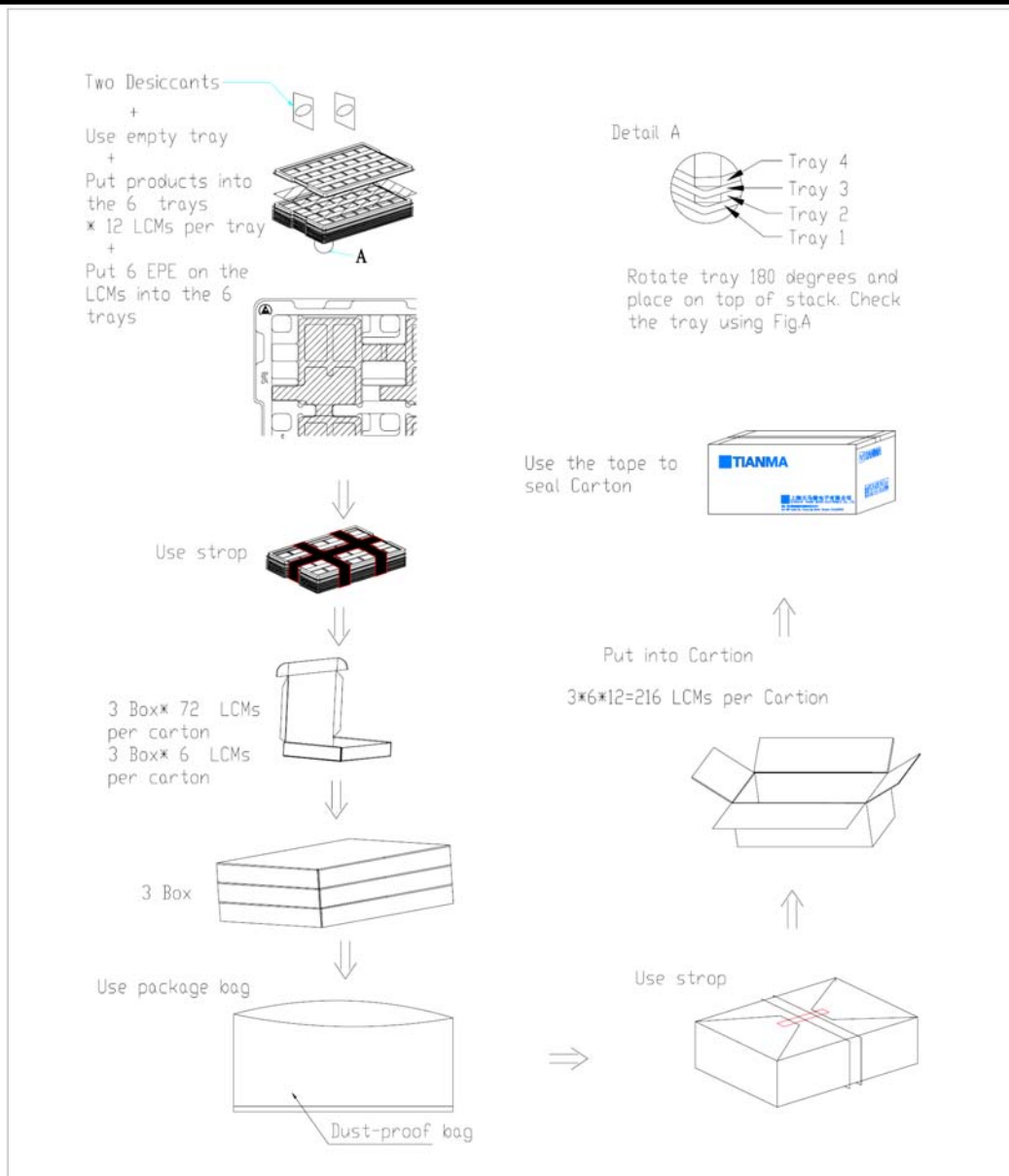

10 Precautions for Use of LCD Modules

10.1 Handling Precautions

10.1.1 The display panel is made of glass. Do not subject it to a mechanical shock by dropping it from a high place, etc.

10.1.2 If the display panel is damaged and the liquid crystal substance inside it leaks out, be sure not to get any in your mouth, if the substance comes into contact with your skin or clothes, promptly wash it off using soap and water.

10.1.3 Do not apply excessive force to the display surface or the adjoining areas since this may cause the color tone to vary.

10.1.4 The polarizer covering the display surface of the LCD module is soft and easily scratched. Handle this polarizer carefully.

10.1.5 If the display surface is contaminated, breathe on the surface and gently wipe it with a soft dry cloth. If still not completely clear, moisten cloth with one of the following solvents:

- Isopropyl alcohol
- Ethyl alcohol

Solvents other than those mentioned above may damage the polarizer. Especially, do not use the following:

- Water
- Ketone
- Aromatic solvents

10.1.6 Do not attempt to disassemble the LCD Module.

10.1.7 If the logic circuit power is off, do not apply the input signals.

10.1.8 To prevent destruction of the elements by static electricity, be careful to maintain an optimum work environment.

10.1.8.1 Be sure to ground the body when handling the LCD Modules.

10.1.8.2 Tools required for assembly, such as soldering irons, must be properly ground.

10.1.8.3 To reduce the amount of static electricity generated, do not conduct assembly and other work under dry conditions.

10.1.8.4 The LCD Module is coated with a film to protect the display surface. Be care when peeling off this protective film since static electricity may be generated.

10.2 Storage precautions

10.2.1 When storing the LCD modules, avoid exposure to direct sunlight or to the light of fluorescent lamps.

10.2.2 The LCD modules should be stored under the storage temperature range. If the LCD modules will be stored for a long time, the recommend condition is:

Temperature : 0°C ~ 40°C Relatively humidity: ≤80%

10.2.3 The LCD modules should be stored in the room without acid, alkali and harmful gas.

10.3 Transportation Precautions

10.3.1 The LCD modules should be no falling and violent shocking during transportation, and also should avoid excessive press, water, damp and sunshine.