

SELU2410C–TG



- External Shape Type: $\phi 3$ Round shape type LED
- Color : Green
- Lens color : Clear
- Material of a chip : AlGaInP
- Application : Home Appliance, Office Appliance(Factory Automation),General display.
- Feature : High Intensity Type,RoHS compliant, Compatible with heat–resistance of lead–free solder.

● Absolute Maximum Ratings (Ta=25°C)

Parameter	Symbol	Ratings	Unit	Remarks
Forward current	IF	30	mA	
Forward current derating	Δ IF	-0.45	mA/°C	25°C or more
Pulse forward current	IFP	100	mA	f=1kHz , tw \leq 100 μ s
Reverse voltage	VR	3	V	
Operating temperature	Topr	-30~85	°C	
Storage temperature	Tstg	-30~100	°C	

● Electro – optical characteristics (Ta=25°C)

Parameter	Symbol	Condition	MIN	TYP	MAX	Unit
Forward voltage	VF	IF = 20mA		2.1	2.5	V
Reverse current	IR	VR=3V			10	μ A
Luminous intensity	IV	IF = 20mA	128	300		mcd
Peak wavelength	λ_p	IF = 20mA		564		nm
Dominant wavelength	λ_d	IF = 20mA		563.5		nm
Spectral bandwidth	$\Delta\lambda$	IF = 20mA		15		nm
Directional angle	$2\theta_{1/2}$	IF = 20mA		40		deg.

● Luminous intensity rank (Ta=25°C)

Rank	Luminous intensity range(mcd)	
C	128	~ 256
D	171	~ 341
E	228	~ 455
F	304	~

● Dominant wavelength rank(Ta=25°C)

Rank	Dominant wavelength range	
G	561.0	~ 563.5
Y	563.5	~ 566.0

(Tolerance: ± 2 nm)

● Characteristic data

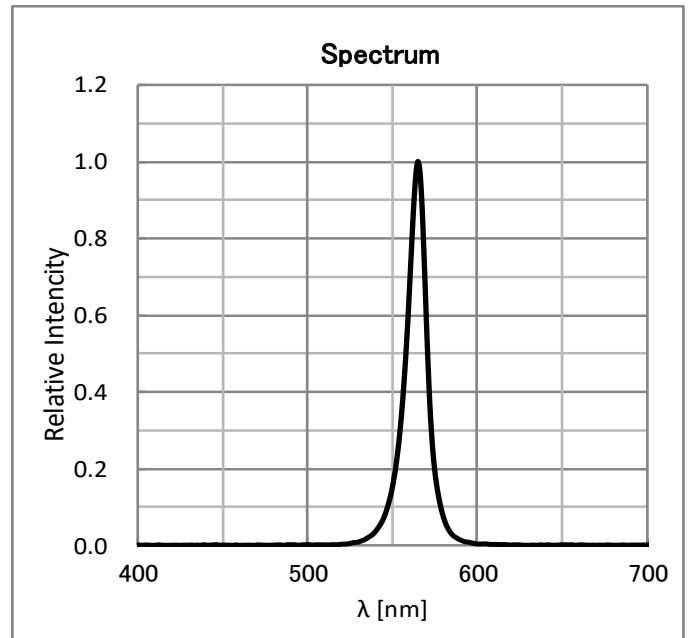
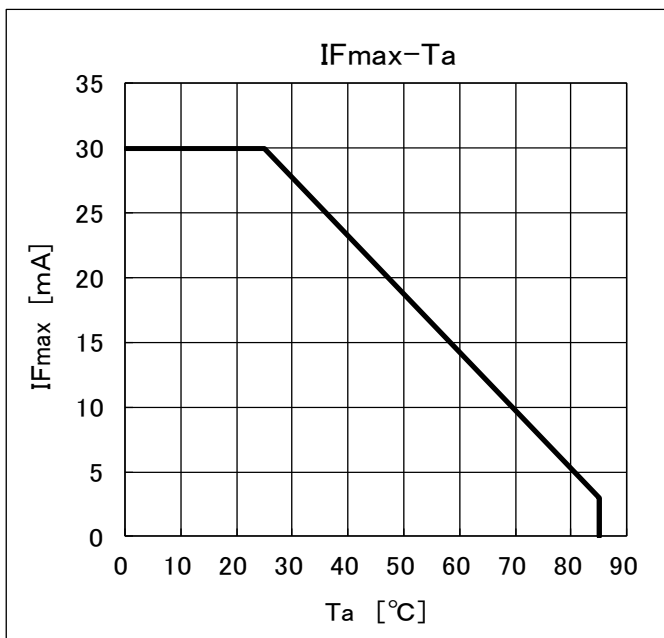
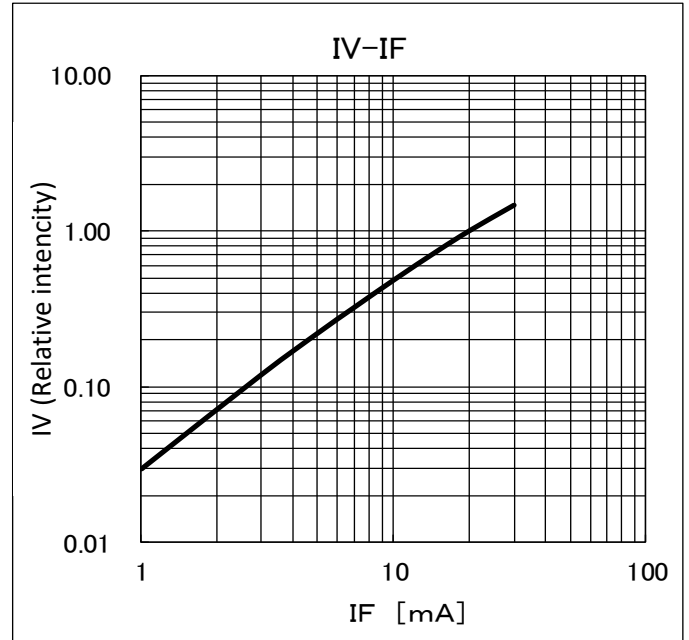
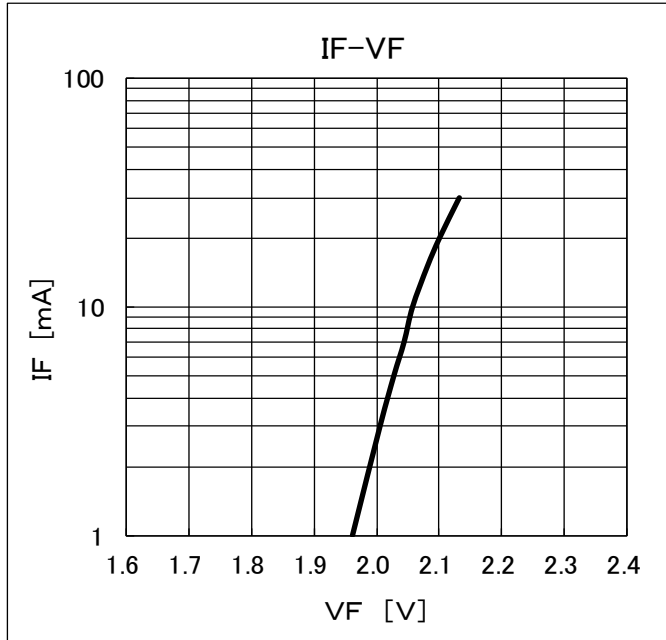

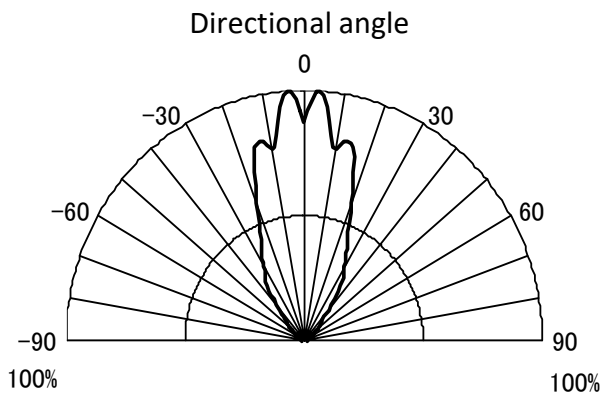
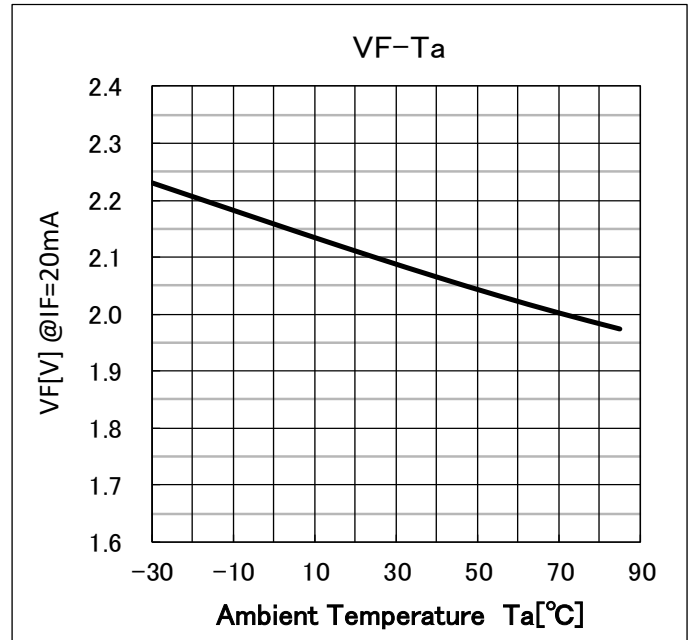
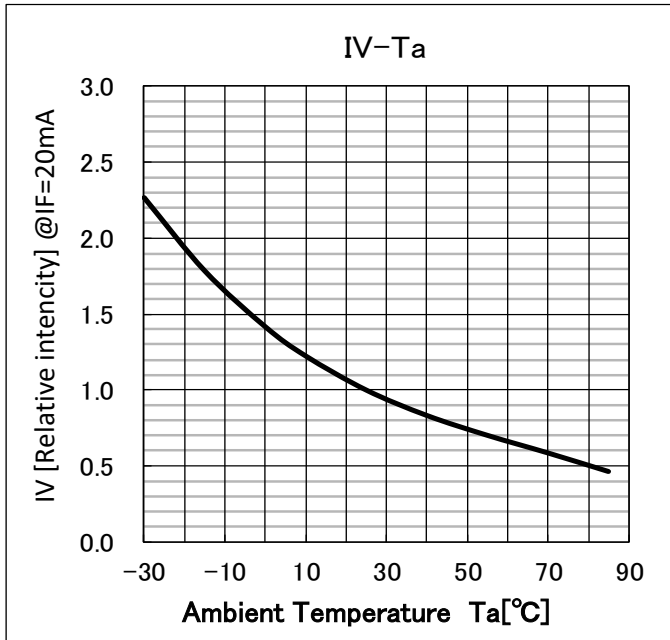

- SEL2010 Series
- Outline dimensions

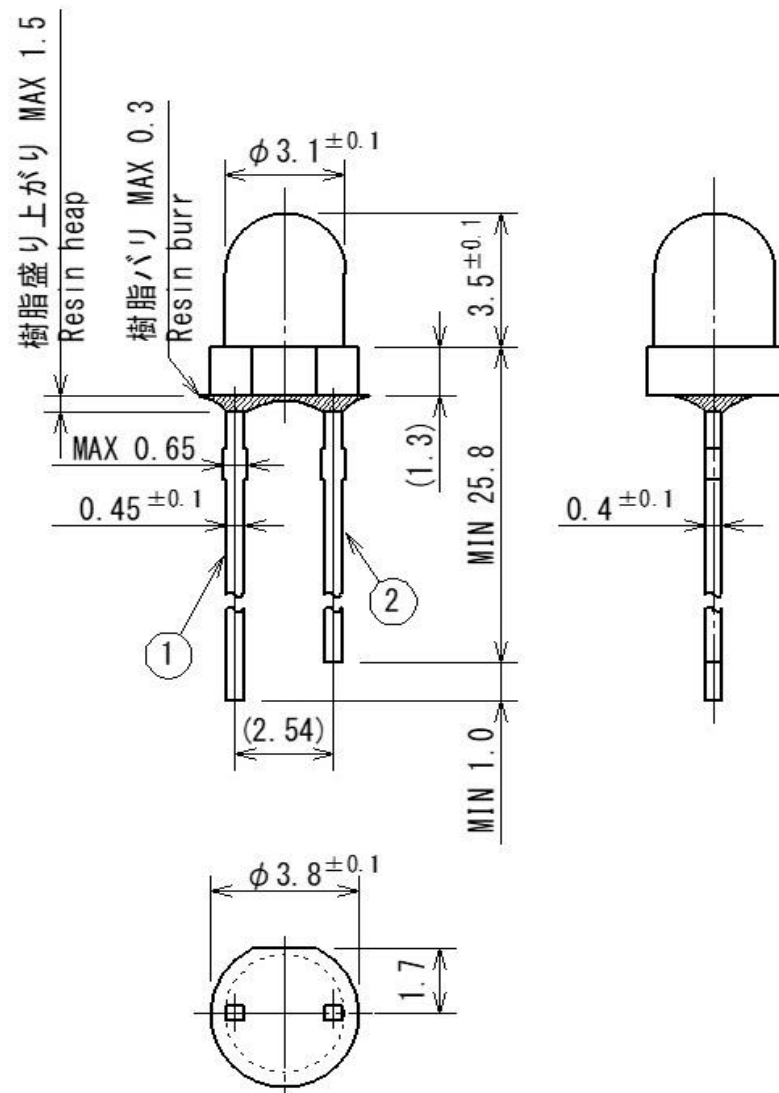

(Unit:mm)

Terminal: ①Anode
②Cathode

Tolerance: ±0.3

Material & Finish of leads

Material	Fe + Under Plating
Finish	Solder(Sn-3.0Ag-0.5Cu)

Material of resin

Material	Epoxy
----------	-------

● Note

Avoid applying external force, stress, and excessive vibration to the resins and terminals at high temperature.

The glass transition temperature of epoxy resin used for the LED is approximately 120 ~ 130°C. At a temperature exceeding this limit, the coefficient of linear expansion of the resin doubles or more compared to that at normal temperature and the resin is softened.

If external force or stress is applied at that time, the terminal will move and it may cause a wire rupture.

Please be careful about the following when soldering.

After soldering, avoid applying external force, stress, and excessive vibration during cooling process until the LEDs cool down to normal temperature. (Same for products with terminal leads)

① Soldering measurements:

Distance between melted solder side to bottom of resin shall be 5.5 mm or longer .

② Solder dip: Preheat: 90°C max. (Backside of PCB), Within 120 seconds

Solder bath: 250°C max. (Solder temperature), Within 5 seconds

③ Soldering iron: 350°C max. (Temperature of soldering iron tip), Within 3 seconds

When SMD components are used on the same PCB, mount the LED after adhesive baking process since the resin used for the LED has a low heat resistance.

In case the adhesive baking is operated after the LED is mounted for a manufacturing process reason, make sure not to apply external force, stress, and excessive vibration to the LED and follow the conditions below.

Baking temperature: 120°C max. Baking time: Within 60 seconds

When operating sequential soldering after the adhesive baking, perform the soldering after the LED cools down to normal temperature.

Pitch of the LED leads and pitch of mounting holes need to be the same.

Recommend following PCB for contact mount LEDs.

Recommended PCB : Single-faced PCBs with thickness 1.6mm & holes diameter ϕ 0.9 to 1.0mm

Do not use through holes type when using double-faced PCBs.

When doing the automatic insertion, maximize the clinch angle on the anode side of the LED so excessive remain force won't happen.

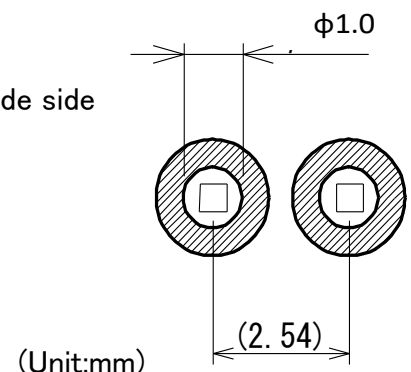

● Reliability test

	Test Items	EIAJ ED-4701	Test Conditions
Life Tests	Steady state operating life	–	Ta=RT , Ifmax t=1000h
Environ-mental Tests	Hight temperature storage	201	Ta=Tstgmax t=1000h
	Low temperature storage	202	Ta=Tstgmin t=1000h
	Moisture Resistance	103	Ta=60±5°C , RH=90±5% t=1000h
	Temperature cycle	105	Tstgmin(30min)~Tstgmax(30min) 100cycles
	Soldering heat	301/302	T=260±5°C , t=10s , 1time
	Solderraibility	303	T=245±5°C , t=5±1s,1time Using flux for Pb free solder
	Terminal strength(pull)	401	Loading weight 5N t=10s
	Terminal strength(bend)	401	Loading weight 2.5N 0 → 90° → 0
Drop	–	H=1m ,Drop on maple board .	

● Measurement Item and Criterion Judge Failure

No	Measurement Item	Mark	Criterion Judge Failure
1	Forward Voltage	VF	$OK \leq V.F.S. \times \pm 20\%$
2	Reverse Current	IR	$OK \geq U.S.L. \times 2.0$
3	Luminous Intensity	Iv	$OK \geq I.V.S. \times 0.5$

*Solderability … The Lead shall be covered by solder at least 95%.

Measurement cnditions is based on specifications.

Tstgmax and Tstgmin is abosolute maximum ratings.

IFmax and IFPmax is absolute maximum ratings,

U.S.L. is upper limit of standard.

V.F.S. is Initial data of VF.

I.V.S. is Initial data of Luminous Intensity.

● Packing specifications

Smallest packing

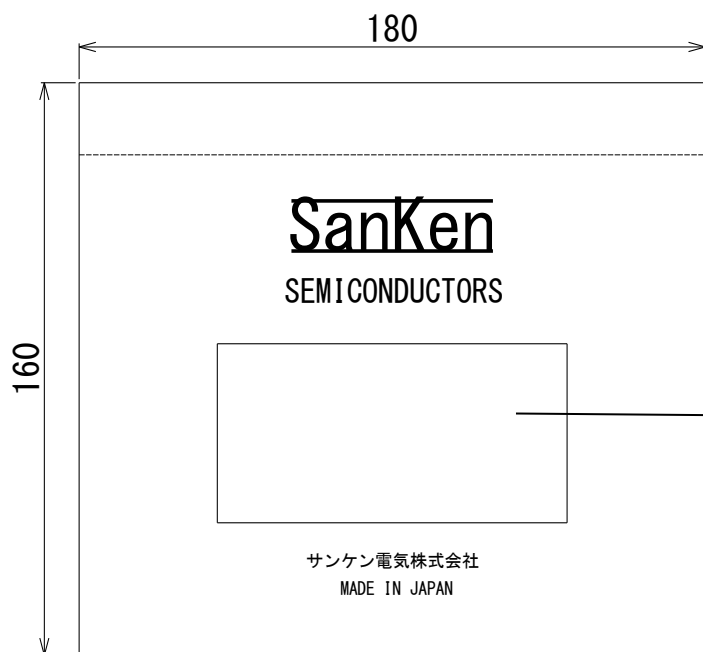

Packing material : Individual vinyl bag
Quantity(Minimum Order Quantity) : 1000pcs

Label : Label of below in the bag

(Unit:mm)

Label

Means Pb Free

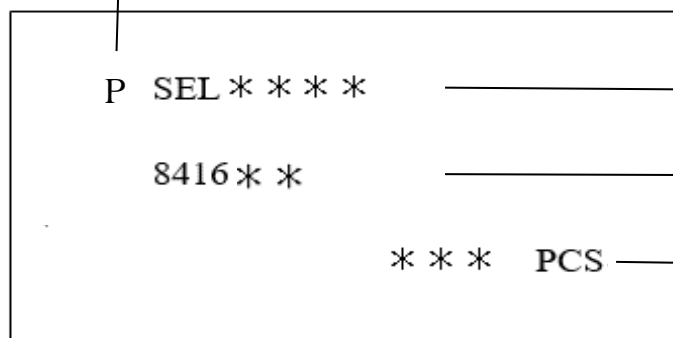

PART NUMBER

Lot No 8 4 16 **
 ① ② ③ ④

⑤

- ① Last digit of year
- ② Month
January~September→Arabic Numeral
October →O、November→N、December→D
- ③ Day
- ④ Luminous intensity rank / Chromaticity rank
- ⑤ Quantity(Minimum Order Quantity) : 1000pcs

● Taping specification for taped parts

Perforation and part number identification shall be placed as shown in the below.
As to the direction of feed, cathode shall come first.

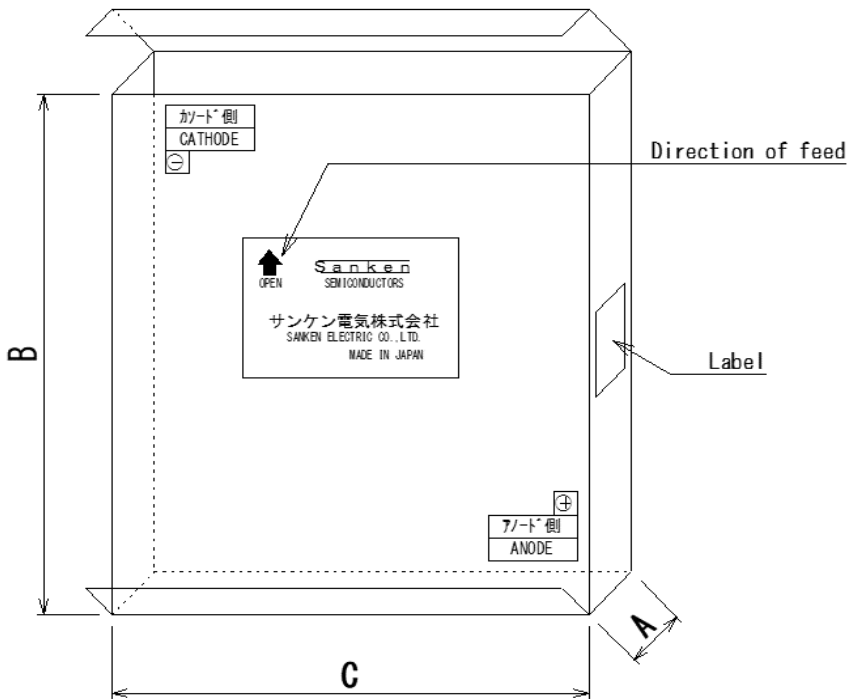

Outline drawing

Dimensions

A	54.5
B	365
C	335
Thickness	3.0

(Unit:mm)

Quantity(Minimum Order Quantity)
: 4000pcs

Label : Label of below in the bag

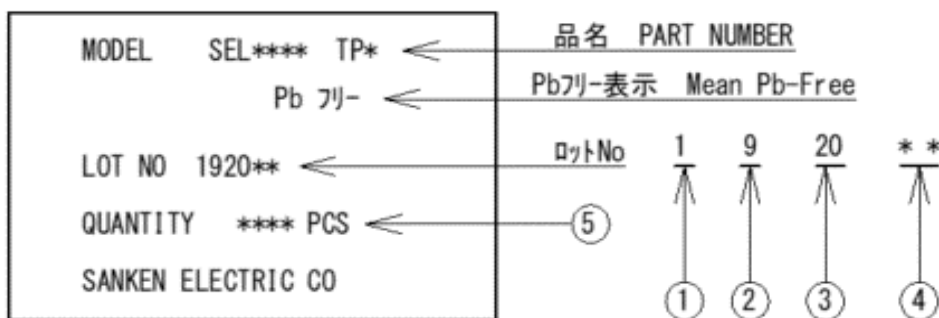

- ① Last digit of year
- ② Month
January ~ September → Arabic Numeral
October → O, November → N, December → D
- ③ Day
- ④ Luminous intensity rank / Chromaticity rank
- ⑤ Quantity(Minimum Order Quantity) : 4000pcs

● Taping specification

1. Forming type

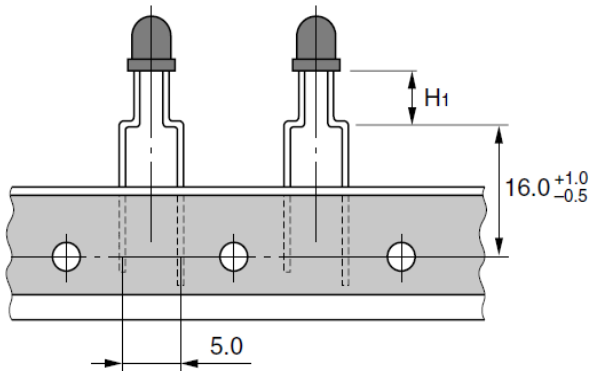

2. Straight type

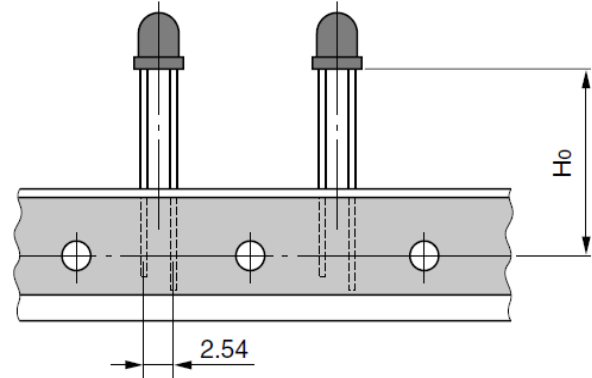

(Unit:mm)

Series	Forming type					
Taping name	TP1	TP2	TP3	TP6	TP7	TP8
Size H1	4.5	7.5	6.0	3.5	5.0	9.0
SELU2410C-TG	○	○	○	○	○	○

Series	Straight type					
Taping name	TP4	TP5	TP15	TP16	TP17	TP18
Size H0	17.0	20.5	20.0	19.0	23.5	25.0
SELU2410C-TG	×	×	×	×	×	×

● TP1 Outline dimensions

Component Alignment

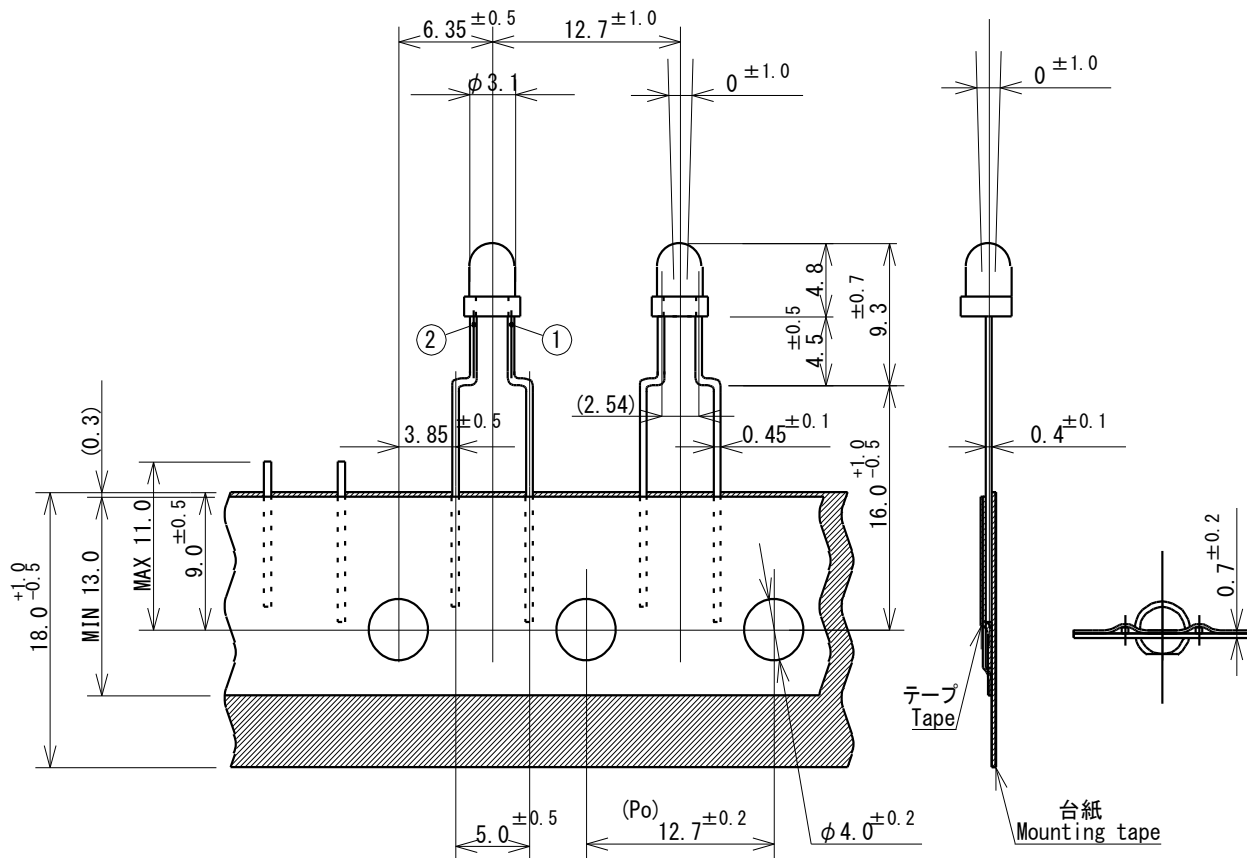

(Unit:mm)

(Po):Cumulative pitch tolerance shall not exceed $±1.0$ mm over 20 consecutive pitches.

Terminal: ①Anode
②Cathode

Tolerance: $±0.3$

● TP2 Outline dimensions

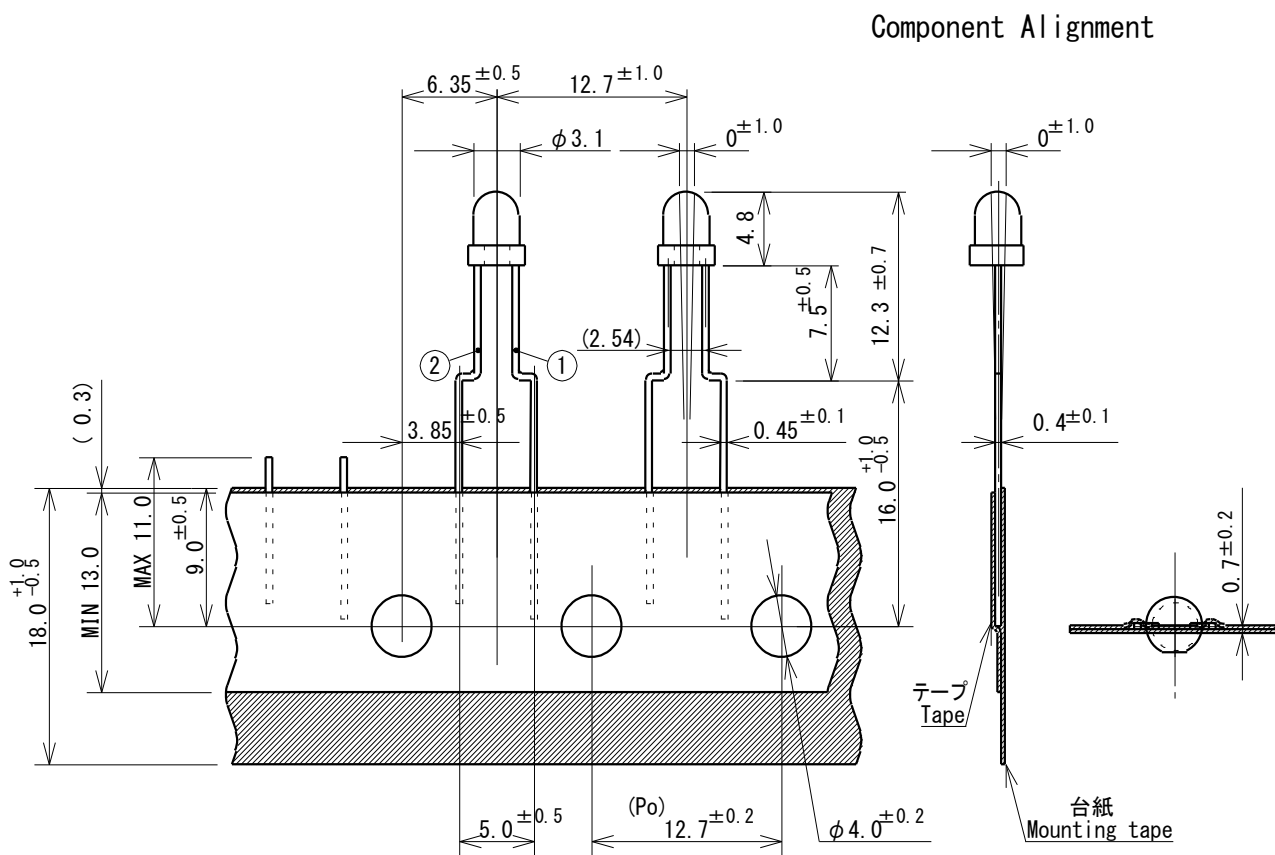

(Unit:mm)

(Po):Cumulative pitch tolerance shall not exceed ± 1.0 mm over 20 consecutive pitches.

Terminal: ①Anode
②Cathode

Tolerance: ± 0.3

● TP3 Outline dimensions

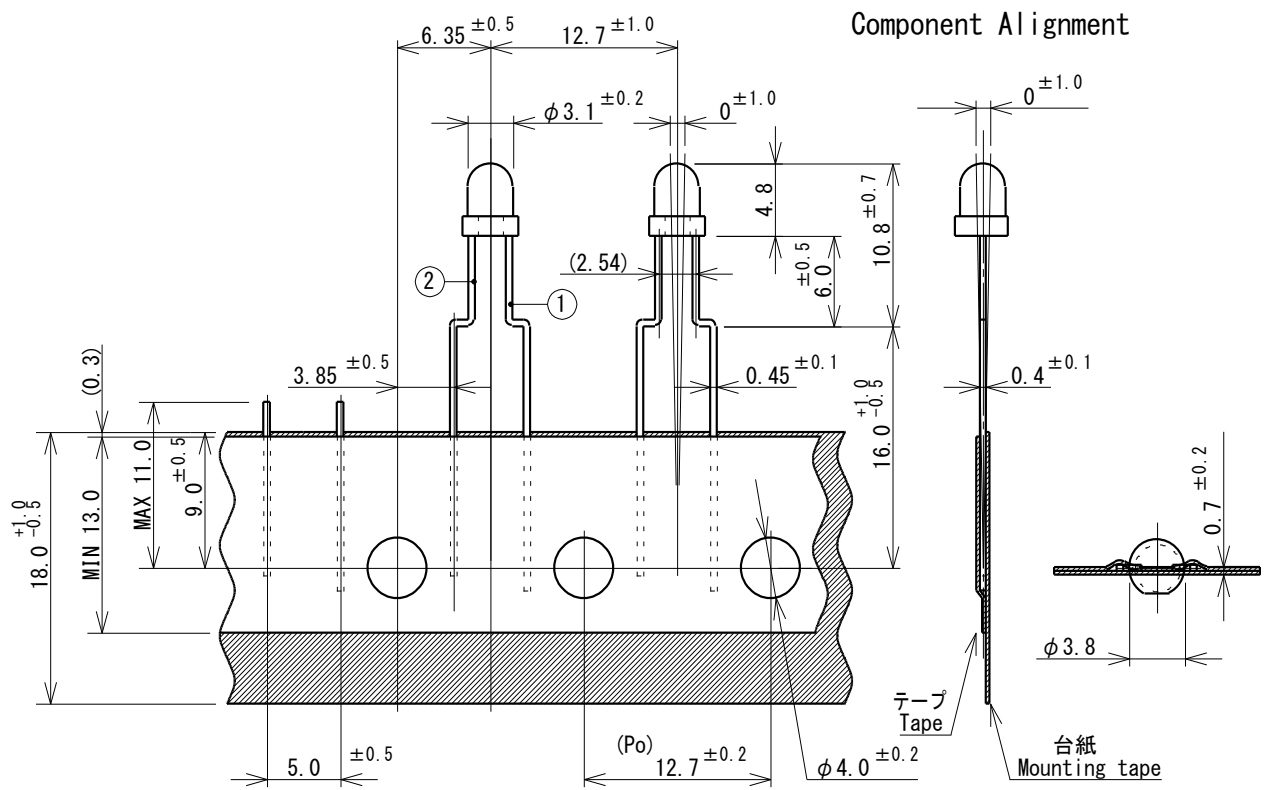

(Unit:mm)

(Po):Cumulative pitch tolerance shall not exceed $±1.0$ mm over 20 consecutive pitches.

Terminal: ①Anode
②Cathode

Tolerance: $±0.3$

● TP6 Outline dimensions

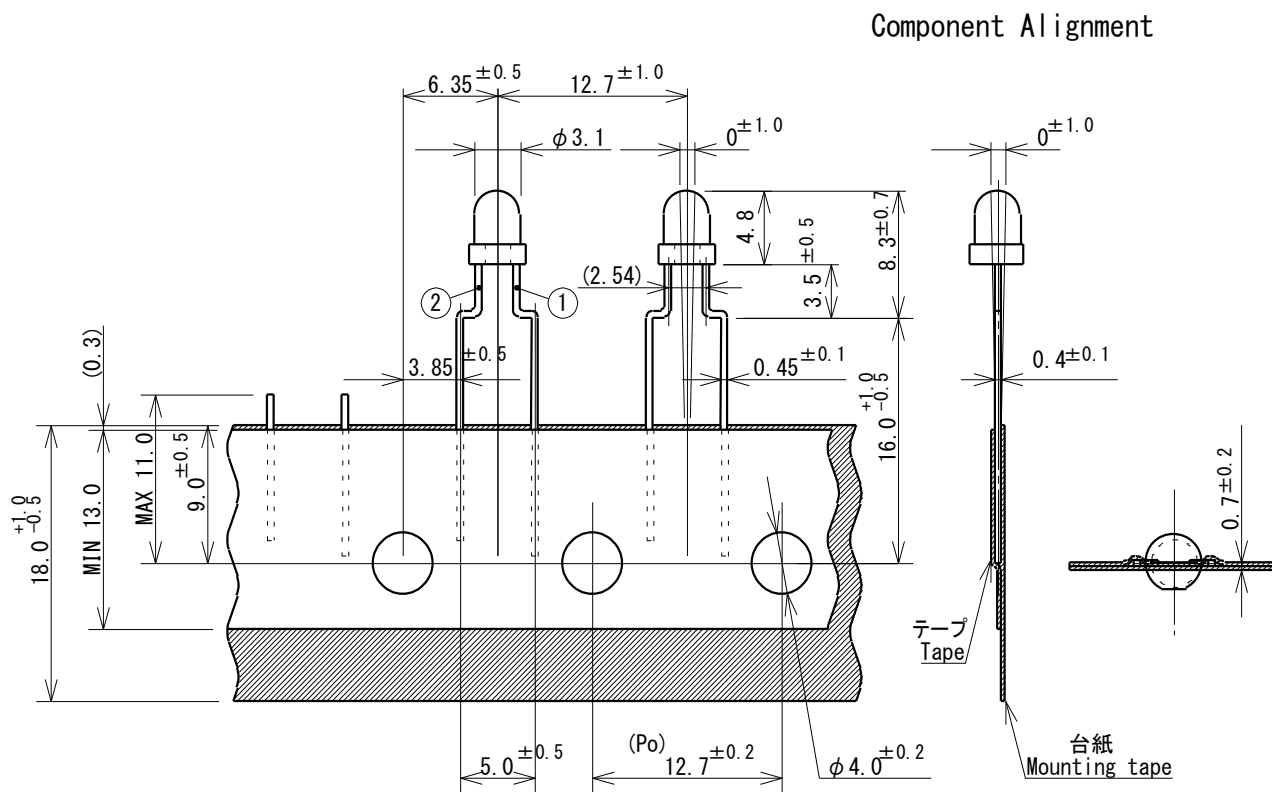

(Unit:mm)

(Po):Cumulative pitch tolerance shall not exceed $\pm 1.0\text{mm}$ over 20 consecutive pitches.

Terminal: ①Anode
②Cathode

Tolerance: ± 0.3

● TP7 Outline dimensions

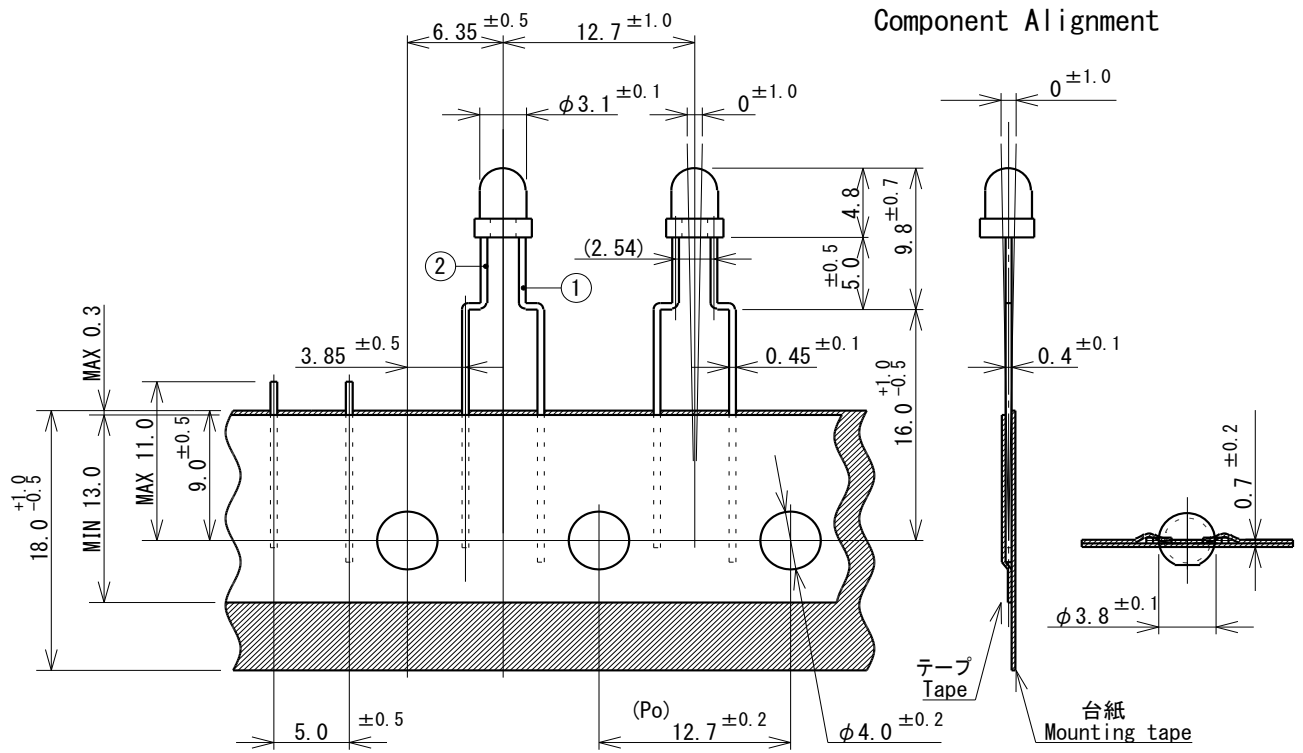

(Unit:mm)

(Po):Cumulative pitch tolerance shall not exceed $\pm 1.0\text{mm}$ over 20 consecutive pitches.

Terminal: ①Anode
②Cathode

Tolerance: ± 0.3

● TP8 Outline dimensions

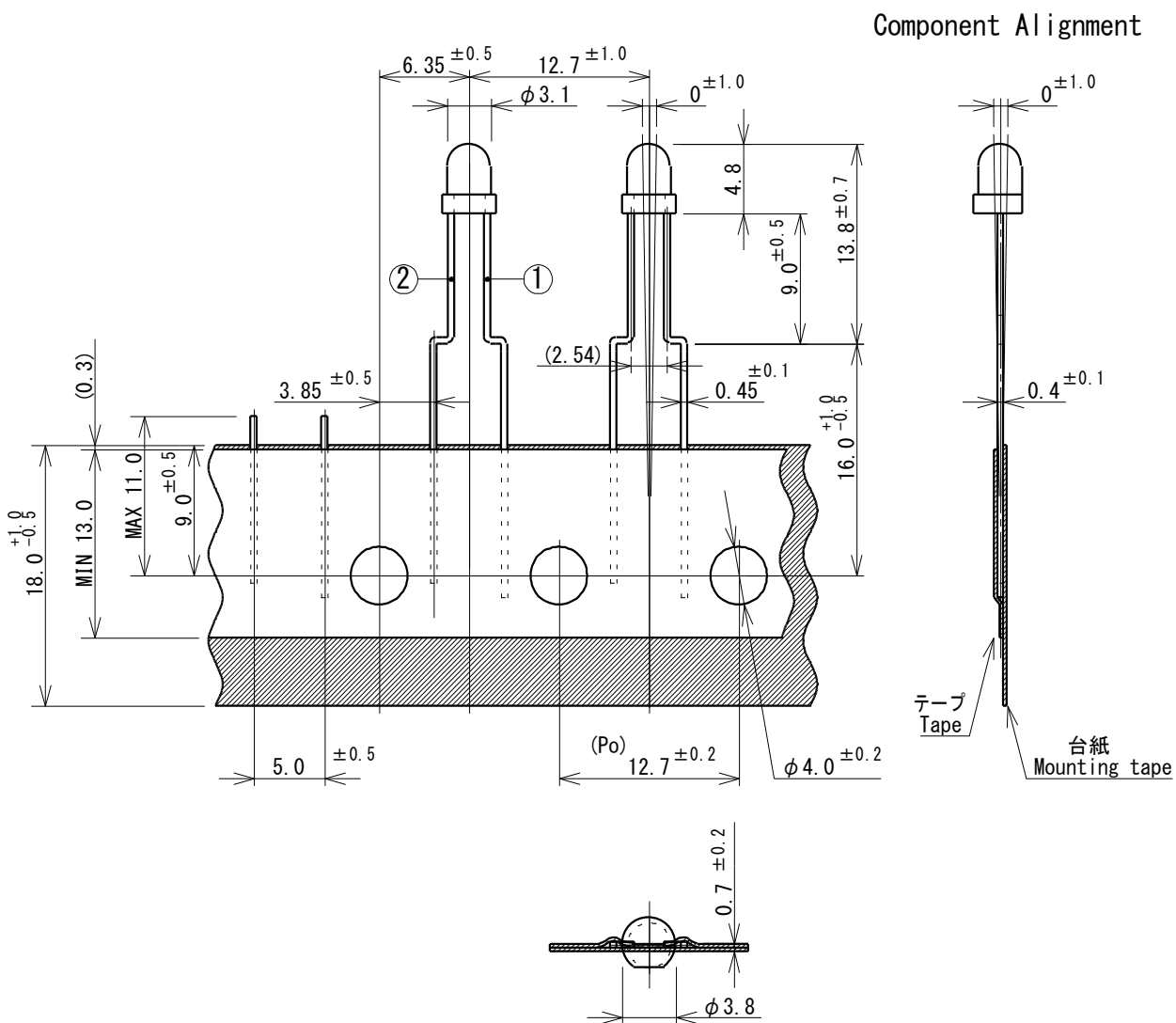

(Unit:mm)

(Po):Cumulative pitch tolerance shall not exceed $\pm 1.0\text{mm}$ over 20 consecutive pitches.

Terminal: ①Anode
②Cathode

Tolerance: ± 0.3

Important Notes

- All data, illustrations, graphs, tables and any other information included in this document as to SanKen's products listed herein (the "SanKen Products") are current as of the date this document is issued. All contents in this document are subject to any change without notice due to improvement of the SanKen Products, etc. Please make sure to confirm with a SanKen sales representative that the contents set forth in this document reflect the latest revisions before use.
- The SanKen Products are intended for use as components of electronic equipment or apparatus (transportation equipment and its control systems, home appliances, office equipment, telecommunication equipment, measuring equipment, etc.). Prior to use of the SanKen Products, please put your signature, or affix your name and seal, on the specification documents of the SanKen Products and return them to SanKen. If considering use of the SanKen Products for any applications that require higher reliability (traffic signal control systems or equipment, disaster/crime alarm systems, etc.), you must contact a SanKen sales representative to discuss the suitability of such use and put your signature, or affix your name and seal, on the specification documents of the SanKen Products and return them to SanKen, prior to the use of the SanKen Products. The SanKen Products are not intended for use in any applications that require extremely high reliability such as: aerospace equipment; nuclear power control systems; and medical equipment or systems, whose failure or malfunction may result in death or serious injury to people, i.e., medical devices in Class III or a higher class as defined by relevant laws of Japan (collectively, the "Specific Applications"). SanKen assumes no liability or responsibility whatsoever for any and all damages and losses that may be suffered by you, users or any third party, resulting from the use of the SanKen Products in the Specific Applications or in manner not in compliance with the instructions set forth herein.
- In the event of using the SanKen Products by either (i) combining other products or materials therewith or (ii) physically, chemically or otherwise processing or treating the same, you must duly consider all possible risks that may result from all such uses in advance and proceed therewith at your own responsibility.
- Although SanKen is making efforts to enhance the quality and reliability of its products, it is impossible to completely avoid the occurrence of any failure or defect in semiconductor products at a certain rate. You must take, at your own responsibility, preventative measures including using a sufficient safety design and confirming safety of any equipment or systems in/for which the SanKen Products are used, upon due consideration of a failure occurrence rate or derating, etc., in order not to cause any human injury or death fire accident or social harm which may result from any failure or malfunction of the SanKen Products.
- No anti-radioactive ray design has been adopted for the SanKen Products.
- Gallium arsenic is used in some of the products listed in this document. These products are dangerous if they are burned or smashed in the process of disposal. It is also dangerous to drink the liquid or inhale the gas generated by such products when chemically disposed.
- No contents in this document can be transcribed or copied without SanKen's prior written consent.
- The circuit constant, operation examples, circuit examples, pattern layout examples, design examples, recommended examples, all information and evaluation results based thereon, etc., described in this document are presented for the sole purpose of reference of use of the SanKen Products and SanKen assumes no responsibility whatsoever for any and all damages and losses that may be suffered by you, users or any third party, or any possible infringement of any and all property rights including intellectual property rights and any other rights of you, users or any third party, resulting from the foregoing.
- All technical information described in this document (the "Technical Information") is presented for the sole purpose of reference of use of the SanKen Products and no license, express, implied or otherwise, is granted hereby under any intellectual property rights or any other rights of SanKen.
- Unless otherwise agreed in writing between SanKen and you, SanKen makes no warranty of any kind, whether express or implied, including, without limitation, any warranty (i) as to the quality or performance of the SanKen Products (such as implied warranty of merchantability, or implied warranty of fitness for a particular purpose or special environment), (ii) that any SanKen Product is delivered free of claims of third parties by way of infringement or the like, (iii) that may arise from course of performance, course of dealing or usage of trade, and (iv) as to any information contained in this document (including its accuracy, usefulness, or reliability).
- In the event of using the SanKen Products, you must use the same after carefully examining all applicable environmental laws and regulations that regulate the inclusion or use of any particular controlled substances, including, but not limited to, the EU RoHS Directive, so as to be in strict compliance with such applicable laws and regulations.
- You must not use the SanKen Products or the Technical Information for the purpose of any military applications or use, including but not limited to the development of weapons of mass destruction. In the event of exporting the SanKen Products or the Technical Information, or providing them for non-residents, you must comply with all applicable export control laws and regulations in each country including the U.S. Export Administration Regulations (EAR) and the Foreign Exchange and Foreign Trade Act of Japan, and follow the procedures required by such applicable laws and regulations.
- SanKen assumes no responsibility for any troubles, which may occur during the transportation of the SanKen Products including the falling thereof, out of SanKen's distribution network.
- Although SanKen has prepared this document with its due care to pursue the accuracy thereof, SanKen does not warrant that it is error free and SanKen assumes no liability whatsoever for any and all damages and losses which may be suffered by you resulting from any possible errors or omissions in connection with the contents included herein.
- Please refer to the relevant specification documents in relation to particular precautions when using the SanKen Products.
- All rights and title in and to any specific trademark or tradename belong to SanKen or such original right holder(s).