

SEED TECHNOLOGY INC (SEEEDUINO)

Grove - Line Finder

Model: SEN21177P

Introduction

Line finder Grove is designed for line following robotic. It consists two parts - an IR emitting LED and an IR sensitive phototransistor. It can output digital signal to a microcontroller so the robot can reliably follow a black line on a white background, or vice versa.

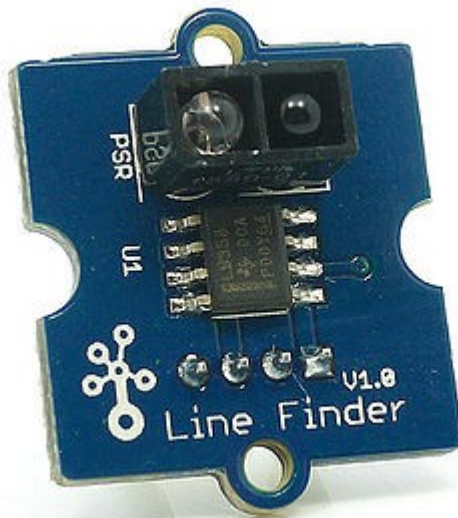

Structure overview

Comparator: MV358

MV358 is used as voltage comparator.

>>Datasheet:

<http://www.xyk-ic.com/product-details.asp?id=16858>

Photo reflective diode: RS-06WD

RS-06WD is designed to detect surface color.

>>Datasheet:

<http://www.waitrony.com/eng/>

Features

- Grove compatible interface
- Small size
- 5V DC power supply
- Indicator LED
- Digital output
- Distance adjustable

Application Ideas

- Tracking line

- Robotic

Cautions

The warnings and wrong operations possible cause dangerous.

Schematic

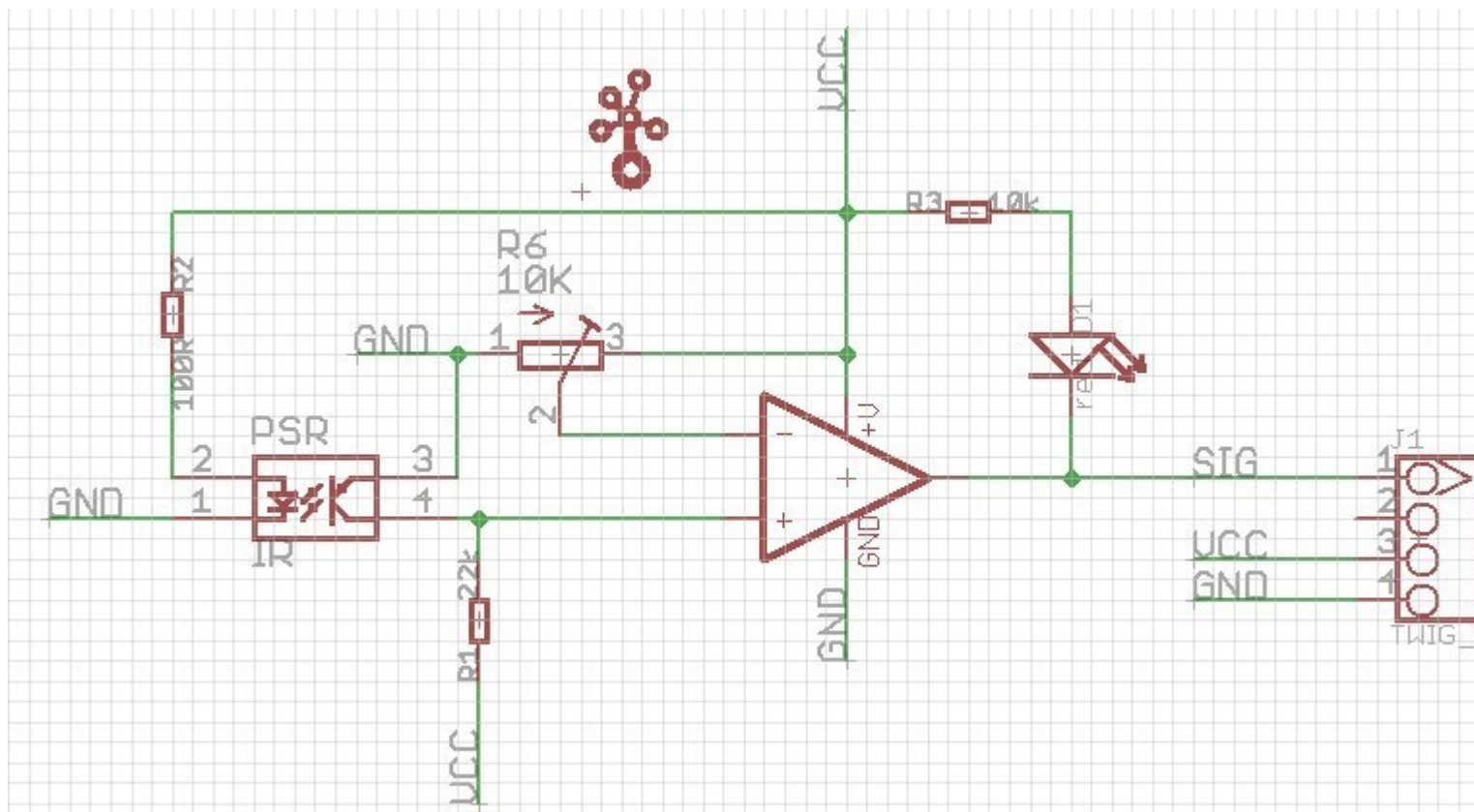

Specification

Key Specification

Indicator LED	Red (lighten shows black line detected, ignore it in analog mode)
Power supply	5V DC
Digital output mode	TTL (High when black is detected, Low when white is detected)
Connector	4 pin Buckled Grove interface
Connectivity	Compatible with Arduino
Dimension	20mm*20mm
ROHS	YES

Pin definition and Rating

Pad Type	Pin Status	Description
GND	Input	Ground port
SIG	Output	TTL
NC	NC	NC
VCC	Input	3.3V - 5V

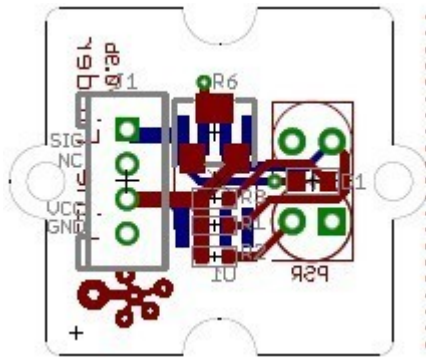

Dimension: 2cm x 2cm

Usage

Hardware Installation

The brick will return HIGH when black line is detected, and LOW when white line is detected. Using the adjustable resistor the detection range can be changed from 1.5cm to 5cm. If the sensor can't tell between black and white surfaces, you can also use the adjustable resistor to set a suitable reference voltage.

Programming

Includes important code snippet. Demo code like :

```
Demo code
{
//-----
//Name: Line finder digital mode
//Function: detect black line or white line
//Parameter:  When digital signal is HIGH, black line
//             When digital signal is LOW, white line
//-----
int signalPin = 3;    // connected to digital pin 3
void setup()  {
  pinMode(signalPin, INPUT); // initialize the digital pin as an output:
  Serial.begin(9600); // initialize serial communications at 9600 bps:
}
// the loop() method runs over and over again,
// as long as the Arduino has power
void loop()
{
  if(HIGH == digitalRead(signalPin))
    Serial.println("black");
  else Serial.println("white"); // display the color
    //delay(1000); // wait for a second
}
}
```

Example

The projects and application examples.

Bill of Materials (BOM) /parts list

All the components used to produce the product.

Please list your question here:

Support

If you have questions or other better design ideas, you can go to our [forum](#) or [wish](#) to discuss.

Version Tracker

	Revision	Descriptions	Release
v0.9b		Initial public release	Aug 11, 2010

Bug Tracker

Bug Tracker is the place you can publish any bugs you think you might have found during use. Please write down what you have to say, your answers will help us improve our products.

Additional Idea

The Additional Idea is the place to write your project ideas about this product, or other usages you've found. Or you can write them on Projects page.

Licensing

This documentation is licensed under the Creative Commons [Attribution-ShareAlike License 3.0](#) Source code and libraries are licensed under [GPL/LGPL](#), see source code files for details.