

$\Phi_V = 25.7 \text{ lm}$, $V_F = 2.8 \text{ V}$
High Color Rendering Index, Surface Mount LED
SEP1YN1L72



Preliminary

Data Sheet

Description

The SEP1YN1L72 is a surface mount LED with a color temperature of white (5000K). Having high color rendering index, the product is suitable for LED lighting systems including general-illumination applications and showcases.

Features

- Color ----- White (5000K)
- Luminous Flux, Φ_V ----- 25.7 lm (typ.) ($I_F = 65 \text{ mA}$)
- Forward Voltage, V_F ----- 2.8 V (typ.) ($I_F = 65 \text{ mA}$)
- Chromaticity (x, y) ----- (0.3447, 0.3553)
- Color Rendering Index, Ra ----- 93
- Viewing Angle, $2\theta_{1/2}$ ----- 120 deg
- MSL 3
- RoHS Compliant
- Pb-free, Reflow Soldering
- High Reliability

Applications

LED lighting for industrial equipment, houses, and facilities, such as:

- Showcase for Foods
- Spotlight
- LED Tube
- Ceiling Light
- Downlight

Package

Dimensions (L × W × H): 2.8 × 3.5 × 0.7 mm

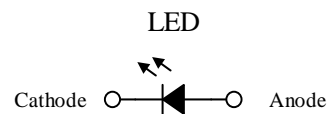

Not to scale

Absolute Maximum Ratings

Unless specifically noted, $T_A = 25\text{ }^\circ\text{C}$.

Parameter	Symbol	Conditions	Rating	Unit
Allowable Power Dissipation	P_D		465	mW
Forward Current	I_F		150	mA
Reverse Voltage	V_R		3	V
Operating Temperature ⁽¹⁾	T_{OP}	⁽²⁾	-40 to 85	$^\circ\text{C}$
Storage Temperature ⁽¹⁾	T_{STG}	⁽²⁾	-40 to 100	$^\circ\text{C}$
Junction Temperature	T_J		115	$^\circ\text{C}$

Electrical / Optical Characteristics

Unless specifically noted, $T_A = 25\text{ }^\circ\text{C}$.

Parameter	Symbol	Conditions	Min.	Typ.	Max.	Unit
Forward Voltage	V_F	$I_F = 65\text{ mA}$	2.7	2.8	3.1	V
Reverse Current	I_R	$V_R = 3\text{ V}$	—	—	10	μA
Luminous Flux	Φ_V	$I_F = 65\text{ mA}$	23.1	25.7	29.6	lm
Chromaticity	x	$I_F = 65\text{ mA}$	—	0.3447	—	—
	y		—	0.3553	—	—
Color Rendering Index ⁽³⁾	Ra	$I_F = 65\text{ mA}$	90	93	—	—
Viewing Angle	$2\theta_{1/2}$	$I_F = 65\text{ mA}$	—	120	—	deg
Junction-to-Solder Point Thermal Resistance	$\theta_{(J-S)}$	⁽²⁾	—	25	—	$^\circ\text{C/W}$

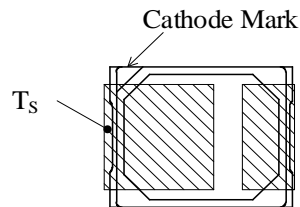

Figure 1. T_S Measurement Point

⁽¹⁾ Determined by the solder point temperature, T_S .

⁽²⁾ Solder point temperature, T_S , is defined by land pattern of cathode side (see Figure 1).

⁽³⁾ Allows a measurement tolerance of ± 2 .

Luminous Flux Bins

The values have a tolerance of $\pm 10\%$.

Bin Number	Luminous Flux Range	Unit
3	23.1 to 24.4	lm
4	24.4 to 25.7	lm
5	25.7 to 27.0	lm
6	27.0 to 28.3	lm
7	28.3 to 29.6	lm

V_F Bins

The values have a tolerance of $\pm 3\%$.

Bin Number	V _F Range	Unit
1	2.7 to 2.8	V
2	2.8 to 2.9	V
3	2.9 to 3.0	V
4	3.0 to 3.1	V

Chromaticity Bins

Figure 2 is the chromaticity diagram plotting chromaticity bins, with a tolerance of ± 0.01 .

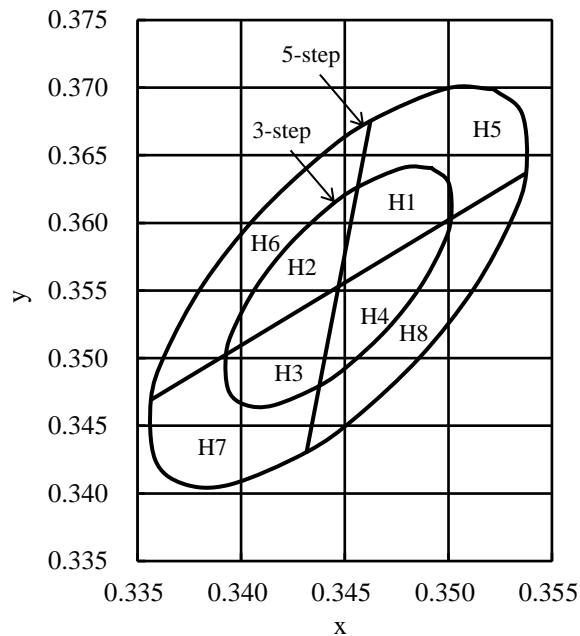

Table 1. Chromaticity Diagram: Region and Coordinates

Parameter	MacAdam Ellipse	
	3-step	5-step
Chromaticity Center Coordinate, x	0.3447	
Chromaticity Center Coordinate, y	0.3553	
Ellipse Major Axis	0.009840	0.016399
Ellipse Minor Axis	0.003584	0.005974
Rotation Angle, θ	62.808°	

Figure 2. Chromaticity Diagram

Derating Curves

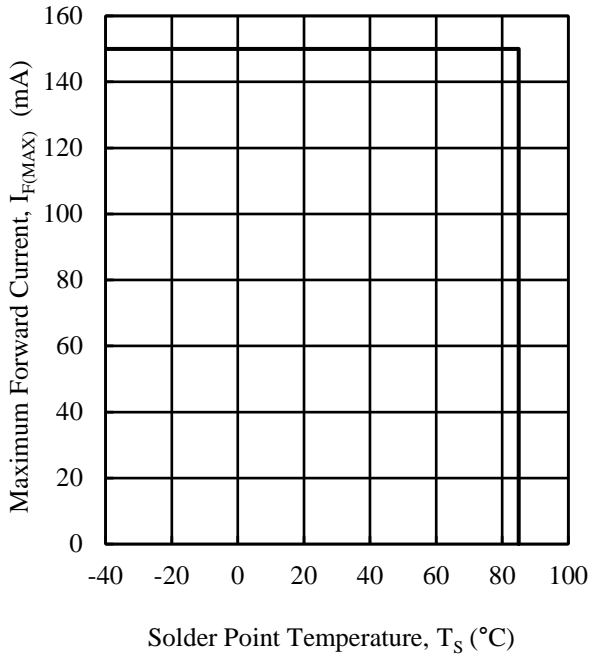

Figure 3. $I_{F(MAX)}$ vs. T_S

Characteristic Curves

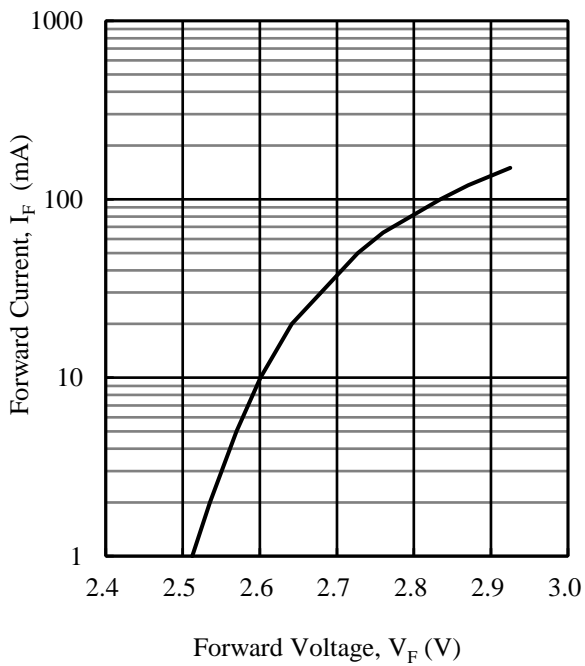

Figure 4. I_F vs. V_F ($T_A = 25\text{ °C}$)

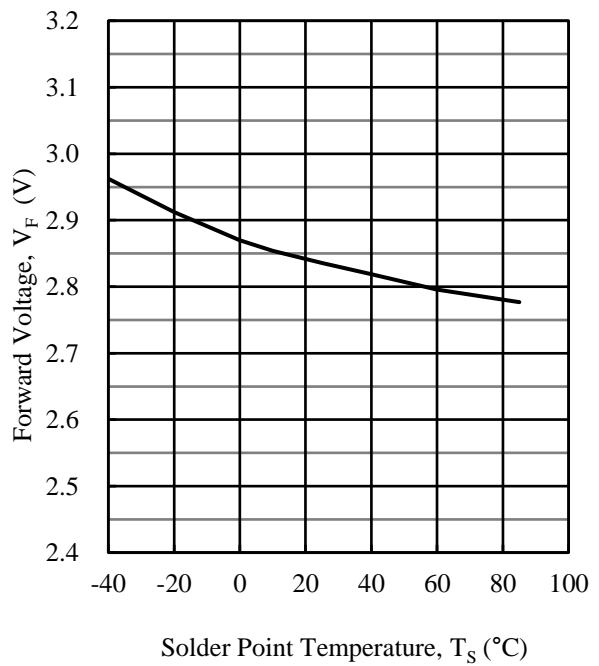

Figure 5. V_F vs. T_S ($I_F = 65\text{ mA}$)

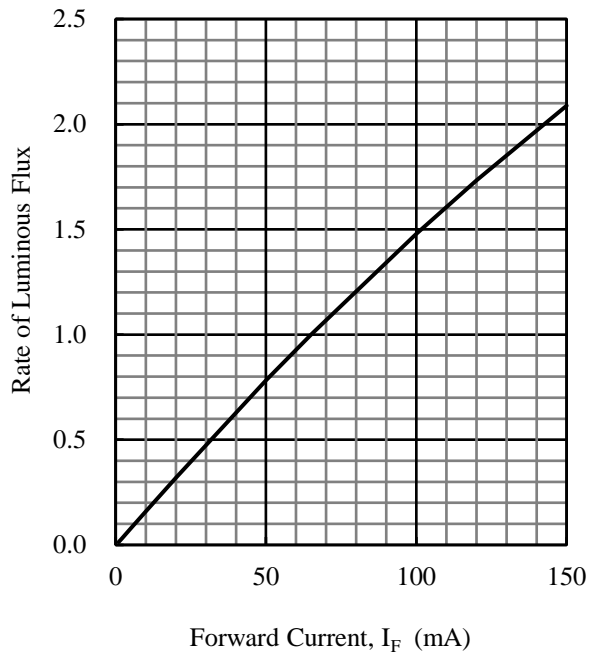

Figure 6. Rate of Luminous Flux vs. I_F ($T_A = 25\text{ °C}$)

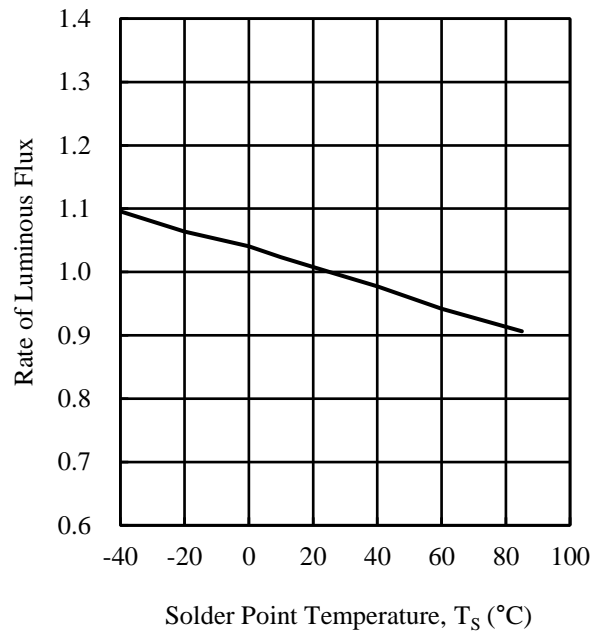

Figure 7. Rate of Luminous Flux vs. T_S ($I_F = 65\text{ mA}$)

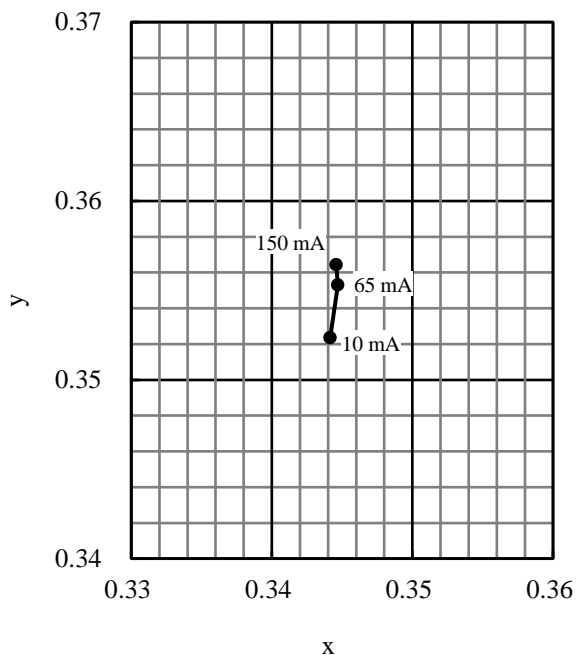

Figure 8. I_F vs. Chromaticity ($T_A = 25\text{ °C}$)

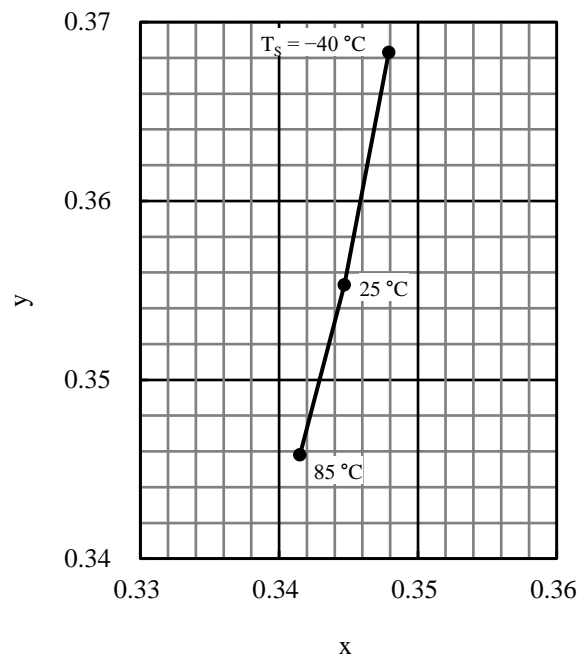

Figure 9. T_S vs. Chromaticity ($I_F = 65\text{ mA}$)

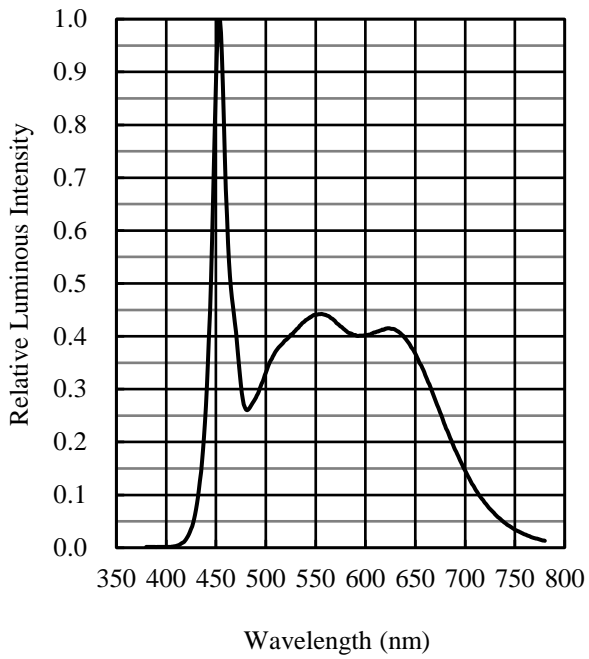

Figure 10. Spectrum ($T_A = 25\text{ }^\circ\text{C}$, $I_F = 65\text{ mA}$)

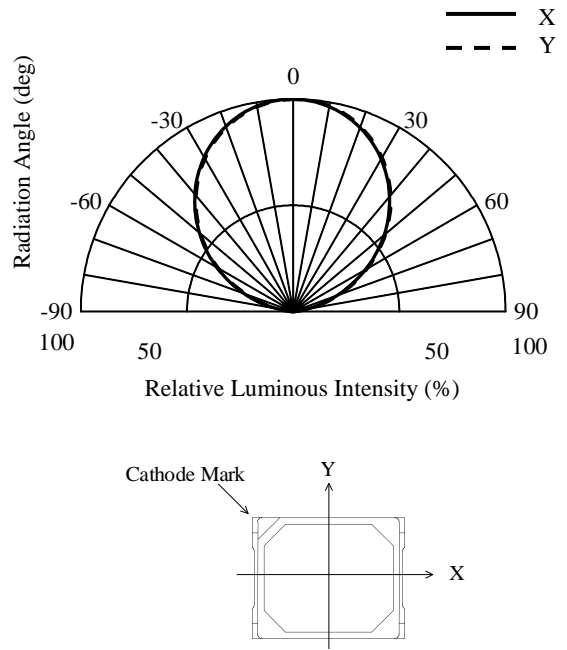
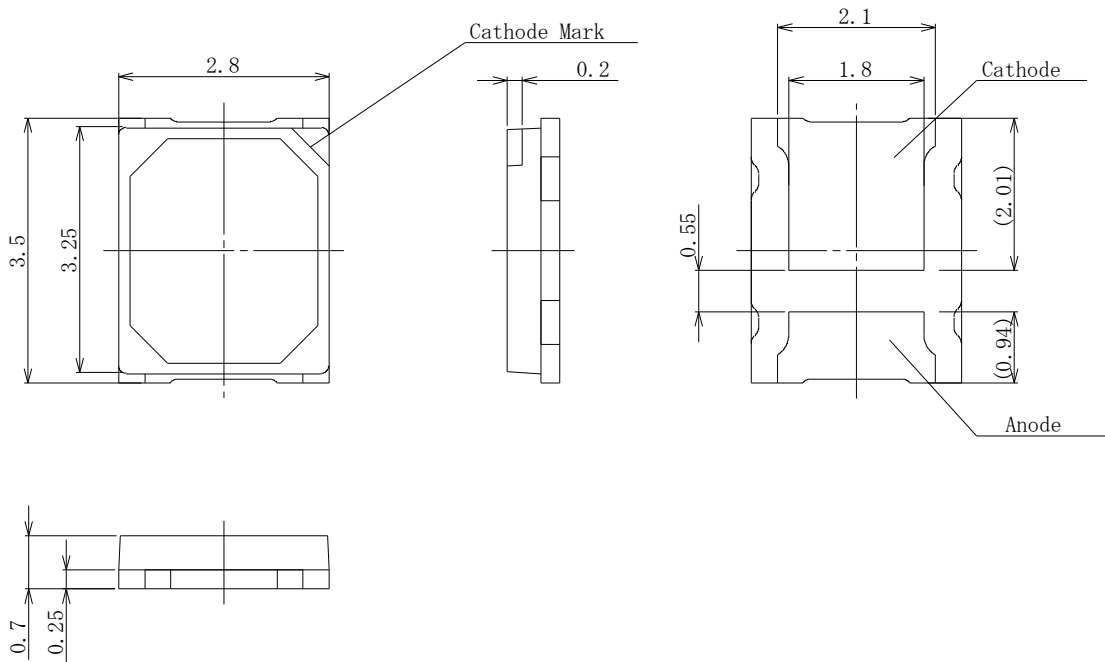

Figure 11. Directivity ($T_A = 25\text{ }^\circ\text{C}$, $I_F = 65\text{ mA}$)

SEP1YN1L72

Physical Dimensions

• Surface Mount (2.8 × 3.5 × 0.7 mm)



NOTES:

- Dimensions in millimeters
- Tolerance: ± 0.2 mm
- All the values in parentheses are reference dimensions.
- Pb-free (RoHS compliant)
- MSL 3 (Moisture Sensitivity Level 3)

• Land Pattern Example

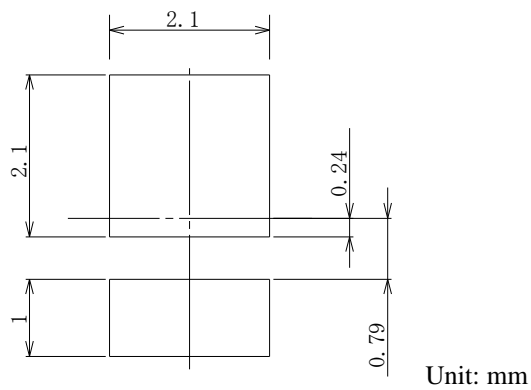

Soldering Conditions

When soldering the products, it is required to minimize the working time within the following limits:

- Reflow:
 - Preheat: 150 to 180 °C / 60 to 120 s
 - Solder heating: 220 °C / 40 s (260 °C peak, 2 times)
- Soldering Iron: 350 ±10 °C, 3 s, 1 time

● Reference Reflow Profile

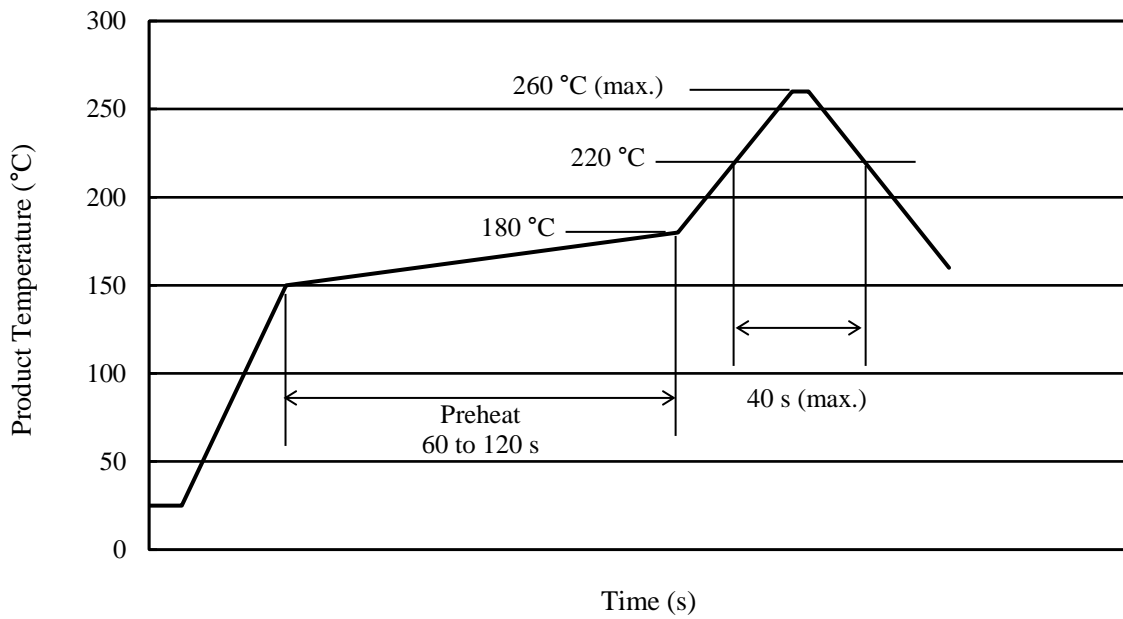

Precautions for Use

• Measures for Electrostatic Discharge (ESD)

Because this device is sensitive to ESD, it is necessary to take adequate measures against ESD and surge for safe and proper handling. In particular, note that when a voltage that exceeds the absolute maximum rating is applied, the device may be damaged.

• Reference Protection Circuits for Electrostatic Discharge and Surge

The following figures show reference protection circuits that prevent the device from any damage due to ESD or surge. Note that these circuits are only examples; therefore, be sure to check the ESD and surge levels in your actual system and to take appropriate measures (e.g., adding a part) as needed.

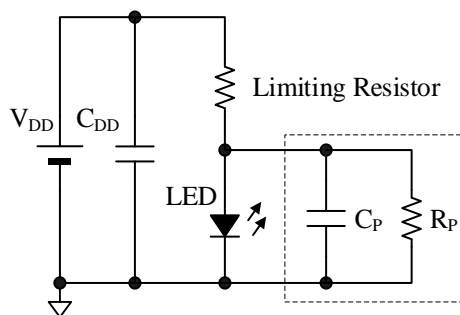

Example of Adding Filter
($C_P \geq 0.01 \mu\text{F}$, $R_P = 10 \text{ k}\Omega$)

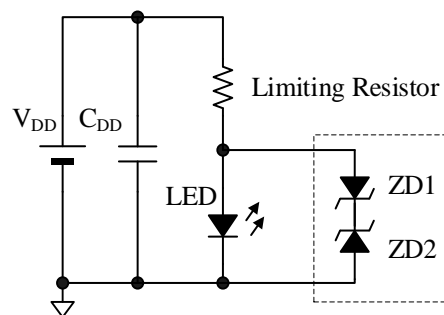

Example of Adding Zener Diodes
(ZD1, ZD2: $V_Z = 7 \text{ V to } 8 \text{ V}$)

• Others

- After soldering the device, care should be taken not to apply mechanical stress or excessive vibration until it cools to room temperature.
- Do not cool the device rapidly.
- When mounting the device on a board, mounting position and orientation should be taken into account so that any stress due to board warpage is not applied to the device.
- Do not touch the encapsulating resin of the device with sharp objects such as a tweezer or fingernails. Also, do not use the device again after removal.
- Do not touch the device after mounting it on a board.
- The device emits a high-power light. Therefore, care should be taken not to look at the light emission directly for a long time because it may hurt your eyes.
- Use the device at rated current (sorting current) as much as possible. When the device is used at a current lower than the rated current (sorting current), a variation in forward voltage or luminous intensity may increase. Therefore, care should be taken for such variation when you use the device at low current.
- When the device comes into contact with material containing sulfide or is exposed to an atmosphere containing sulfide gas, the following may be caused: discoloration in the silver plating of the metal parts inside and outside the package; change in the brightness and tint of the original luminescent color.

Important Notes

- All data, illustrations, graphs, tables and any other information included in this document (the “Information”) as to Sanken’s products listed herein (the “Sanken Products”) are current as of the date this document is issued. The Information is subject to any change without notice due to improvement of the Sanken Products, etc. Please make sure to confirm with a Sanken sales representative that the contents set forth in this document reflect the latest revisions before use.
- The Sanken Products are intended for use as components of general purpose electronic equipment or apparatus (such as home appliances, office equipment, telecommunication equipment, measuring equipment, etc.). Prior to use of the Sanken Products, please put your signature, or affix your name and seal, on the specification documents of the Sanken Products and return them to Sanken. When considering use of the Sanken Products for any applications that require higher reliability (such as transportation equipment and its control systems, traffic signal control systems or equipment, disaster/crime alarm systems, various safety devices, etc.), you must contact a Sanken sales representative to discuss the suitability of such use and put your signature, or affix your name and seal, on the specification documents of the Sanken Products and return them to Sanken, prior to the use of the Sanken Products. The Sanken Products are not intended for use in any applications that require extremely high reliability such as: aerospace equipment; nuclear power control systems; and medical equipment or systems, whose failure or malfunction may result in death or serious injury to people, i.e., medical devices in Class III or a higher class as defined by relevant laws of Japan (collectively, the “Specific Applications”). Sanken assumes no liability or responsibility whatsoever for any and all damages and losses that may be suffered by you, users or any third party, resulting from the use of the Sanken Products in the Specific Applications or in manner not in compliance with the instructions set forth herein.
- In the event of using the Sanken Products by either (i) combining other products or materials or both therewith or (ii) physically, chemically or otherwise processing or treating or both the same, you must duly consider all possible risks that may result from all such uses in advance and proceed therewith at your own responsibility.
- Although Sanken is making efforts to enhance the quality and reliability of its products, it is impossible to completely avoid the occurrence of any failure or defect or both in semiconductor products at a certain rate. You must take, at your own responsibility, preventative measures including using a sufficient safety design and confirming safety of any equipment or systems in/for which the Sanken Products are used, upon due consideration of a failure occurrence rate and derating, etc., in order not to cause any human injury or death, fire accident or social harm which may result from any failure or malfunction of the Sanken Products. Please refer to the relevant specification documents and Sanken’s official website in relation to derating.
- No anti-radioactive ray design has been adopted for the Sanken Products.
- The circuit constant, operation examples, circuit examples, pattern layout examples, design examples, recommended examples, all information and evaluation results based thereon, etc., described in this document are presented for the sole purpose of reference of use of the Sanken Products.
- Sanken assumes no responsibility whatsoever for any and all damages and losses that may be suffered by you, users or any third party, or any possible infringement of any and all property rights including intellectual property rights and any other rights of you, users or any third party, resulting from the Information.
- No information in this document can be transcribed or copied or both without Sanken’s prior written consent.
- Regarding the Information, no license, express, implied or otherwise, is granted hereby under any intellectual property rights and any other rights of Sanken.
- Unless otherwise agreed in writing between Sanken and you, Sanken makes no warranty of any kind, whether express or implied, including, without limitation, any warranty (i) as to the quality or performance of the Sanken Products (such as implied warranty of merchantability, and implied warranty of fitness for a particular purpose or special environment), (ii) that any Sanken Product is delivered free of claims of third parties by way of infringement or the like, (iii) that may arise from course of performance, course of dealing or usage of trade, and (iv) as to the Information (including its accuracy, usefulness, and reliability).
- In the event of using the Sanken Products, you must use the same after carefully examining all applicable environmental laws and regulations that regulate the inclusion or use or both of any particular controlled substances, including, but not limited to, the EU RoHS Directive, so as to be in strict compliance with such applicable laws and regulations.
- You must not use the Sanken Products or the Information for the purpose of any military applications or use, including but not limited to the development of weapons of mass destruction. In the event of exporting the Sanken Products or the Information, or providing them for non-residents, you must comply with all applicable export control laws and regulations in each country including the U.S. Export Administration Regulations (EAR) and the Foreign Exchange and Foreign Trade Act of Japan, and follow the procedures required by such applicable laws and regulations.
- Sanken assumes no responsibility for any troubles, which may occur during the transportation of the Sanken Products including the falling thereof, out of Sanken’s distribution network.
- Although Sanken has prepared this document with its due care to pursue the accuracy thereof, Sanken does not warrant that it is error free and Sanken assumes no liability whatsoever for any and all damages and losses which may be suffered by you resulting from any possible errors or omissions in connection with the Information.
- Please refer to our official website in relation to general instructions and directions for using the Sanken Products, and refer to the relevant specification documents in relation to particular precautions when using the Sanken Products.
- All rights and title in and to any specific trademark or tradename belong to Sanken and such original right holder(s).

DSGN-CEZ-16003