

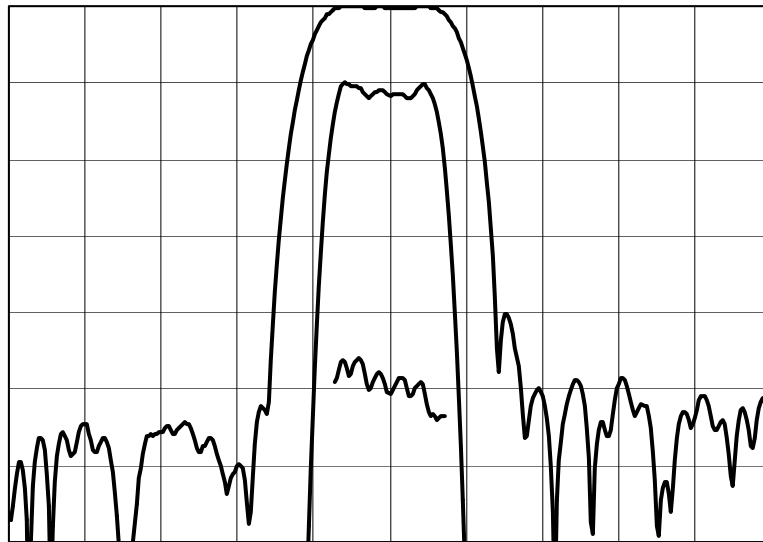

TYPICAL PERFORMANCE



Horizontal: 1.5 MHz/div

Vertical (from top):

Magnitude	10	dB/div
Magnitude	1	dB/div
Group Delay Deviation	70	ns/div

SPECIFICATION

Operating Temperature = 25 °C

Parameter	Min	Typ	Max	Units
Center Frequency ¹	349.9	350	350.1	MHz
Insertion Loss at 350 MHz		14	15	dB
0.5 dB Bandwidth ²	1.7	2.1		MHz
3 dB Bandwidth ²	2.6	2.7		MHz
20 dB Bandwidth ²		3.9	4	MHz
45 dB Bandwidth ²		4.9	6	MHz
Group Delay Variation, 348.9 – 351.1 MHz		60	70	ns
Source Impedance		50		Ω
Load Impedance		50		Ω
Substrate Material	Quartz			
Temperature Sensitivity of Frequency	$\Delta F/F_0 = -[(T-T_0)/5.4]^2$			

Notes: 1. Mean of the 3dB frequencies, with dB defined relative to the response peak.
2. dB levels defined relative to the insertion loss at 350 MHz.



PACKAGE OUTLINE

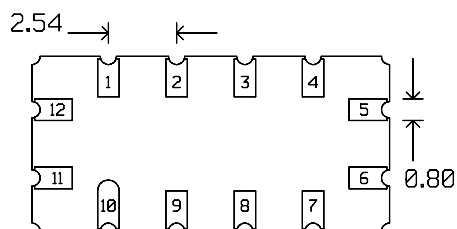
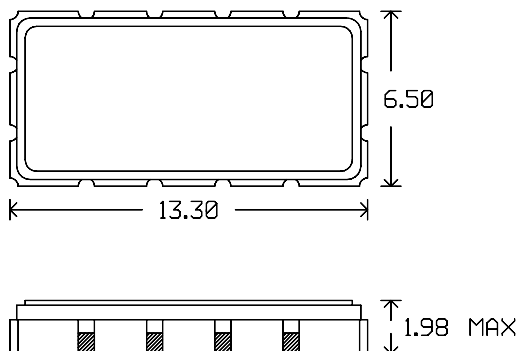

Units: mm

Pin Configuration:

Input:	11
Input Return:	12
Output:	5
Output Return:	6
Ground:	1,2,3,4,7,8,9,10

MATCHING CIRCUIT

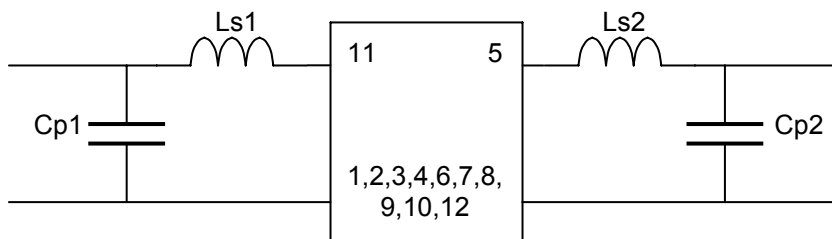

Component values used in the Micro Networks test fixture:

	Ls1 = 27 nH	Ls2 = 24 nH
(inductor Q = 45)	Cp1 = 33 pF	Cp2 = 22 pF

Notes:

1. Component values may change depending on board layout.
2. These component values were optimised for passband ripple.

ISO 9001
Registered