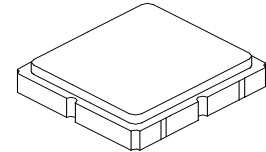

SF1183E

881.5 MHz SAW Filter

SM3030-6

- **RF Filter for Mobile Communication Applications**
- **Low Insertion Loss**
- **3.0 x 3.0 x 1.3 mm Surface-mount Case**
- **No Matching Circuit Required**

Absolute Maximum Ratings

Rating	Value	Units
Maximum Input Power	+10	dBm
Maximum DC Voltage	5	VDC
Operable Temperature Range	-45 to +125	°C
Specification Temperature Range	-30 to +85	°C
Storage Temperature Range	-40 to +85	°C
Max Soldering Profile	265 °C for 10 s	

Electrical Characteristics

Characteristic	Sym	Notes	Min	Typ	Max	Units
Nominal Operating Frequency	f_c	1	881.5			MHz
Insertion Loss, 869 to 894 MHz	IL			2.3	3.0	dB
Amplitude Ripple, p-p, 869 to 894 MHz				0.8	1.5	
Attenuation (Reference level from 0 dB)		1, 2, 3				dB
DC to 824 MHz			40	50		
824 to 849 MHz			35	47		
970 to 997 MHz			35	64		
997 to 1150 MHz			40	60		
1150 to 1500 MHz			30	51		
1500 to 2000 MHz			25	41		
2000 to 3000 MHz		20	27			
VSWR, 869 to 894 MHz				1.6:1	2.0:1	MHz
Source impedance	Z_S			50		Ω
Load impedance	Z_L			50		Ω

Single Ended Input / Output, Impedance match	No matching network required for operation at 50 ohms
Case Style	SM3030-6 3 x 3 mm Nominal Footprint
Lid Symbolization (Y=year, WW=week, S=day)	A92 YWWS

Electrical Connections

Connection	Terminals
Input	2
Output	5
Ground	All others

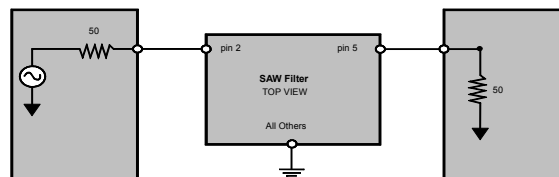
NOTES:

1. Unless noted otherwise, all specifications apply over the operating temperature range with filter soldered to the specified demonstration board with impedance matching to 50 Ω and measured with 50 Ω network analyzer.
2. Unless noted otherwise, all frequency specifications are referenced to the nominal center frequency, f_c .
3. Rejection is measured as attenuation below the minimum IL point in the pass-band. Rejection in final user application is dependent on PCB layout and external impedance matching design. See Application Note No. 42 for details.
4. "LRIP" or "L" after the part number indicates "low rate initial production" and

5. "ENG" or "E" indicates "engineering prototypes."
6. The design, manufacturing process, and specifications of this filter are subject to change.
7. Either Port 1 or Port 2 may be used for either input or output in the design. However, impedances and impedance matching may vary between Port 1 and Port 2, so that the filter must always be installed in one direction per the circuit design.
8. US and international patents may apply.
9. RFM, stylized RFM logo, and RF Monolithics, Inc. are registered trademarks of RF Monolithics, Inc.
10. Electrostatic Sensitive Device. Observe precautions for handling.

Filter Frequency Response Plots

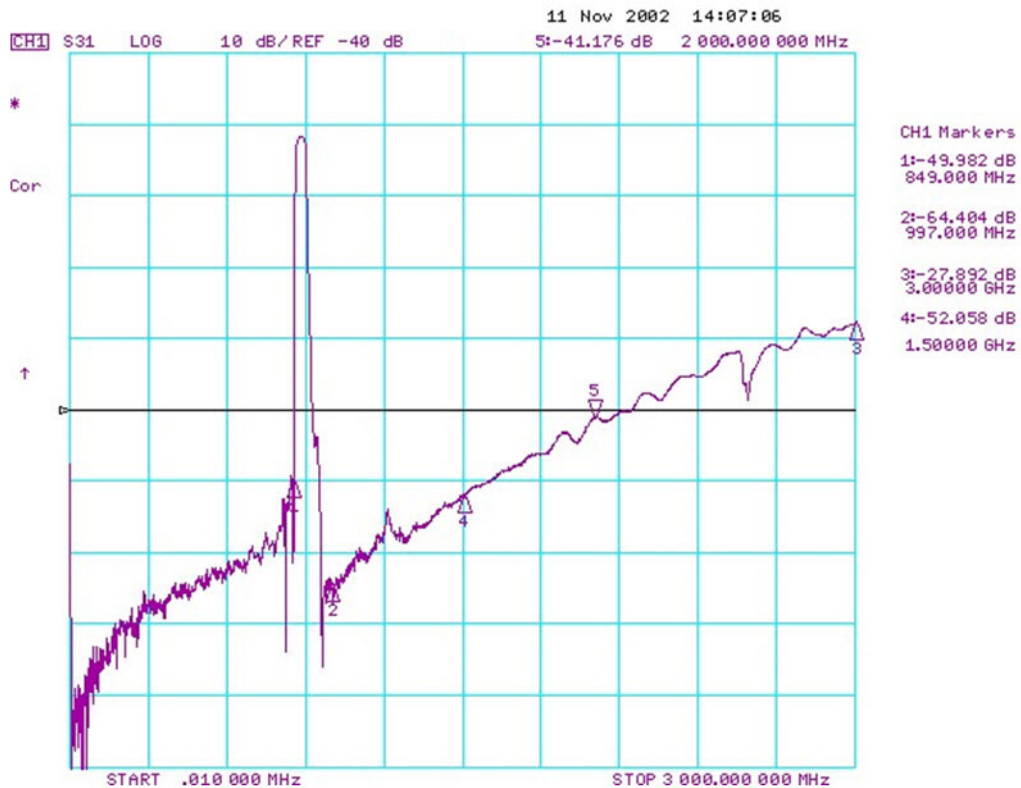
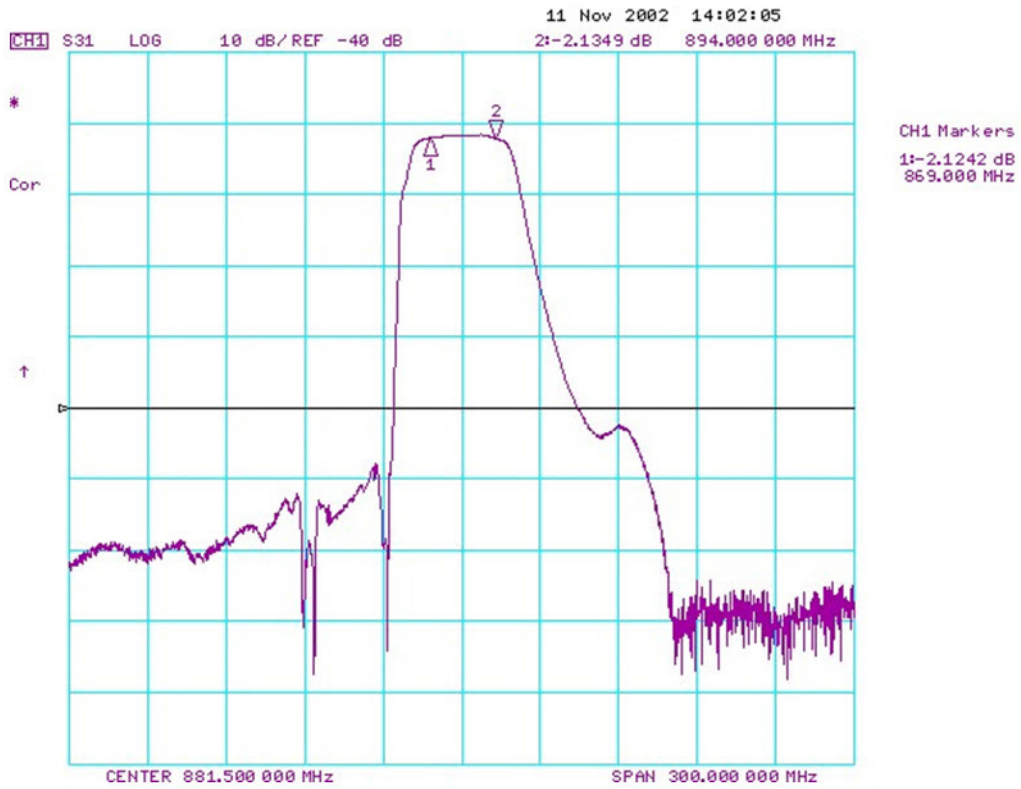

VSWR and Impedance Plots

S11

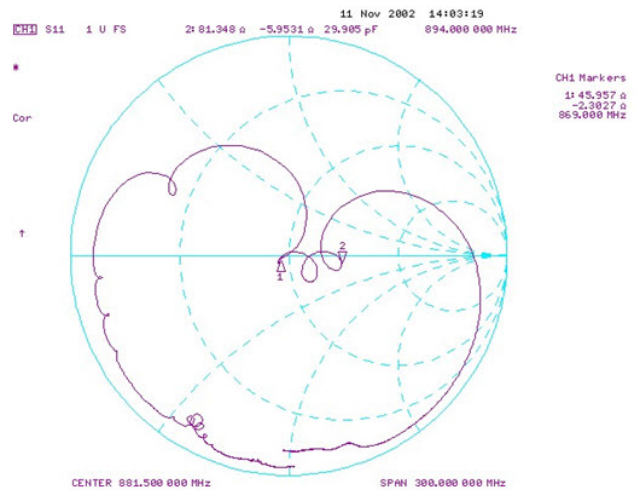
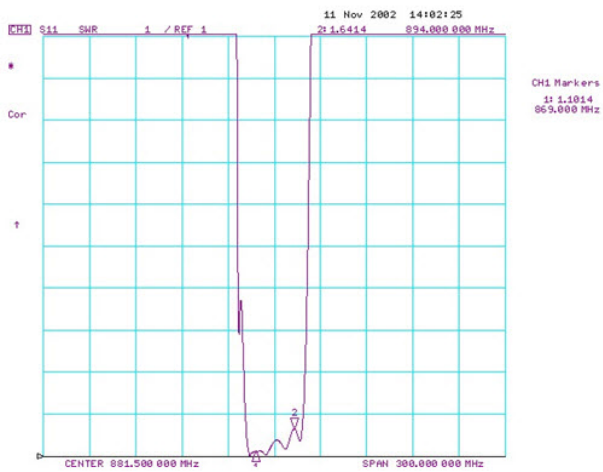

S22

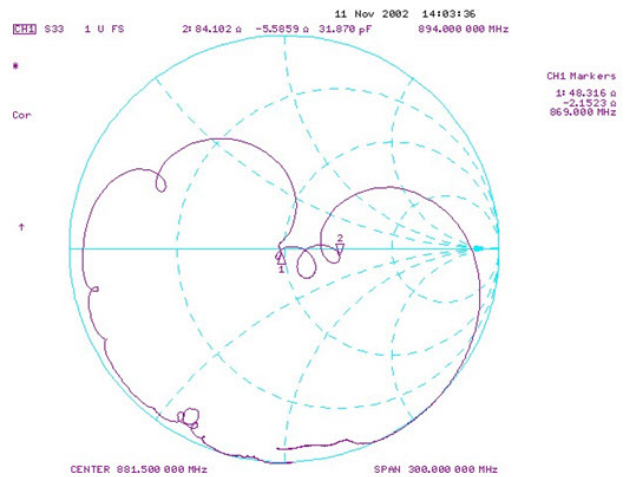
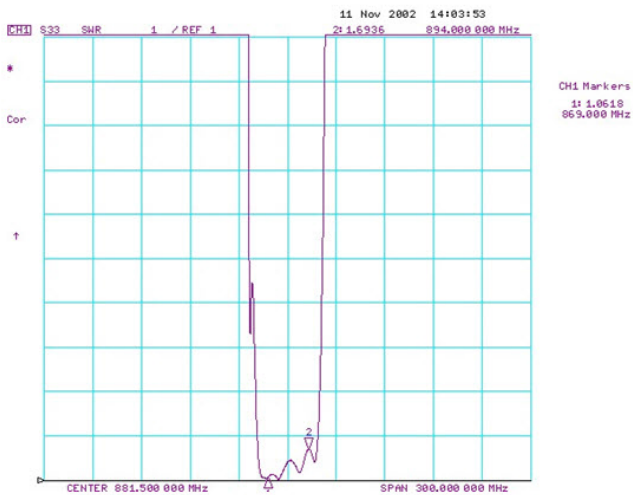

Tape and Reel Specifications

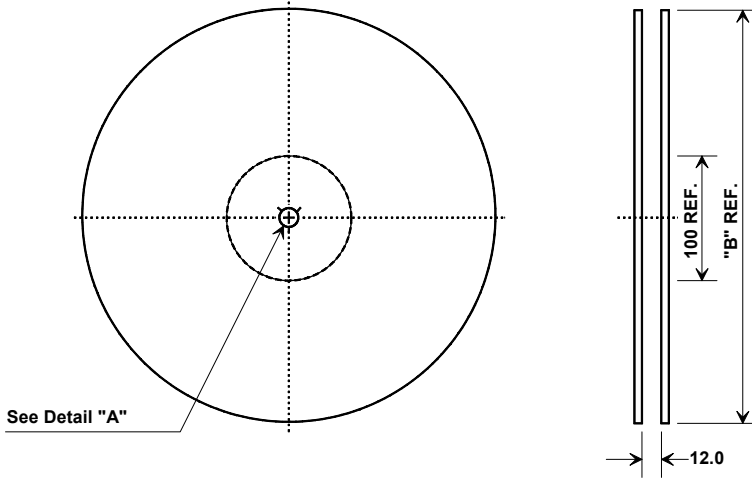

"B" Nominal Size		Quantity Per Reel
Inches	millimeters	
7	178	500
13	330	2000

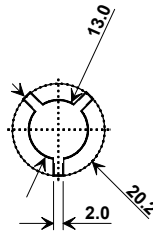

COMPONENT ORIENTATION

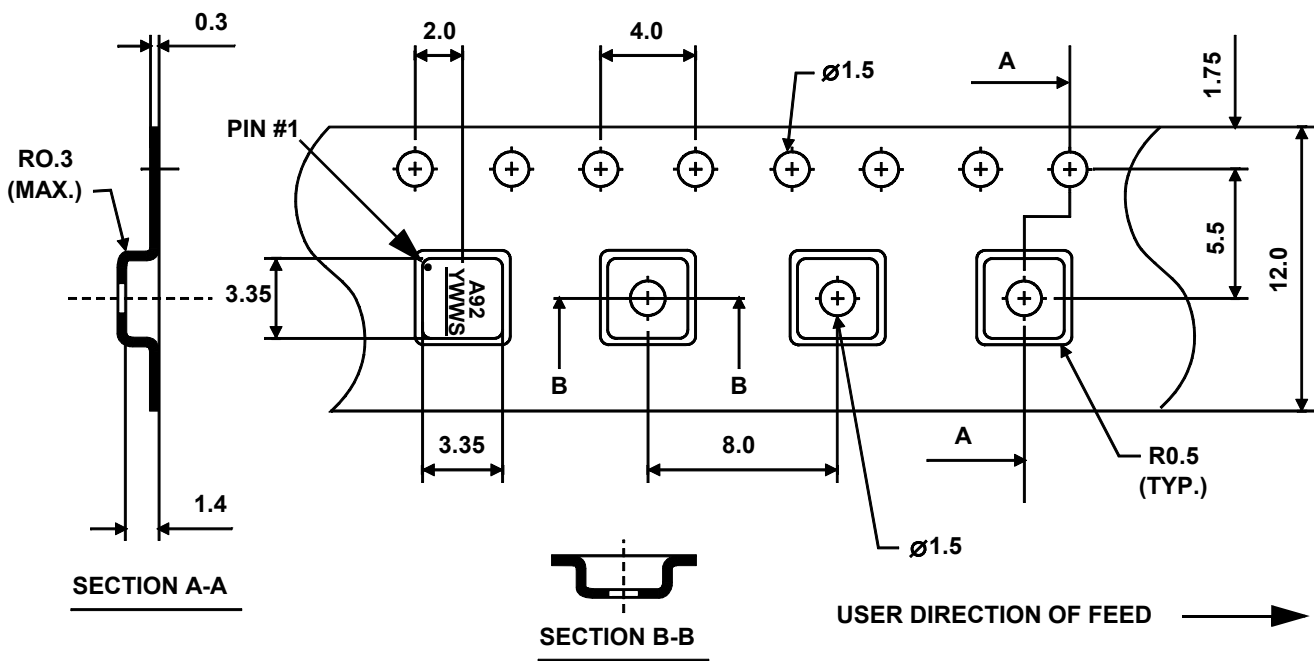

SM3030-6 Case

6-Terminal Ceramic Surface-Mount Case 3.0 X 3.0 mm Nominal Footprint

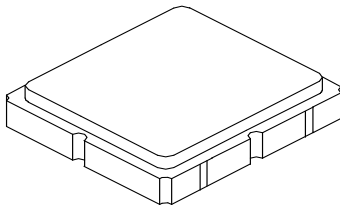

Case Dimensions

Dimension	mm			Inches		
	Min	Nom	Max	Min	Nom	Max
A		3.0			0.118	
B		3.0			0.118	
C		1.3			0.051	
D		0.9			0.035	
E		2.54			0.100	
F		1.6			0.063	
G		0.85			0.033	
H		1.5			0.059	
I		0.6			0.024	
J		1.3			0.051	

Connection		Terminals
Port 1	Single Ended Input	2
Port 2	Single Ended Output	5
	Ground	All others
Single-ended Operation Only		
Dot indicates Pin 1		

TOP VIEW

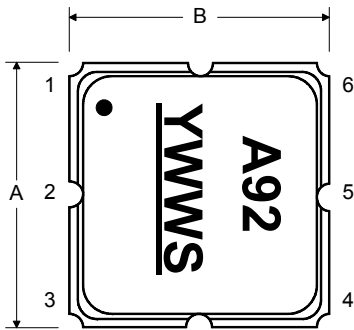

BOTTOM VIEW

