



YENYO

# SF16A01F THRU SF16A06F

Glass Passivated Super Fast Recovery Rectifier

## Features

- ★ Fast switching for high efficiency
- ★ Low forward voltage drop
- ★ High current capability
- ★ Low reverse leakage current
- ★ High surge current capability

## Mechanical Data

- ★ Case: Molded plastic ITO-220AC
- ★ Epoxy: UL 94V-0 rate flame retardant
- ★ Terminals: Solderable per MIL-STD-202 method 208
- ★ Polarity: Color band denotes cathode
- ★ Mounting position: Any
- ★ Weight: 1.73 grams

**Voltage Range 50 to 600 V  
Current 16.0 Ampere**

### ITO-220AC

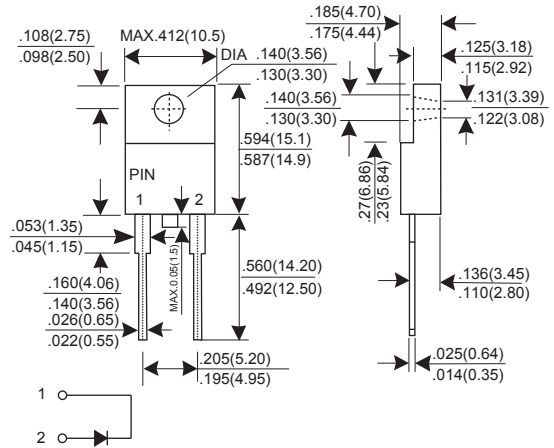

Dimensions in inches and (millimeters)

## MAXIMUM RATINGS AND ELECTRICAL CHARACTERISTICS

Rating at 25°C ambient temperature unless otherwise specified.

Single phase, half wave, 60Hz, resistive or inductive load.

For capacitive load, derate current by 20%.

PARAMTER	SYMBOL	SF 16A01F	SF 16A02F	SF 16A03F	SF 16A04F	SF 16A05F	SF 16A06F	UNIT
Maximum Recurrent Peak Reverse Voltage	VRRM	50	100	200	300	400	600	V
Maximum RMS Voltage	VRMS	35	70	140	210	280	420	V
Maximum DC Blocking Voltage	VDC	50	100	200	300	400	600	V
Maximum Average Forward Rectified Current Tc=100°C	IF(AV)	16.0						A
Peak Forward Surge Current, 8.3ms single Half sine-wave superimposed on rated load (JEDEC method)	IFSM	250						A
Maximum Instantaneous Forward Voltage @ 16.0 A	VF	0.975			1.3		1.7	V
Maximum DC Reverse Current @Tj=25°C At Rated DC Blocking Voltage @Tj=125°C	IR	10.0						uA
		250						uA
Maximum Reverse Recovery Time (Note 1)	Trr	35						nS
Typical junction Capacitance (Note 2)	CJ	130						pF
Typical Thermal Resistance (Note 3)	RθJC	1.7						°CW
Operating Junction and Storage Temperature Range	TJ, TSTG	-55 to +150						°C

NOTES : (1) Reverse recovery test conditions IF = 0.5A, IR = 1.0A, Irr = 0.25A.  
(2) Measured at 1.0 MHz and applied reverse voltage of 4.0 Volts DC.  
(3) Thermal Resistance junction to case.

# RATINGS AND CHARACTERISTIC CURVES SF16A01F THRU SF16A06F

FIG.1 - FORWARD CURRENT DERATING CURVE

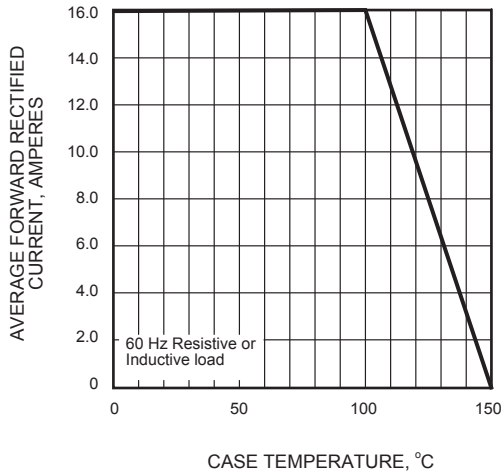

FIG.2 - MAXIMUM NON-REPETITIVE PEAK FORWARD SURGE CURRENT

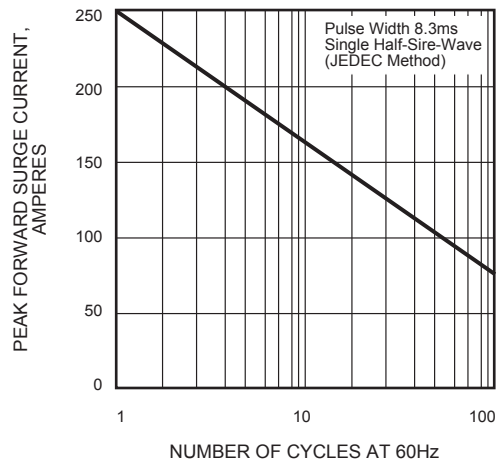

FIG.3 - TYPICAL INSTANTANEOUS FORWARD CHARACTERISTICS

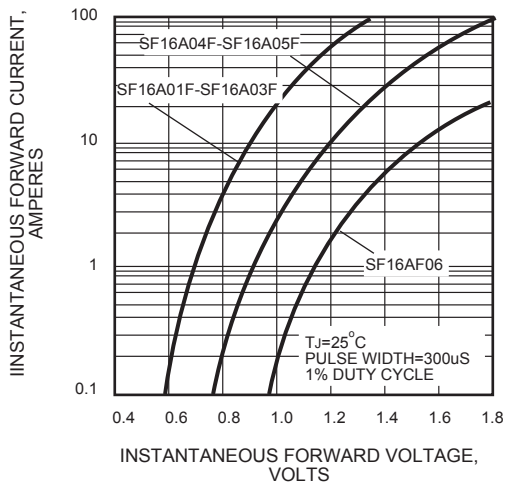

FIG.4 - TYPICAL REVERSE CHARACTERISTICS

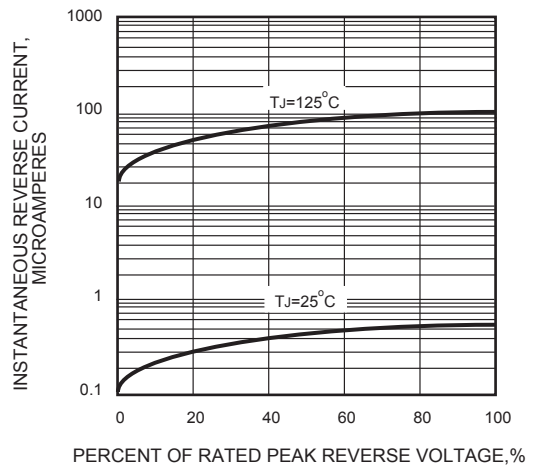

FIG.5 - TYPICAL JUNCTION CAPACITANCE

