



YENYO

SF201G THRU SF207G

Glass Passivated Super Fast Recovery Rectifier

Features

- ★ Fast switching for high efficiency
- ★ Low forward voltage drop
- ★ High current capability
- ★ Low reverse leakage current
- ★ High surge current capability

Mechanical Data

- ★ Case: Molded plastic DO-15
- ★ Epoxy: UL 94V-0 rate flame retardant
- ★ Terminals: Solderable per MIL-STD-202 method 208
- ★ Polarity: Color band denotes cathode
- ★ Mounting position: Any
- ★ Weight: 0.4 gram

**Voltage Range 50 to 800 V
Current 2.0 Ampere**

DO-15

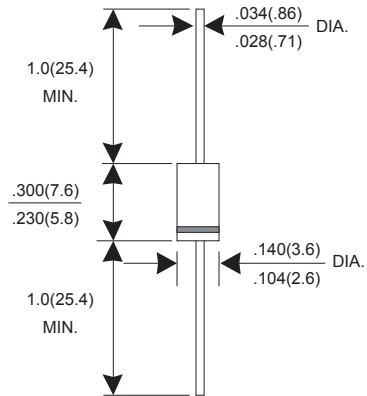

Dimensions in inches and (millimeters)

MAXIMUM RATINGS AND ELECTRICAL CHARACTERISTICS

Rating at 25°C ambient temperature unless otherwise specified.

Single phase, half wave, 60Hz, resistive or inductive load.

For capacitive load, derate current by 20%.

PARAMTER	SYMBOL	SF 201G	SF 202G	SF 203G	SF 204G	SF 205G	SF 206G	SF 207G	UNIT
Maximum Recurrent Peak Reverse Voltage	VRRM	50	100	200	300	400	600	800	V
Maximum RMS Voltage	VRMS	35	70	140	210	280	420	560	V
Maximum DC Blocking Voltage	VDC	50	100	200	300	400	600	800	V
Maximum Average Forward Rectified Current $T_L=55^\circ\text{C}$	IF(AV)	2.0							A
Peak Forward Surge Current, 8.3ms single Half sine-wave superimposed on rated load (JEDEC method)	IFSM	60							A
Maximum Instantaneous Forward Voltage @ 2.0 A	VF	0.95		1.25		1.7		V	
Maximum DC Reverse Current @ $T_J=25^\circ\text{C}$ At Rated DC Blocking Voltage @ $T_J=125^\circ\text{C}$	IR	5.0				100			uA uA
Maximum Reverse Recovery Time (Note 1)	Trr	35							nS
Typical junction Capacitance (Note 2)	CJ	40			20			pF	
Typical Thermal Resistance (Note 3)	RθJA	40							°C/W
Operating Junction and Storage Temperature Range	TJ, TSTG	-55 to +150							°C

NOTES : (1) Reverse recovery test conditions $I_F = 0.5\text{A}$, $I_R = 1.0\text{A}$, $I_{rr} = 0.25\text{A}$.
 (2) Measured at 1.0 MHz and applied reverse voltage of 4.0 Volts DC.
 (3) Thermal Resistance junction to lead.

RATINGS AND CHARACTERISTIC CURVES SF201G THRU SF207G

FIG.1 - FORWARD CURRENT DERATING CURVE

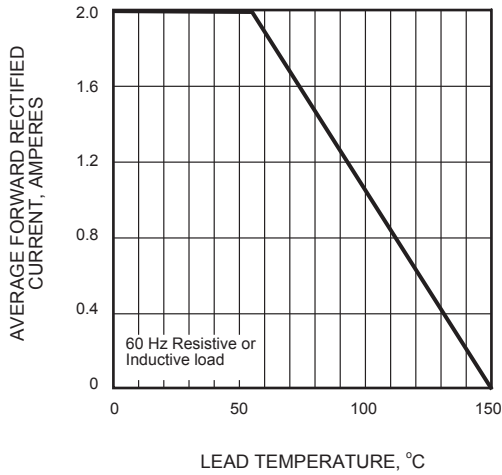

FIG.2 - MAXIMUM NON-REPETITIVE PEAK FORWARD SURGE CURRENT

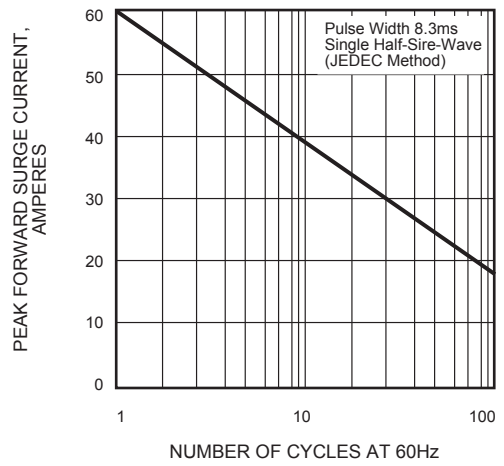

FIG.3 - TYPICAL INSTANTANEOUS FORWARD CHARACTERISTICS

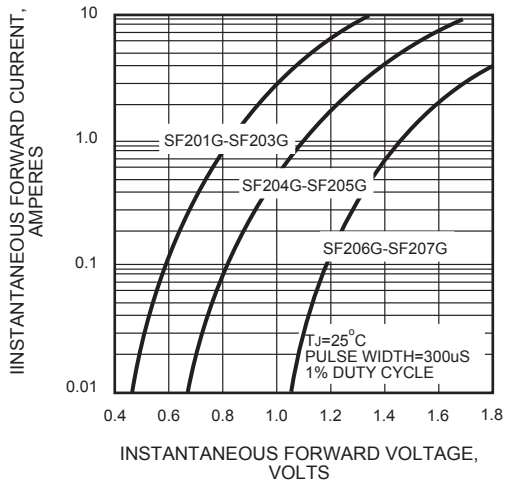

FIG.4 - TYPICAL REVERSE CHARACTERISTICS

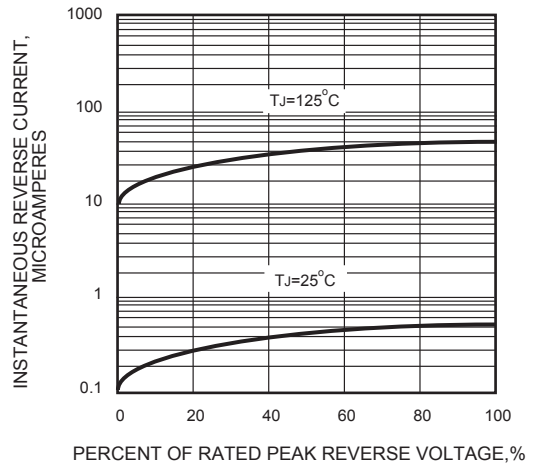

FIG.5 - TYPICAL JUNCTION CAPACITANCE

