

- *Designed for SDARS Receiver IF Application*
- *Low Insertion Loss*
- *3.0 X 3.0 X 1.0 mm Surface-mount Case*
- *Differential Input and Output*
- *Complies with Directive 2002/95/EC (RoHS)*
- *Moisture Sensitivity Level: 1*
- *AEC-Q200 Qualified*

**Absolute Maximum Ratings**

Rating	Value	Units
Maximum Incident Power in Passband	+10	dBm
DC Voltage on any Non-ground Terminal	30	VDC
Operating Temperature Range	-40 to +105	°C
Storage Temperature Range in Tape and Reel	-40 to +85	°C
Suitable for Lead-free Soldering - Maximum Soldering Profile	260 °C for 30 s	

**SF2024E-1**

**467.751 MHz  
SAW Filter**

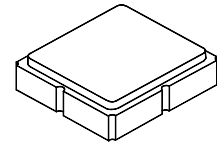

**SM3030-8**

**Electrical Characteristics**

Characteristic	Sym	Notes	Min	Typ	Max	Units
Center Frequency	$f_c$		467.704	467.751	467.798	MHz
Insertion Loss	IL			12	14.5	dB
Amplitude Ripple						dB <sub>p-p</sub>
fc-6.250 to fc-4.3925 MHz				1.0	2.0	
fc-4.3925 to fc-2.535 MHz				0.6	2.0	
fc-2.5350 to fc-0.025 MHz				1.7	2.2	
fc+0.025 to fc+2.535 MHz				1.2	2.0	
fc+2.5350 to fc+4.3925 MHz				0.7	2.0	
fc+4.3925 to fc+6.250 MHz				0.8	2.2	
2.0 dB Bandwidth, Centered at fc				13.0		MHz
3.0 dB Bandwidth				13.9		
Low Side Attenuation between 455.751 to 457.251 MHz (fc-10.5 MHz)			21	32		dB
Low Side Attenuation Below 455.751 MHz			28	33		
High Side Attenuation between 476.751 to 479.751 MHz (fc+9.0 MHz)			15	27		
High Side Attenuation Above 479.751 MHz			25	38		
Temperature Coefficient of Frequency					-18	ppm/K
Group Delay Ripple:						ns <sub>p-p</sub>
fc-6.250 to fc-4.3925 MHz				43	150	
fc-4.3925 to fc-2.535 MHz				27	100	
fc-2.5350 to fc-0.025 MHz				20	120	
fc+0.025 to fc+2.535 MHz				27	120	
fc+2.5350 to fc+4.3925 MHz				27	100	
fc+4.3925 to fc+6.250 MHz				32	300	
Case Style			SM3030-8 3.0 x 3.0 mm Nominal Footprint			
Lid Symbolization (YY=year, WW=week, S=shift)			633 ,YWWS			



**CAUTION: Electrostatic Sensitive Device. Observe precautions for handling.**

**NOTES:**

1. The design, manufacturing process, and specifications of this device are subject to change.
2. US or International patents may apply.
3. RoHS compliant from the first date of manufacture.

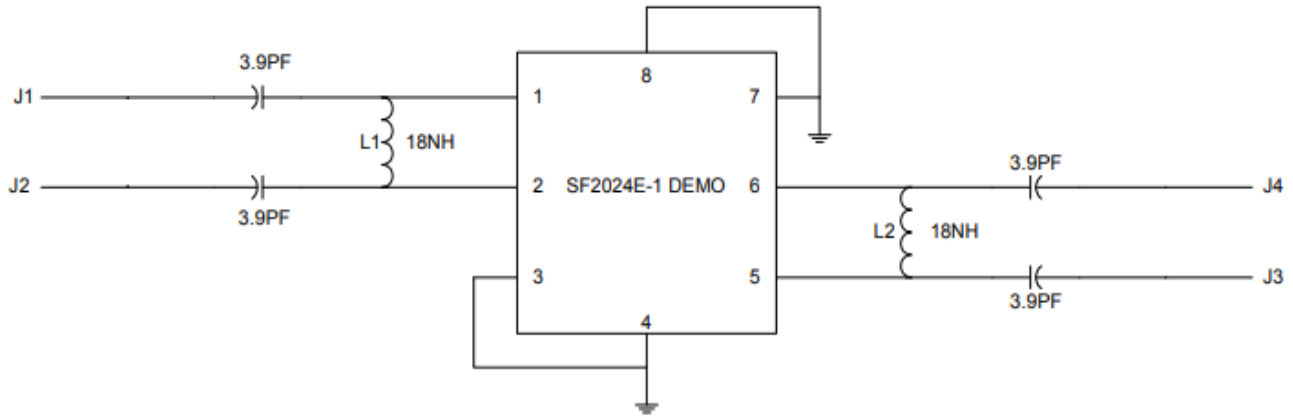

INDUCTOR, 0402 COIL CRAFT  
CAP, 0201

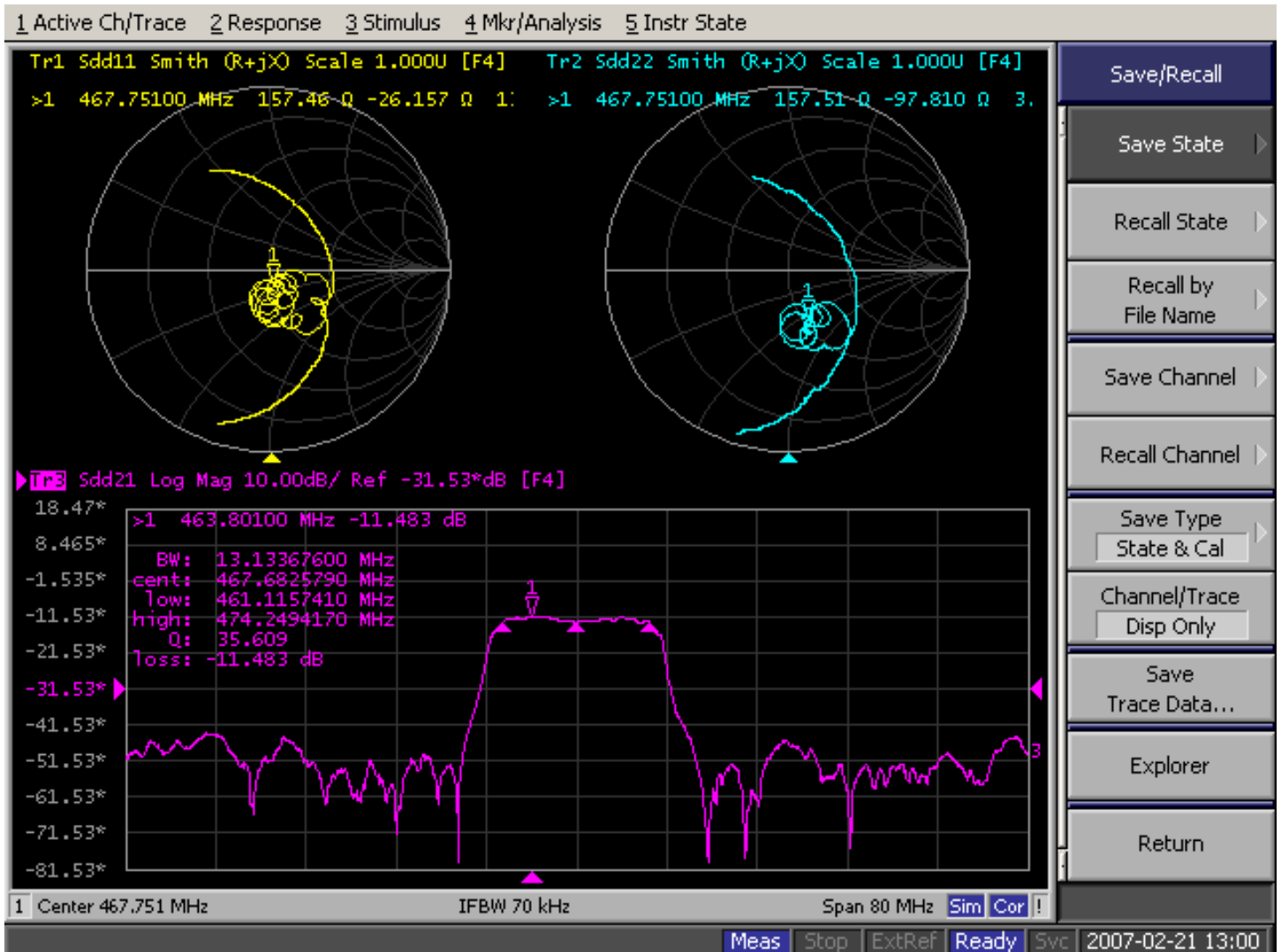

## 8-Terminal Ceramic Surface-Mount Case 3.0 X 3.0 mm Nominal Footprint

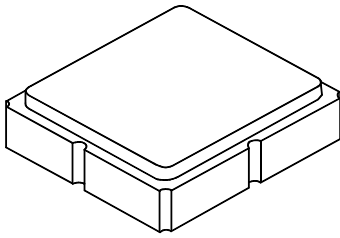

### Case and PCB Footprint Dimensions

Dimension	mm			Inches		
	Min	Nom	Max	Min	Nom	Max
A	2.87	3.0	3.13	0.113	0.118	0.123
B	2.87	3.0	3.13	0.113	0.118	0.123
C	1.14	1.27	1.40	0.045	0.050	0.055
D	0.79	0.92	1.05	0.031	0.036	0.041
E	0.62	0.75	0.88	0.024	0.029	0.034
F	0.47	0.60	0.73	0.018	0.024	0.029
G	0.47	0.60	0.73	0.018	0.024	0.029
H	1.07	1.20	1.33	0.042	0.047	0.052
I		3.19			0.126	
J		0.81			0.032	
K		0.96			0.038	
L		0.81			0.032	
M		1.39			0.055	
N		0.23			0.009	
O		0.38			0.015	

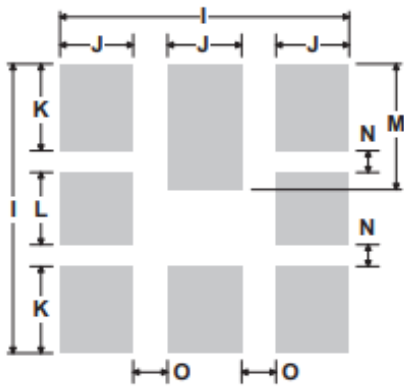

PCB Footprint Top View

### Case Materials

Materials	
Solder Pad Plating	0.3 to 1.0 $\mu\text{m}$ Gold over 1.27 to 8.89 $\mu\text{m}$ Nickel
Lid Plating	2.0 to 3.0 $\mu\text{m}$ Nickel
Body	$\text{Al}_2\text{O}_3$ Ceramic

TOP VIEW

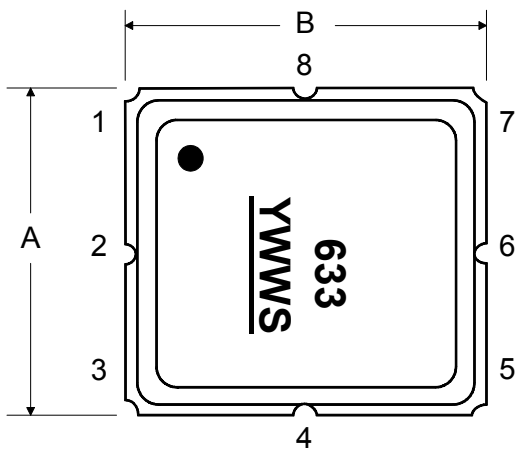

BOTTOM VIEW

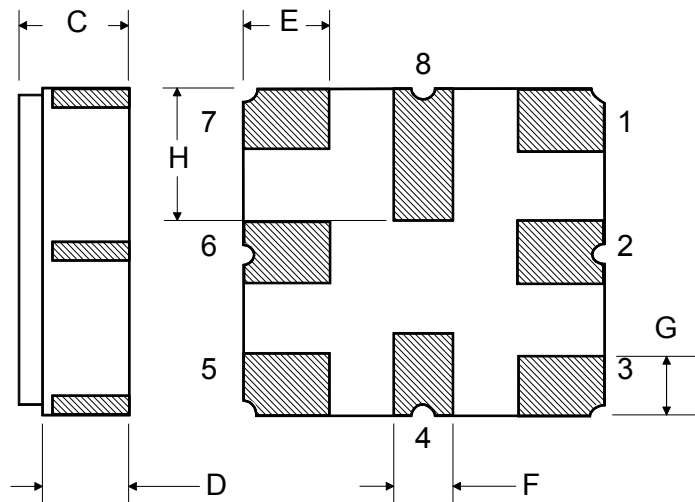

## Tape and Reel Specifications

Tape and Reel Standard per ANSI/EIA-481

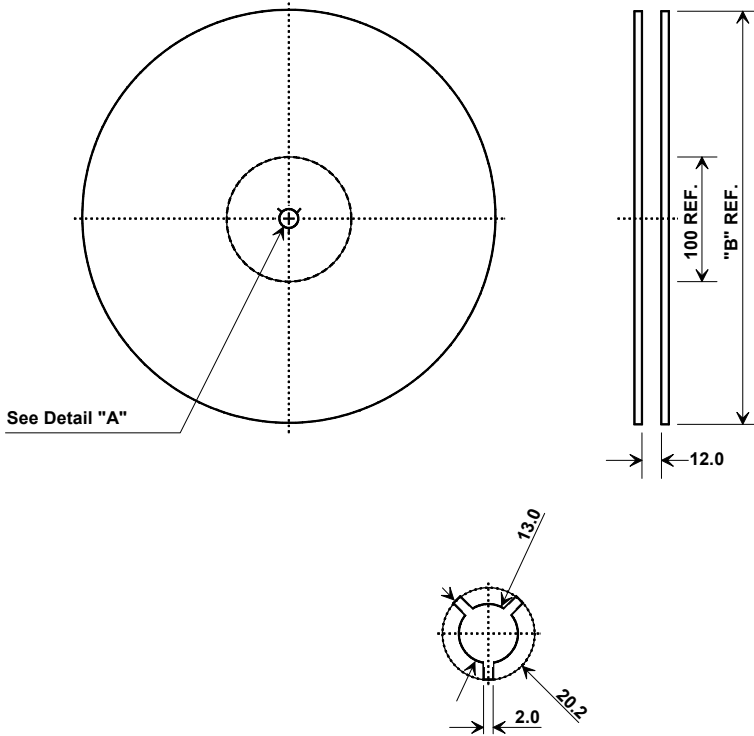

"B"		Quantity Per Reel
Inches	millimeters	
7	178	500
13	330	3000

Carrier Tape Dimensions	
Ao	3.35 mm
Bo	3.35 mm
Ko	1.4 mm
Pitch	8.0 mm
W	12.0 mm

### COMPONENT ORIENTATION

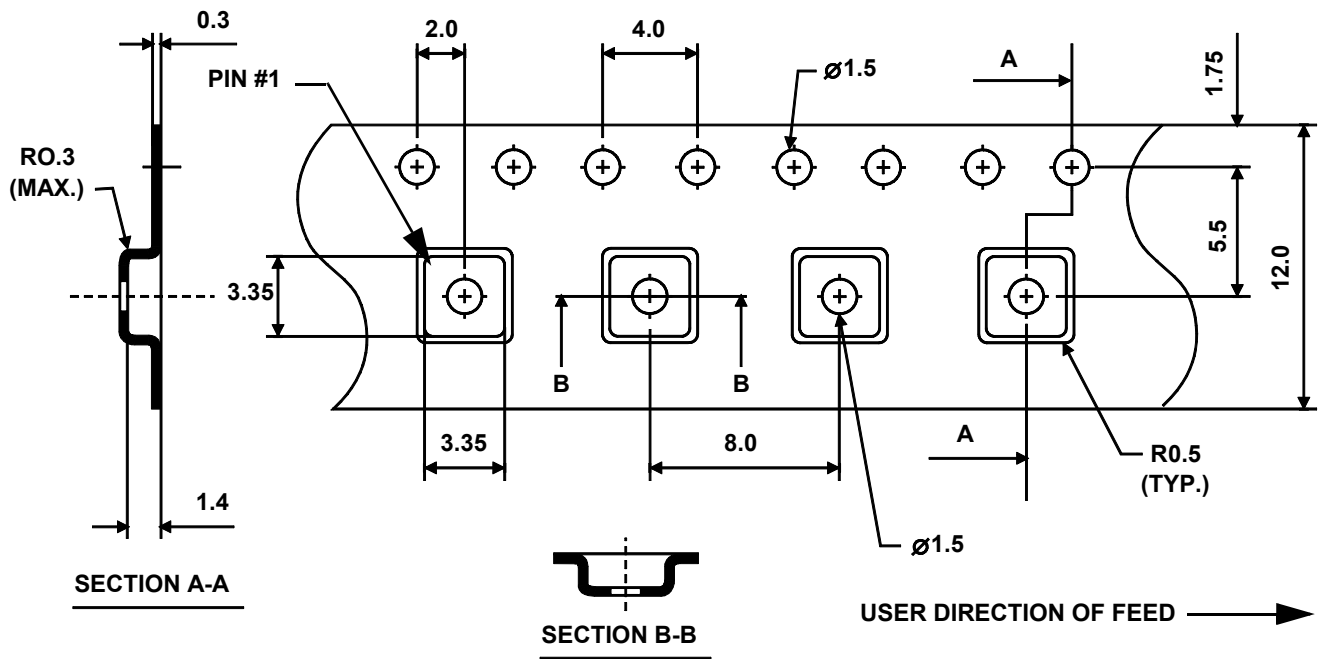

## Recommended Reflow Profile

1. Preheating shall be fixed at 150~180°C for 60~90 seconds.
2. Ascending time to preheating temperature 150°C shall be 30 seconds min.
3. Heating shall be fixed at 220°C for 50~80 seconds and at 260°C+0/-5°C peak (10 seconds).
4. Time: 5 times maximum.

