

# Preliminary



- Designed for SDARS Receiver IF Application
- Low Insertion Loss
- 3.0 X 3.0 X 1.0 mm Surface-mount Case
- Differential Input and Output
- Complies with Directive 2002/95/EC (RoHS)



**SF2024E-2**

**467.751 MHz  
SAW Filter**

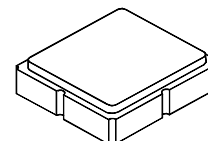

**SM3030-8**

## Absolute Maximum Ratings

Rating	Value	Units
Maximum Incident Power in Passband	+10	dBm
Maximum DC Voltage on any Non-ground Terminals	30	VDC
Operating Temperature Range	-40 to +85	°C
Storage Temperature Range in Tape and Reel	-40 to +85	°C
Suitable for Lead-free Soldering - Maximum Soldering Profile	260 °C for 30 s	

## Electrical Characteristics

Characteristic	Sym	Notes	Min	Typ	Max	Units
Center Frequency	$f_c$	1	467.704	467.751	467.798	MHz
Insertion Loss	IL			12	14.5	dB
Amplitude Ripple:						
fc-6.250 to fc-4.3925 MHz		1, 2		0.74	2.0	dB <sub>p-p</sub>
fc-4.3925 to fc-2.535 MHz				0.4	2.0	
fc-2.5350 to fc-0.025 MHz				0.4	2.0	
fc+0.025 to fc+2.535 MHz				0.5	2.0	
fc+2.5350 to fc+4.3925 MHz				0.3	2.0	
fc+4.3925 to fc+6.250 MHz				0.9	2.0	
2.0 dB Bandwidth Centered at fc				13.0		MHz
3.0 dB Bandwidth				13.9		
Low Side Attenuation Between 455.751 to 457.251 MHz (fc-10.5 MHz)			32	37		dB
Low Side Attenuation Below 455.751 MHz			28	33		
High Side Attenuation Between 476.751 to 479.751 MHz (fc+9.0 MHz)			20	27		
High Side Attenuation Above 479.751 MHz			32	38		
Temperature Coefficient of frequency					-18	ppm/K
Group Delay Ripple:						
fc-6.250 to fc-4.3925 MHz		1, 2, 3		43	100	ns <sub>p-p</sub>
fc-4.3925 to fc-2.535 MHz				27	100	
fc-2.5350 to fc-0.025 MHz				20	120	
fc+0.025 to fc+2.535 MHz				27	120	
fc+2.5350 to fc+4.3925 MHz				27	100	
fc+4.3925 to fc+6.250 MHz				32	100	
Case Style		6	SM3030-8 3.0 x 3.0 mm Nominal Footprint			
Lid Symbolization (YY=year, WW=week, S=shift) See note 4			TBD YWWS			



**CAUTION: Electrostatic Sensitive Device. Observe precautions for handling.**

### Notes:

1. Unless noted otherwise, all specifications apply over the operating temperature range with filter soldered to the specified demonstration board with impedance matching to 50 Ω and measured with 50 Ω network analyzer.
2. Unless noted otherwise, all frequency specifications are referenced to the nominal center frequency,  $f_c$ .
3. Rejection is measured as attenuation below the minimum IL point in the passband. Rejection in final user application is dependent on PCB layout and external impedance matching design. See Application Note No. 42 for details.
4. The design, manufacturing process, and specifications of this filter are subject to change.
5. Tape and Reel Standard Per ANSI / EIA 481.
6. US and international patents may apply.
7. RFM, stylized RFM logo, and RF Monolithics, Inc., are registered trademarks of RF Monolithics, Inc.

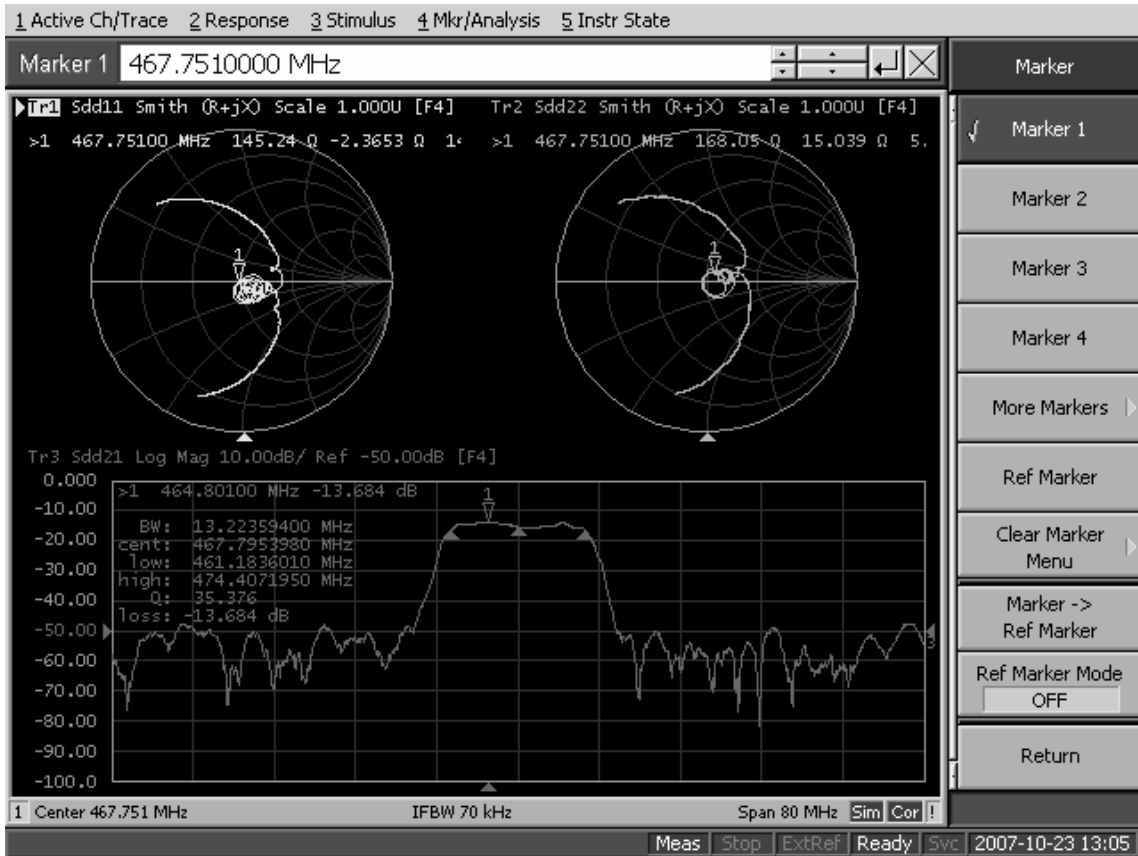

	Connection	Terminals
Port 1	Balanced Input	1, 3
Port 2	Balanced Output	5, 7
	Ground	All Others

Dot Indicates Pin 1

### Tuning Network, Bottom View

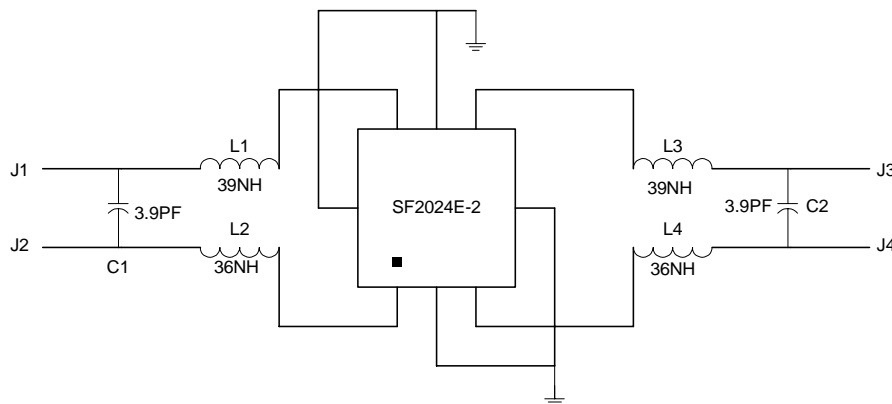

## 8-Terminal Ceramic Surface-Mount Case 3.0 X 3.0 mm Nominal Footprint

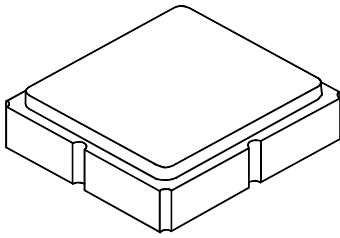

### Case and PCB Footprint Dimensions

Dimension	mm			Inches		
	Min	Nom	Max	Min	Nom	Max
A	2.87	3.0	3.13	0.113	0.118	0.123
B	2.87	3.0	3.13	0.113	0.118	0.123
C	1.14	1.27	1.40	0.045	0.050	0.055
D	0.79	0.92	1.05	0.031	0.036	0.041
E	0.62	0.75	0.88	0.024	0.029	0.034
F	0.47	0.60	0.73	0.018	0.024	0.029
G	0.47	0.60	0.73	0.018	0.024	0.029
H	1.07	1.20	1.33	0.042	0.047	0.052
I		3.19			0.126	
J		0.81			0.032	
K		0.96			0.038	
L		0.81			0.032	
M		1.39			0.055	
N		0.23			0.009	
O		0.38			0.015	

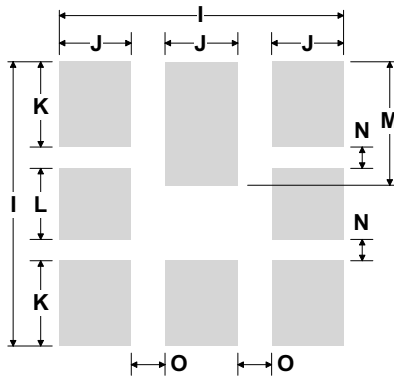

PCB Footprint Top View

### Case Materials

Materials	
Solder Pad Plating	0.3 to 1.0 $\mu\text{m}$ Gold over 1.27 to 8.89 $\mu\text{m}$ Nickel
Lid Plating	2.0 to 3.0 $\mu\text{m}$ Nickel
Body	$\text{Al}_2\text{O}_3$ Ceramic
	Pb Free

TOP VIEW

BOTTOM VIEW

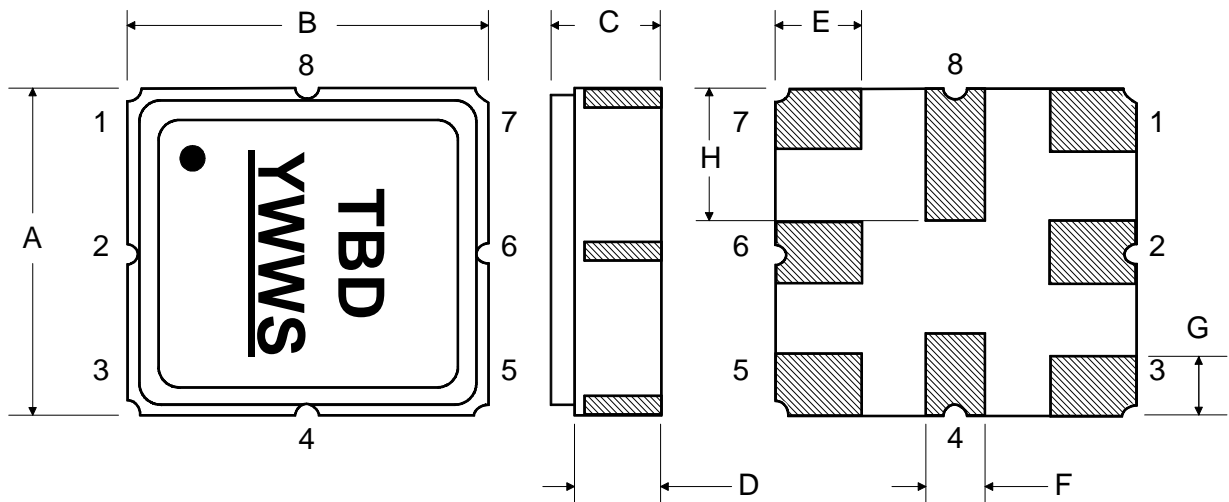

## Tape and Reel Specifications

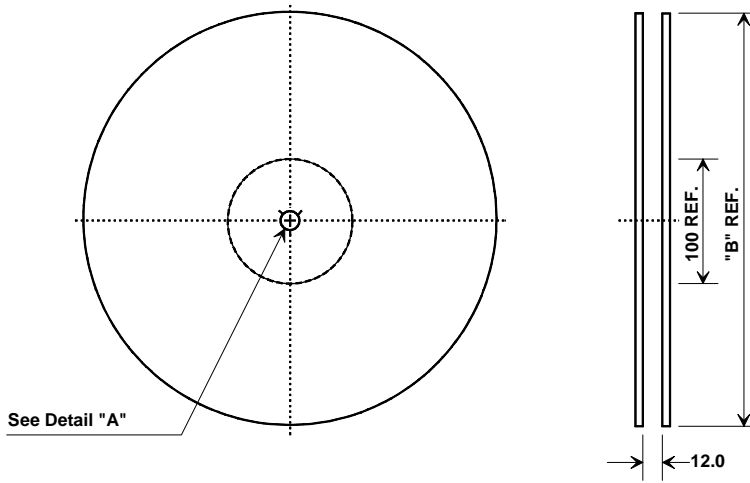

"B"		Quantity Per Reel
Inches	millimeters	
7	178	500
13	330	3000

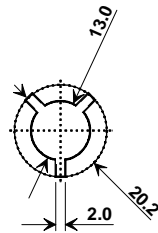

Carrier Tape Dimensions	
Ao	3.35 mm
Bo	3.35 mm
Ko	1.4 mm
Pitch	8.0 mm
W	12.0 mm

## COMPONENT ORIENTATION

