

- **Precision SAW Filter**
- **Excellent Size-to-performance Ratio**
- **Hermetic 13.3 x 6.5 mm Surface-mount Case**

Absolute Maximum Ratings

Rating	Value	Units
Input Power Level	+10	dBm
Storage Temperature Range in Tape and Reel	-40 to +85	°C
Operating Temperature Range	-40 to +85	°C
Suitable for Lead-free Soldering - Maximum Soldering Profile	260 °C for 30 s	

SF2140A

**140.0 MHz
SAW Filter**

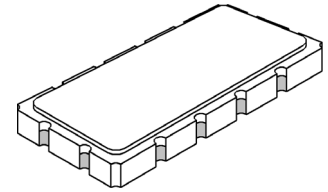

SMP-53

Electrical Characteristics

Characteristic	Sym	Notes	Min	Typ	Max	Units
Nominal Center Frequency	f_c	1		140.0		MHz
Minimum Insertion loss	IL_{MIN}			9.2	10.5	dB
1 dB Bandwidth			18.4	20.8		MHz
3 dB Bandwidth			20.0	21.8		MHz
35 dB Bandwidth				25.5	26.4	MHz
Amplitude Ripple, 130.9 to 149.1 MHz				0.75	1.0	dB _{P-P}
Group Delay Ripple, 130.9 to 149.1 MHz				115	150	ns _{P-P}
Group Delay				1.05		µs
Input VSWR, 0.9 to 149.1 MHz				2.0:1	2.5:1	dB
Output VSWR, 130.9 to 149.1 MHz				1.7:1	2.3:1	dB
Temp Coefficient				-93		ppm/°C
Attenuation Referenced to IL_{MIN} :						
10 to 90 MHz			35	62		dB
190 to 120 MHz			40	54		dB
120.0 to 126.8 MHz			35	42		dB
154.7 to 160.0 MHz			35	45		dB
160 to 190 MHz			40	43		dB
190 to 800 MHz			35	62		dB
Case Style	SMP-53 13.3 X 6.5 mm Nominal Footprint					
Lid Symbolization, YY=year, WW=week, S = shift	RFM SF2140A YYWWS##					



CAUTION: Electrostatic Sensitive Device. Observe precautions for handling.

NOTES:

1. Unless noted otherwise, all specifications apply over the operating temperature range with filter soldered to the specified demonstration board with impedance matching to 50 Ω and measured with 50 Ω network analyzer.
2. Unless noted otherwise, all frequency specifications are referenced to the nominal center frequency, f_c .
3. Rejection is measured as attenuation below the minimum IL point in the passband. Rejection in final user application is dependent on PCB layout and external impedance matching design. See Application Note No. 42 for details.
4. "LRIP" or "L" after the part number indicates "low rate initial production" and "ENG" or "E" indicates "engineering prototypes."
5. The design, manufacturing process, and specifications of this filter are subject to change.
6. Either Port 1 or Port 2 may be used for either input or output in the design. However, impedances and impedance matching may vary between Port 1 and Port 2, so that the filter must always be installed in one direction per the circuit design.
7. US and international patents may apply.
8. Murata, stylized Murata logo, and Murata N.A., Inc. are registered trademarks of Murata Manufacturing Co., Ltd.

Frequency Characteristics:

1. S21 Response

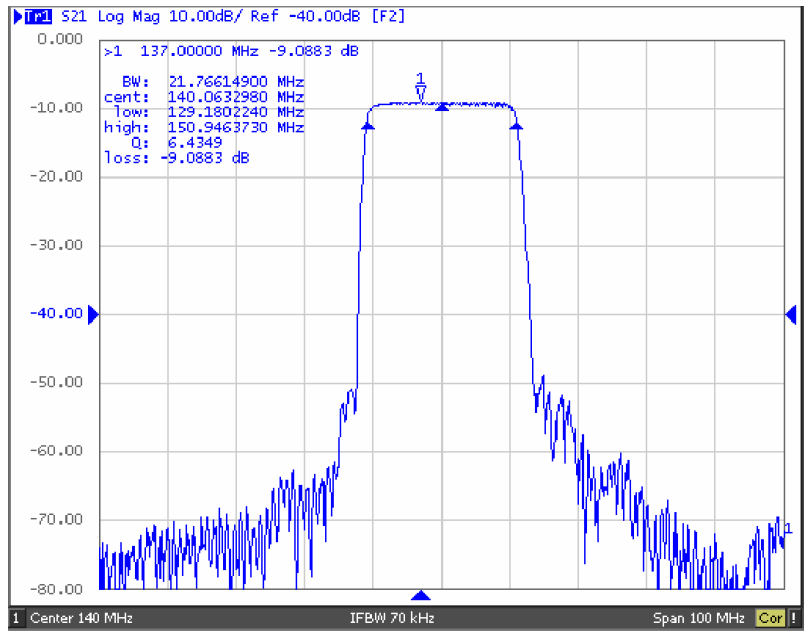

S21 Response Horizontal: 10 MHz/Div Vertical: 10 dB/Div

2. Passband Amplitude Ripple

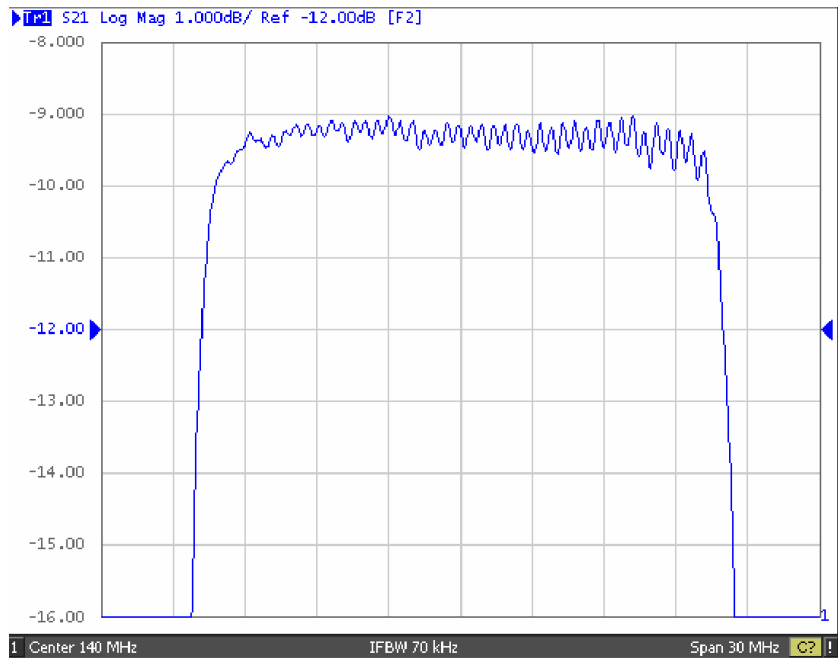

Inband ripple Horizontal: 3 MHz/Div Vertical: 1 dB/Div

3. Group Delay Ripple

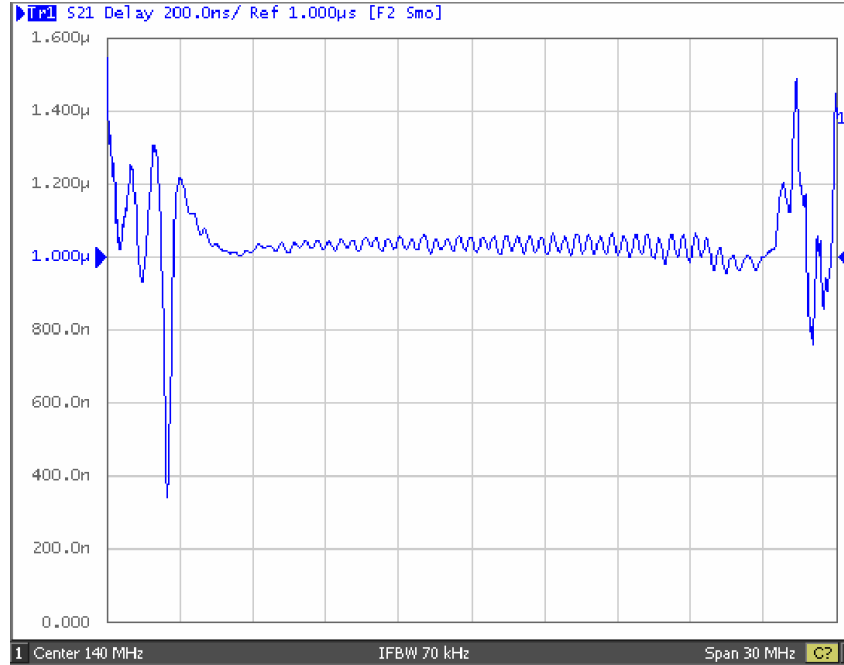

Horizontal: 3 MHz/Div Vertical: 200 nS/Div

Measurement Circuits:

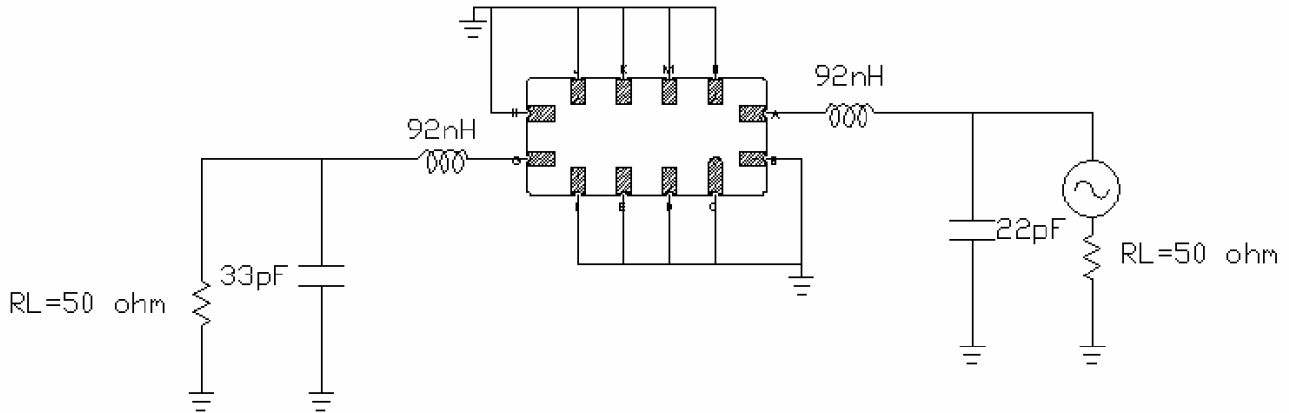

PCB Footprint:



Tape and Reel Specifications

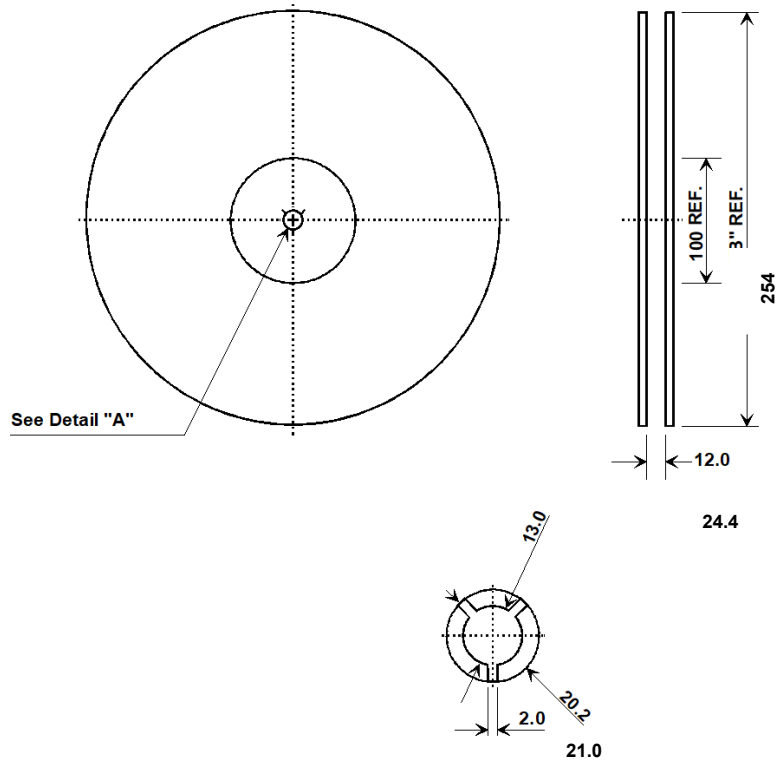

Quantity Per Reel	
100	Min
1000	Max

COMPONENT ORIENTATION and DIMENSIONS

Carrier Tape Dimensions	
Ao	7.0 mm
Bo	13.8 mm
Ko	2.0 mm
Pitch	12.0 mm
W	24.0 mm

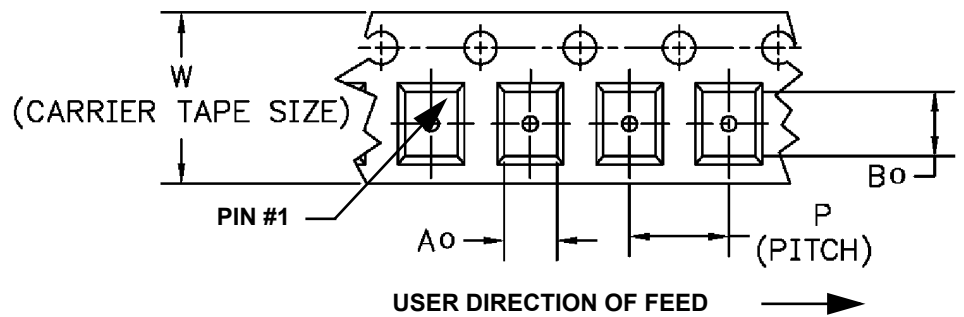
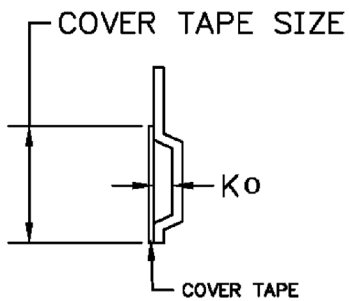

SMP-53 Case

12-Terminal Ceramic Surface-Mount Case 13.3 x 6.5 mm Nominal Footprint

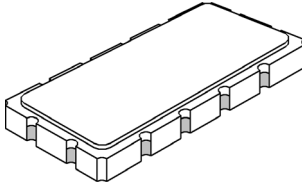

Case Dimensions						
Dimension	mm			Inches		
	Min	Nom	Max	Min	Nom	Max
A	13.08	13.3	13.6	0.515	0.524	0.535
B	6.27	6.5	6.80	0.247	0.256	0.268
C			1.6			
D		1.5				
E		0.80				
H		0.60				
P		2.54				

Electrical Connections	
Connection	Terminals
RF Input	11
RF Input Ground	12
RF Output	5
RF Output Ground	6
Ground	All others

Materials	
Solder Pad Plating	0.3 to 1.0 μm Gold over 1.27 to 8.89 μm Nickel
Lid Plating	2.0 to 3.0 μm Nickel
Body	Al_2O_3 Ceramic
Pb Free	

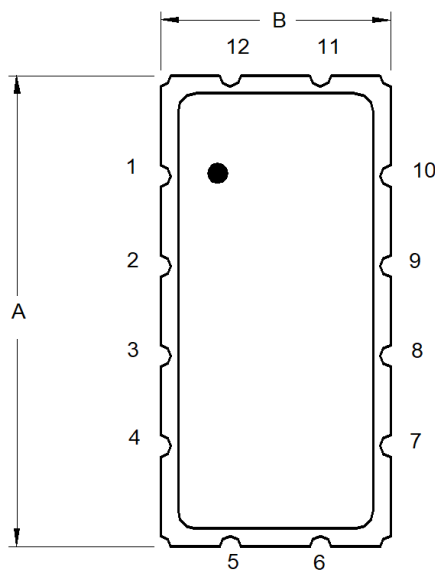

TOP VIEW

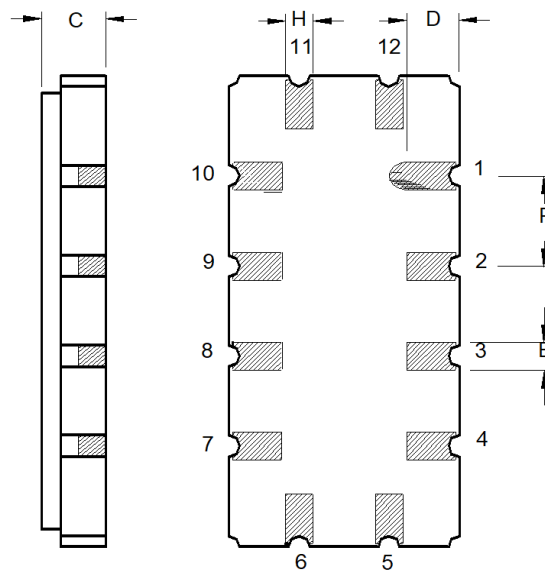

BOTTOM VIEW