

### ● TECHNICAL CHARACTERISTICS

Part Number	3dB Band Width (kHz)	Selectivity	Insertion Loss (dB)	Composition
		$\pm 9\text{kHz}(\text{dB})$ $\pm 9\text{kHz}(\text{dB})\text{min}$		
LTZ455HL	$4.0 \pm 1$	23	7	2 Elements Direct coupling Type
LTZ455JL	$5.5 \pm 1$	18	7	

- Center Frequency( $f_0$ ) is available in range of 450~470kHz
- The nominal frequency tolerance is  $\pm 2\text{kHz}$

### ● RECOMMENDED IFT (7mm Square)

Item	Type	LTZ455HL/JL
		①~② ②~③ ④~⑥
		68T 84T 14T
unload $Q_u$		90
Tuning Capacity		180pF

### ● TEST CIRCUIT

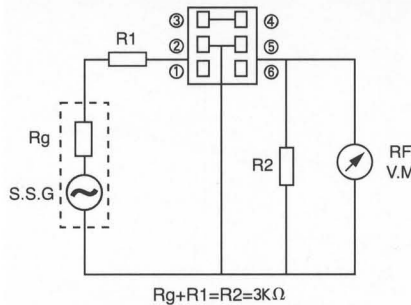

### ● CHARACTERISTICS

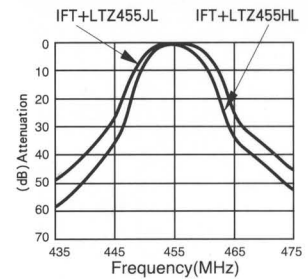

## SFE Series of Ceramic Filter for TV/VCR

## 4.5/5.5/6.0/6.5MHz

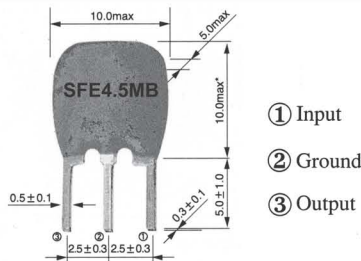

### ● TEST CIRCUIT

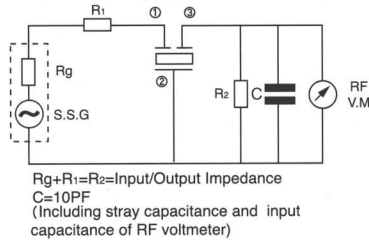

### ● TECHNICAL CHARACTERISTICS

Part Number	3dB Band Width (kHz) min	20dB Band Width (kHz) max	Insertion Loss (dB) max	Spurious Response (dB) min	Input/Output Impedance ( $\Omega$ )
SFE4.5MB	$\pm 60(\pm 105)$	530(420)	6(4)	20(4.5 <sup>+0.8</sup> <sub>-1.0</sub> MHz)	1000
SFE5.5MB	$\pm 75(\pm 120)$	550(470)	6(3)	25(5.5 $\pm 1.0$ MHz)	600
SFE6.0MB	$\pm 80(\pm 130)$	600(500)	6(2.5)	25(6.0 $\pm 1.0$ MHz)	470
SFE6.5MB	$\pm 80(\pm 130)$	630(530)	6(2.5)	25(6.5 $\pm 1.0$ MHz)	470

( ) : Typical Value

### ● CHARACTERISTICS

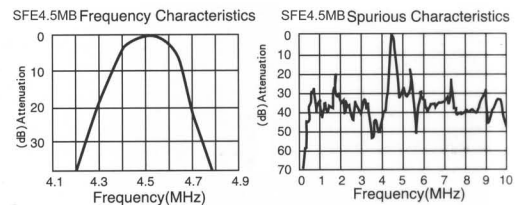

## SFSH Series of Ceramic Filter for TV/VCR

## 4.5/5.5/6.0/6.5MHz

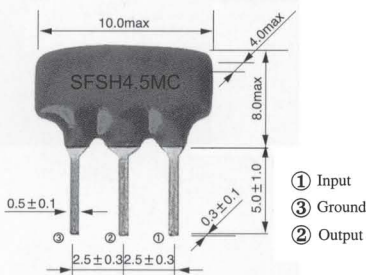

### ● TECHNICAL CHARACTERISTICS

Part Number	3dB Band Width (KHz)	20dB Band Width (KHz)	Insertion Loss (dB) (max)	Spurious Response (dB) (min)	Input / Output Impedance( $\Omega$ )
SFSH4.5MCB	$\pm 60(\pm 110)$	600(470)	6.0	30	1000
SFSH5.5MCB	$\pm 60(\pm 115)$	600(500)	6.0	30	600
SFSH6.0MCB	$\pm 60(\pm 115)$	600(500)	6.0	30	470
SFSH6.5MCB	$\pm 70(\pm 115)$	600(530)	6.0	30	470

( ) : Typical Value

### ● TEST CIRCUIT

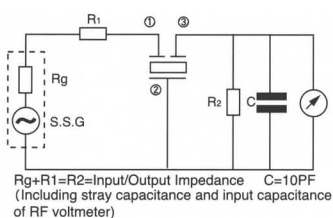

### ● CHARACTERISTICS

