

8A, 600V SUPER-FAST RECOVERY RECTIFIER

GENERAL DESCRIPTION

SFR08S60T2/F2/D is a Super-Fast Recovery Diode, fabricated in advanced silicon planar epitaxial technology. The process parameter and the device structure are fine tuned with optimized performance of forward voltage drop and reverse recovery time.

Accuracy epitaxial dope control, advanced planar junction terminal structure and the platinum doped life control, guarantee the best overall performance, ruggedness and reliability characteristics.

SFR08S60T2/F2 is intended for use in the output rectification stage of SMPS, UPS, DC-DC converters as well as free-wheeling diode in low voltage inverters and chopper motor drivers.

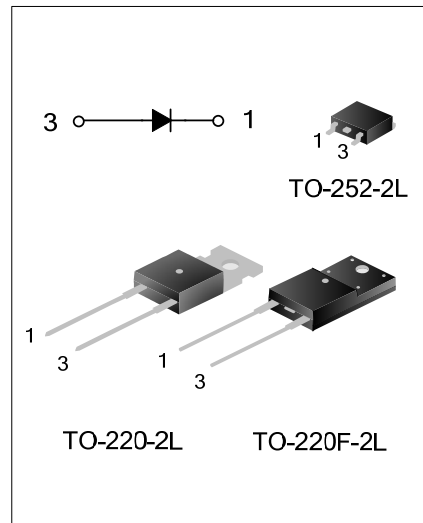

FEATURES

- * Ultrafast 35 Nanosecond Recovery Time
- * Low Forward Voltage Drop
- * Low Leakage Current
- * 150°C Operating Junction Temperature

NOMENCLATURE

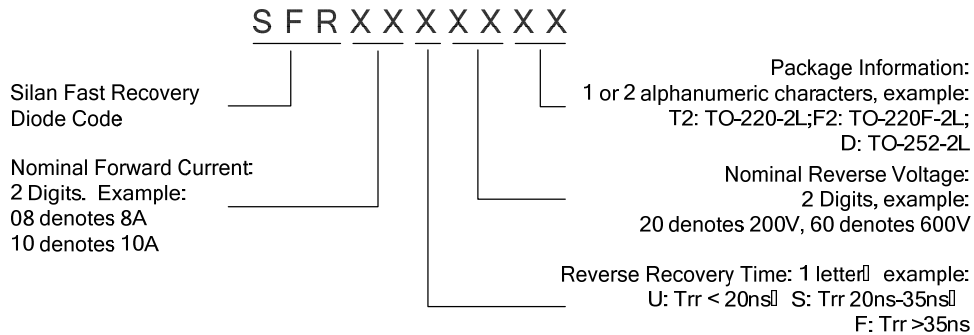

ORDERING INFORMATION

Part No.	Package Type	Marking	Material	Packing
SFR08S60T2	TO-220-2L	SFR08S60T2	Pb free	Tube
SFR08S60F2	TO-220F-2L	SFR08S60F2	Pb free	Tube
SFR08S60D	TO-252-2L	SFR08S60D	Pb free	Tube
SFR08S60DTR	TO-252-2L	SFR08S60D	Pb free	Tape & Reel

ABSOLUTE MAXIMUM RATINGS

characteristics	Symbol	Ratings	Unit
Peak Repetitive Reverse Voltage	V_{RRM}	700	V
Average Rectified Forward Current	$I_{F(AV)}$	8.0	A
Peak Forward Surge Current	I_{FSM}	120	A
Operation Junction Temperature Range	T_J	-50~+150	°C
Storage Temperature Range	T_{stg}	-50~+150	°C

THERMAL CHARACTERISTICS

characteristics	Symbol	Ratings	Unit
Thermal Resistance, Junction-to-Case	$R_{\theta JC}$	2.0	°C/W

ELECTRICAL CHARACTERISTICS

characteristics	Symbol	Min.	Typ.	Max.	Unit
Maximum Forward Voltage $I_F=8.0$ Amps, $T_C=25^\circ\text{C}$	V_F	--	1.95	2.2	V
Maximum Instantaneous Reverse Current Rated dc Voltage, $T_C=25^\circ\text{C}$	I_R	--	--	10.0	μA
Maximum Reverse Recovery Time $I_F=0.5$ Amp, $I_R=1.0$ Amp, $I_{REC}=0.25$ Amp	t_{rr}	--	--	35	ns

TYPICAL CHARACTERISTICS

Figure 1. Forward Characteristic

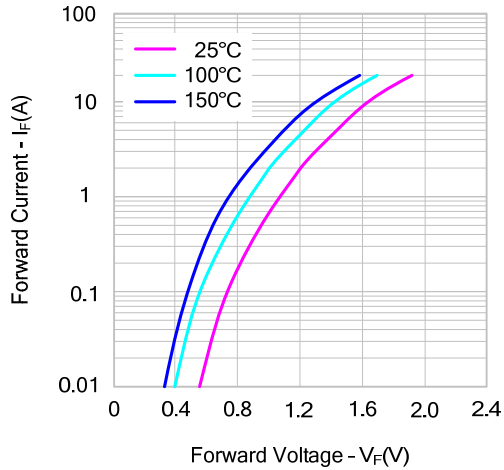

Figure 2. Junction Capacitance Characteristic

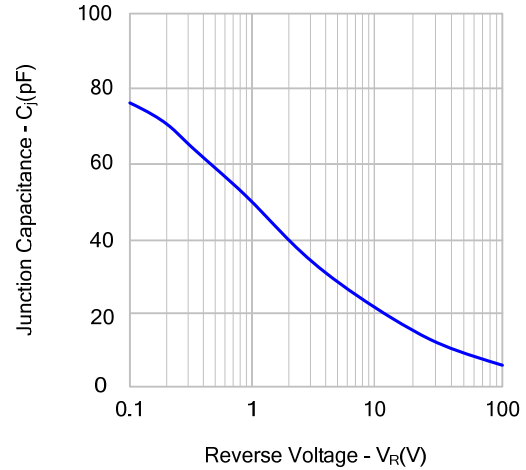

Figure 3. Reverse Characteristic

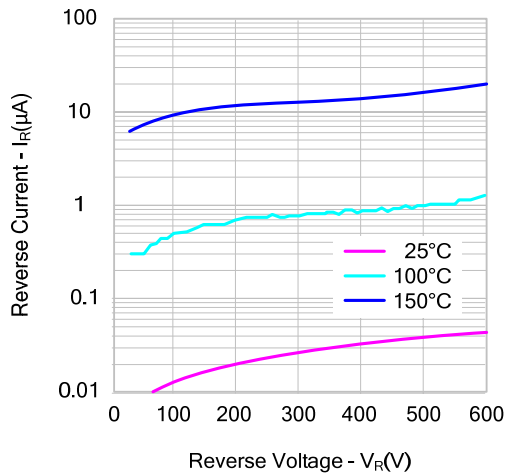
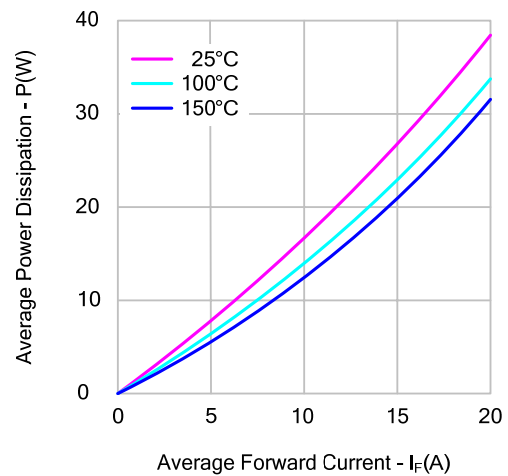
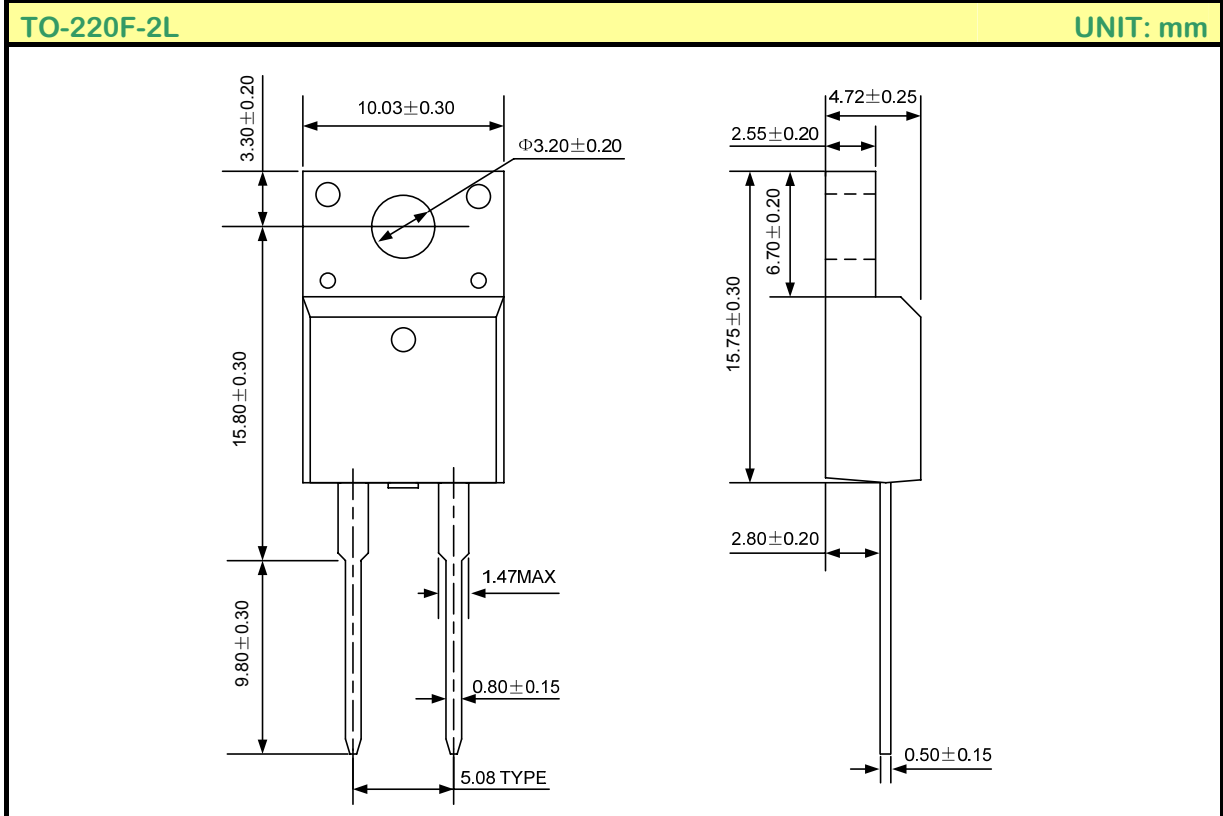
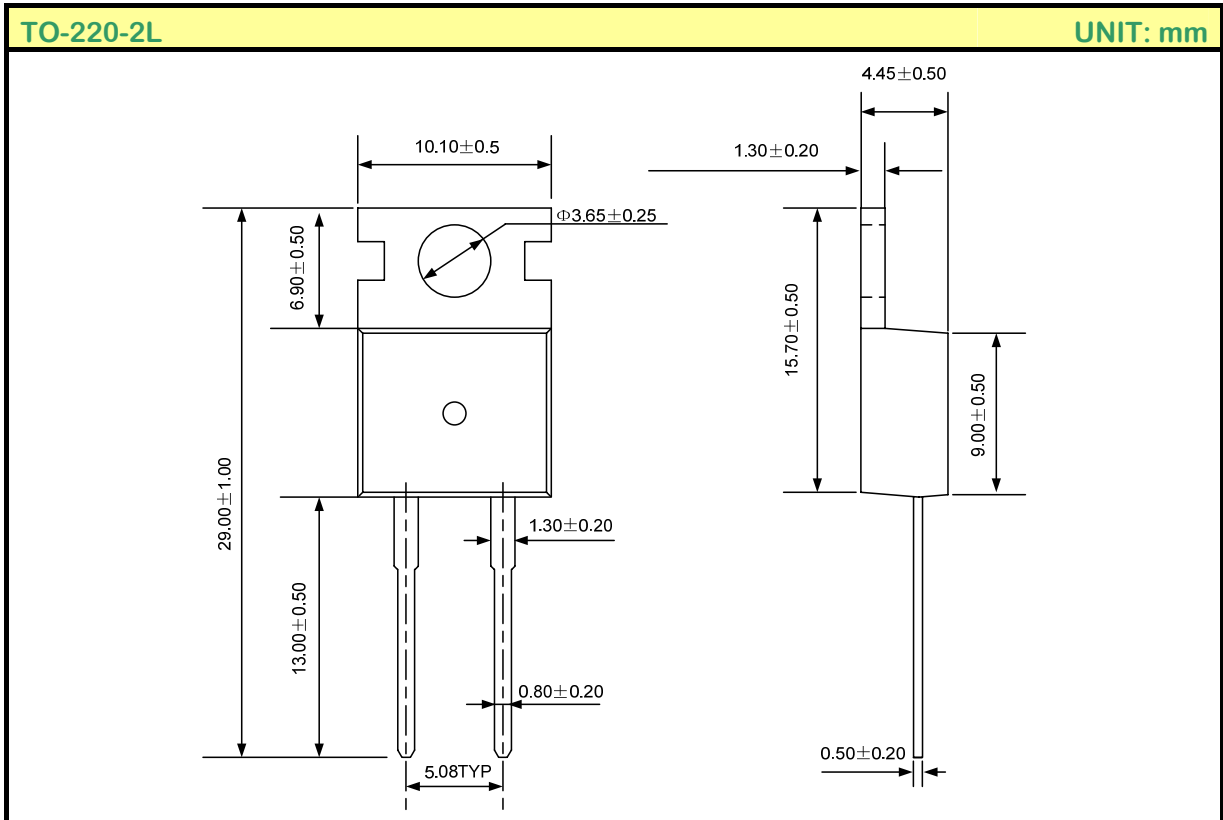

Figure 4. Power Dissipation, Per leg



PACKAGE OUTLINE



PACKAGE OUTLINE(continued)

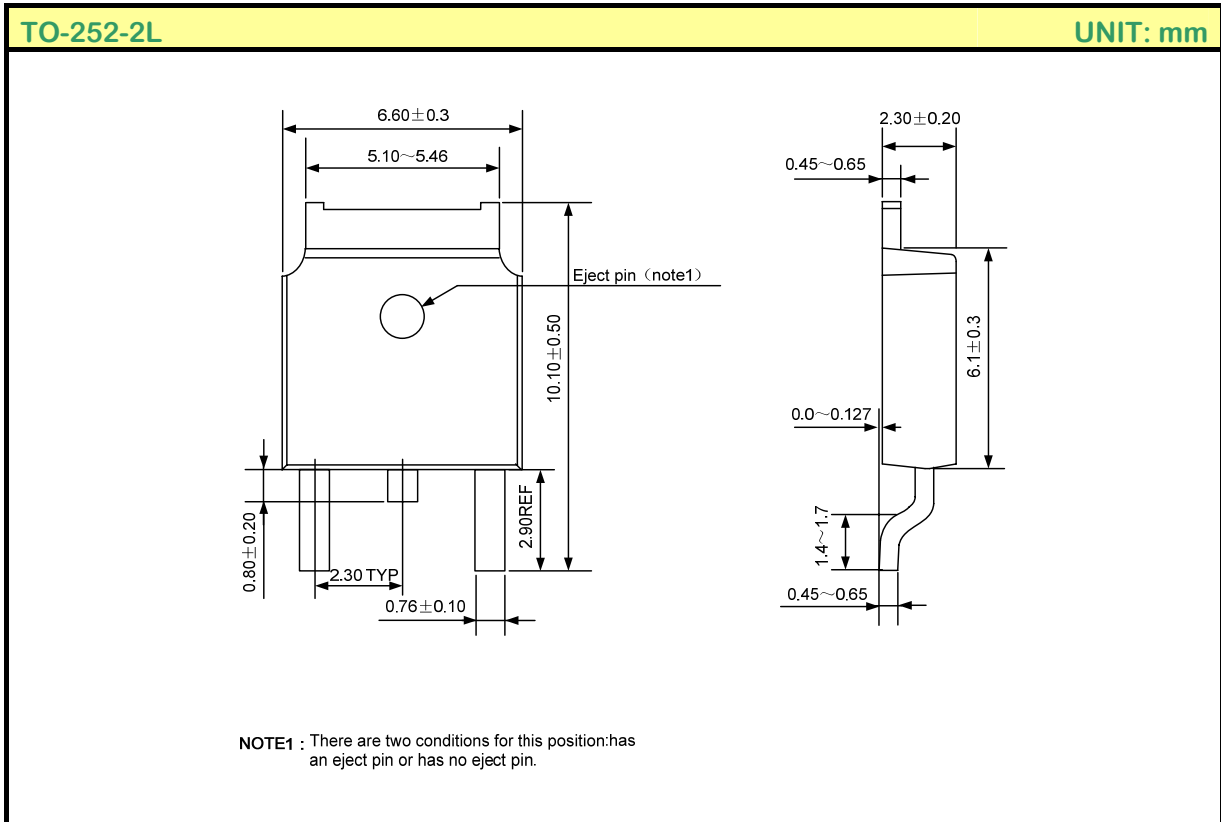

Disclaimer:

- Silan reserves the right to make changes to the information herein for the improvement of the design and performance without further notice! Customers should obtain the latest relevant information before placing orders and should verify that such information is complete and current.
- All semiconductor products malfunction or fail with some probability under special conditions. When using Silan products in system design or complete machine manufacturing, it is the responsibility of the buyer to comply with the safety standards strictly and take essential measures to avoid situations in which a malfunction or failure of such Silan products could cause loss of body injury or damage to property.
- Silan will supply the best possible product for customers!



ATTACHMENT

Revision History

Date	REV	Description	Page
2010.08.30	1.0	Original	
2010.10.20	1.1	Modify the template of Datasheet	
2011.01.17	1.2	Add TO-220F-2L package	
2011.05.30	1.3	Modify the "ABSOLUTE MAXIMUM RATINGS", "ELECTRICAL CHARACTERISTICS"	
2011.06.08	1.4	Add TO-252-2L package	