

# 0.8mm FLEX CIRCUIT / FLAT CABLE / CIC

## SURFLOK™ SFR SERIES

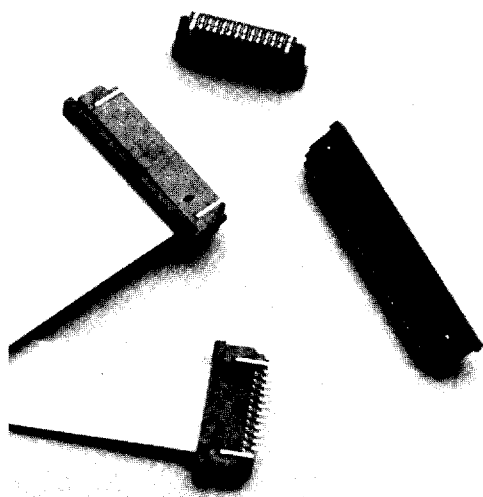

Surflok SFR series features an 0.8mm spacing surface mount, low profile design (2.5mm body height) which accommodates flexible printed circuit, flexible flat cable, conductive ink circuit.

- **Zero insertion force**
  - Conductor locks in with positive “snap”, yet is easily released.
- **Compact**
  - 0.8mm contact spacing and 2.5mm body height for closer packaging densities.
- **SMT**
  - Fine pattern design.
- **Auto Mounting**
  - Packaged in reeled embossed tape for auto mounting.
- **High Reliability**
  - Exclusive GTH™ contact system for good-as-gold performance at significant cost savings.

### ■ DIMENSIONS

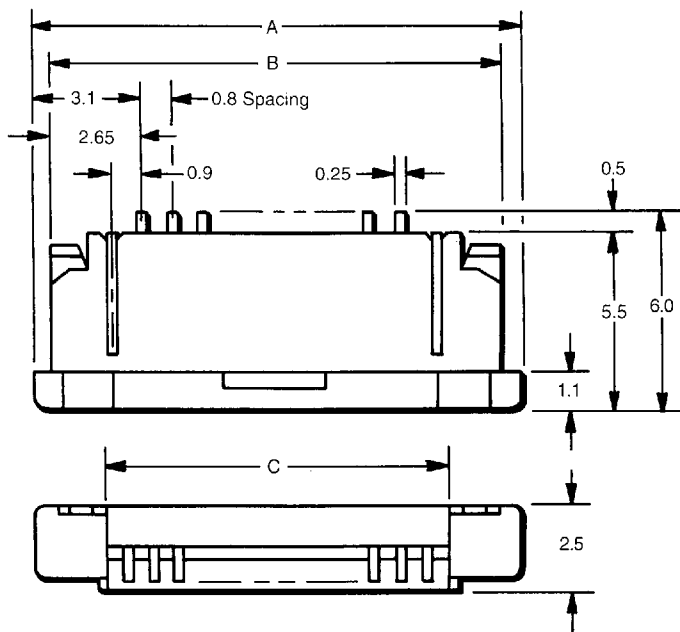

No. of Contacts	Catalog Number	Dimensions		
		A	B	C
4	SFR4R-1/5STE1	8.6	7.7	4.2
6	SFR6R-1/5STE1	10.2	9.3	5.8
8	SFR8R-1/5STE1	11.8	10.9	7.4
10	SFR10R-1/5STE1	13.4	12.5	9.0
12	SFR12R-1/5STE1	15.0	14.1	10.6
14	SFR14R-1/5STE1	16.6	15.7	12.2
16	SFR16R-1/5STE1	18.2	17.3	13.8
18	SFR18R-1/5STE1	19.8	18.9	15.4
20	SFR20R-1/5STE1	21.4	20.5	17.0
22	SFR22R-1/5STE1	23.0	22.1	18.6
24	SFR24R-1/5STE1	24.6	23.7	20.2
26	SFR26R-1/5STE1	26.2	25.3	21.8
28	SFR28R-1/5STE1	27.8	26.9	23.4
30	SFR30R-1/5STE1	29.4	28.5	25.0

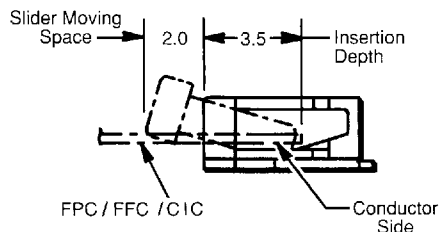

GTH™ is a registered trademark of The Burndy Corp.

**■ PERFORMANCE CHARACTERISTICS**

**Operating Temperature** ..... -55°C to +85°C

**Electrical**

Operating Voltage ..... 100V A.C.  
Current Rating ..... 0.5A Max./contact  
Contact Resistance ..... 30mΩ Max.  
Insulation Resistance ..... 500MΩ Min.  
Dielectric Withstanding Voltage ..... 500V A.C.

**Physical**

Durability ..... Contact Resistance 50mΩ Max.  
after 20 insertions and withdrawals  
Vibration ..... No discontinuity greater than 1 microsecond  
per JIS-C-0040

**Environmental**

Salt Spray ..... Contact Resistance 50mΩ Max.  
per JIS-C-5028  
Moisture Resistance ..... Contact Resistance 50mΩ Max.  
per JIS-C-5023  
Insulation Resistance 100MΩ Min.  
Temperature Cycling ..... Contact Resistance 50mΩ Max.  
per JIS-C-5033

**■ MATERIAL**

Body/Slider ..... Glass-filled Polyphenylene Sulphide (PPS)  
Color: Body ..... Black  
Slider ..... Black (Beige for type 5)

Flammability Rating ..... UL94V-O  
Contact ..... Phosphor Bronze (Tin Alloy plated)

**■ ASSEMBLY PROCEDURES**

- ① Pull up the slider after reflow soldering on the position.
- ② Insert the \*FPC/\*FFC/\*CIC into slot of connector.

- ③ Push down the slider to lock and make connection.

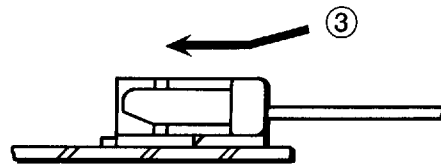
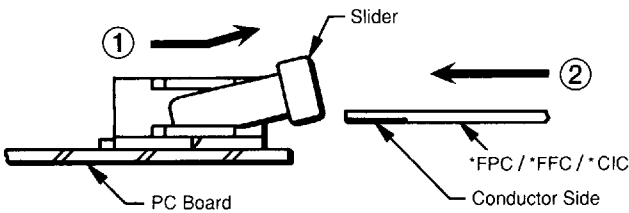

\*FPC = Flexible Printed Circuit  
\*FFC = Flexible Flat Cable  
\*CIC = Conductive Ink Circuit

■ RECOMMENDED FPC / FFC / CIC

FPC / CIC

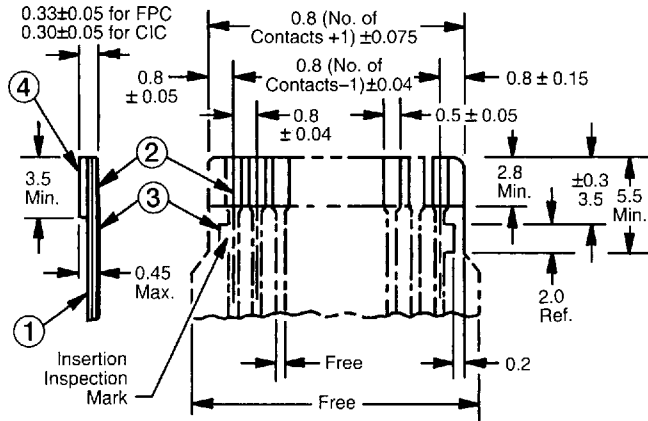

FFC

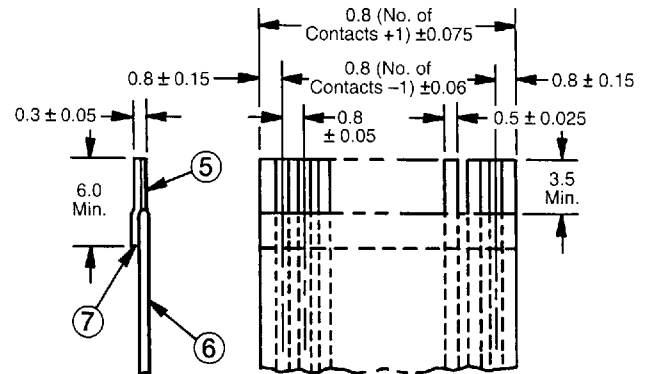

Bill of Materials for FPC / CIC

No.	Description
①	Base Film
②	Conductor, FPC—Copper (Tin or Solder plated 2µm Min). CIC—Carbon pasted over Silver pasted.
③	Cover Overlay
④	Supporting Tape

Bill of Materials for FFC

No.	Description
⑤	Conductor (Tin or Solder plated 2µm Min.)
⑥	Insulation
⑦	Supporting Tape

■ PLASTIC TAPE PACKAGED SURFLOK

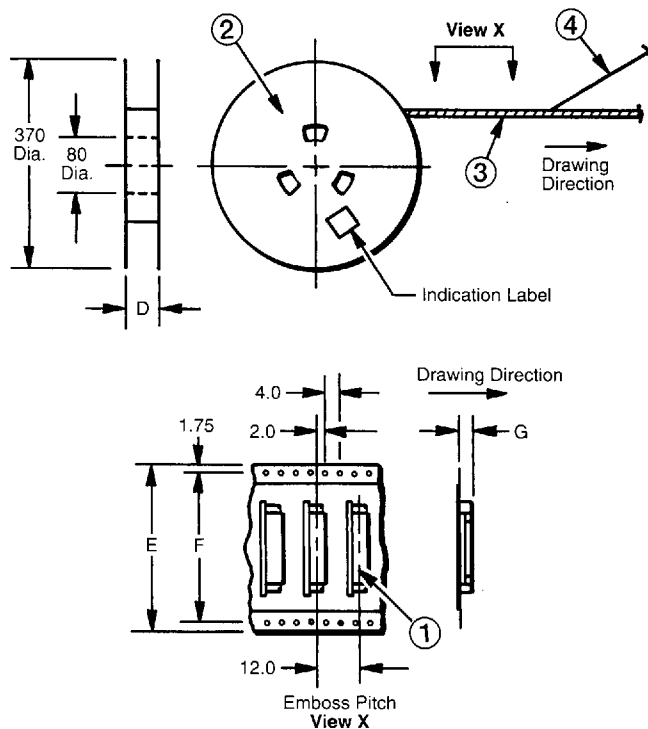

No. of Contacts	Catalog Number	Dimensions			
		D	E	F	G
4	SFR 4R-1/5STE1	22.4	16.0	—	3.35
6	SFR 6R-1/5STE1	22.4	16.0	—	3.35
8	SFR 8R-1/5STE1	30.4	24.0	—	3.45
10	SFR10R-1/5STE1	30.4	24.0	—	3.45
12	SFR12R-1/5STE1	30.4	24.0	—	3.45
14	SFR14R-1/5STE1	30.4	24.0	—	3.45
16	SFR16R-1/5STE1	30.4	24.0	—	3.45
18	SFR18R-1/5STE1	38.4	32.0	28.4	3.45
20	SFR20R-1/5STE1	38.4	32.0	28.4	3.45
22	SFR22R-1/5STE1	50.4	44.0	40.4	3.55
24	SFR24R-1/5STE1	50.4	44.0	40.4	3.55
26	SFR26R-1/5STE1	50.4	44.0	40.4	3.55
28	SFR28R-1/5STE1	50.4	44.0	40.4	3.55
30	SFR30R-1/5STE1	50.4	44.0	40.4	3.55

No.	Description	Material	Quantity
①	Connector		2000
②	Reel	Corrugated cardboard	1
③	Plastic Tape	Polypropylene	—
④	Cover Tape	Polyester	—

■ PC BOARD PATTERN

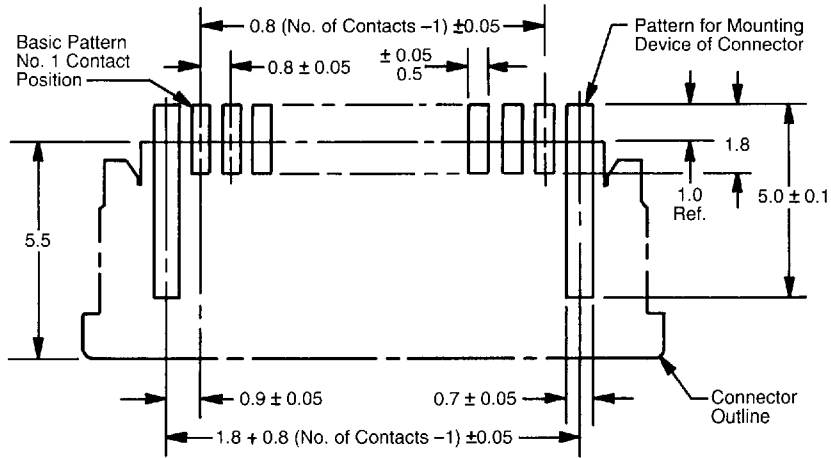

■ ORDERING INFORMATION

