

1. STUD TYPE THYRISTOR STACK

SINGLE-PHASE BRIDGE WITH 2 THYRISTORS ON LINE COMMON AC

SFR300L4BB1, SFR300U4BB2

The SFR300L4BB1 and SFR300U4BB2 series are thyristor stacks with two thyristors and two rectifier. They can be simply composed for single-phase control if a gate circuit is connected.

Current capacities for lines on a 220-V/440-V input voltage are available.

They are most suitable for thyristor-inverter power supply, DC motor-drive converter, DC constant-voltage and constant-current control.

MAXIMUM RATING

Type	Line Voltage V_{RMS} (Vrms)	Repetitive Peak Off-State Voltage and Reverse Voltage V_{DRM}, V_{RRM} (V)	Output Current I_o (A) $T_a = 60^\circ C$		Peak One-Cycle Surge Current (Non-Repetitive) I_{TSM} (A)	
			Free Convection	Air Velocity 5m/s	1 Cycle	10 Cycle
SFR16L4BB1	220	800	16	27	200	110
SFR30L4BB1	220	800	33	54	600	330
SFR50L4BB1	220	800	48	98	1000	560
SFR80L4BB1	220	800	80	155	1600	1300
SFR80U4BB2	440	1600				
SFR150L4BB1	220	800	135	265	3200	1800
SFR150U4BB2	440	1600				
SFR300L4BB1	220	800	155	390	5000	3100
SFR300U4BB2	440	1600				

Note : 1. Circuit Diagram

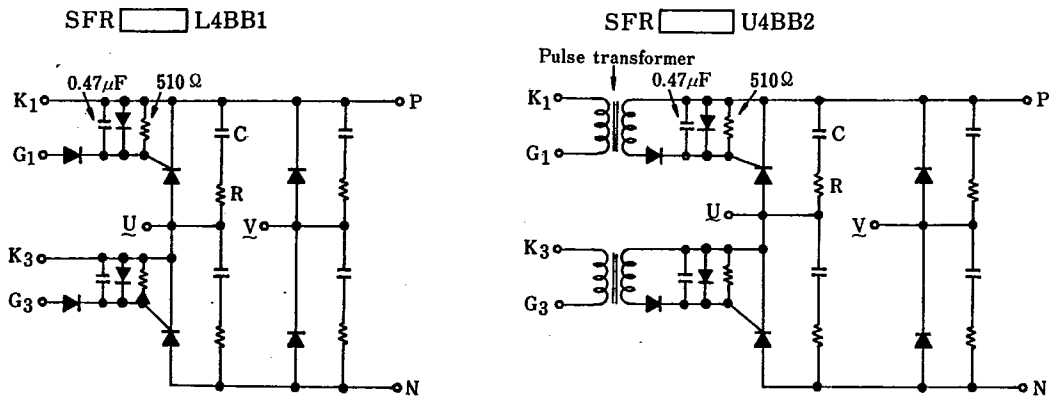

The stack with fuse is coded to the SFR 4BB3 series.

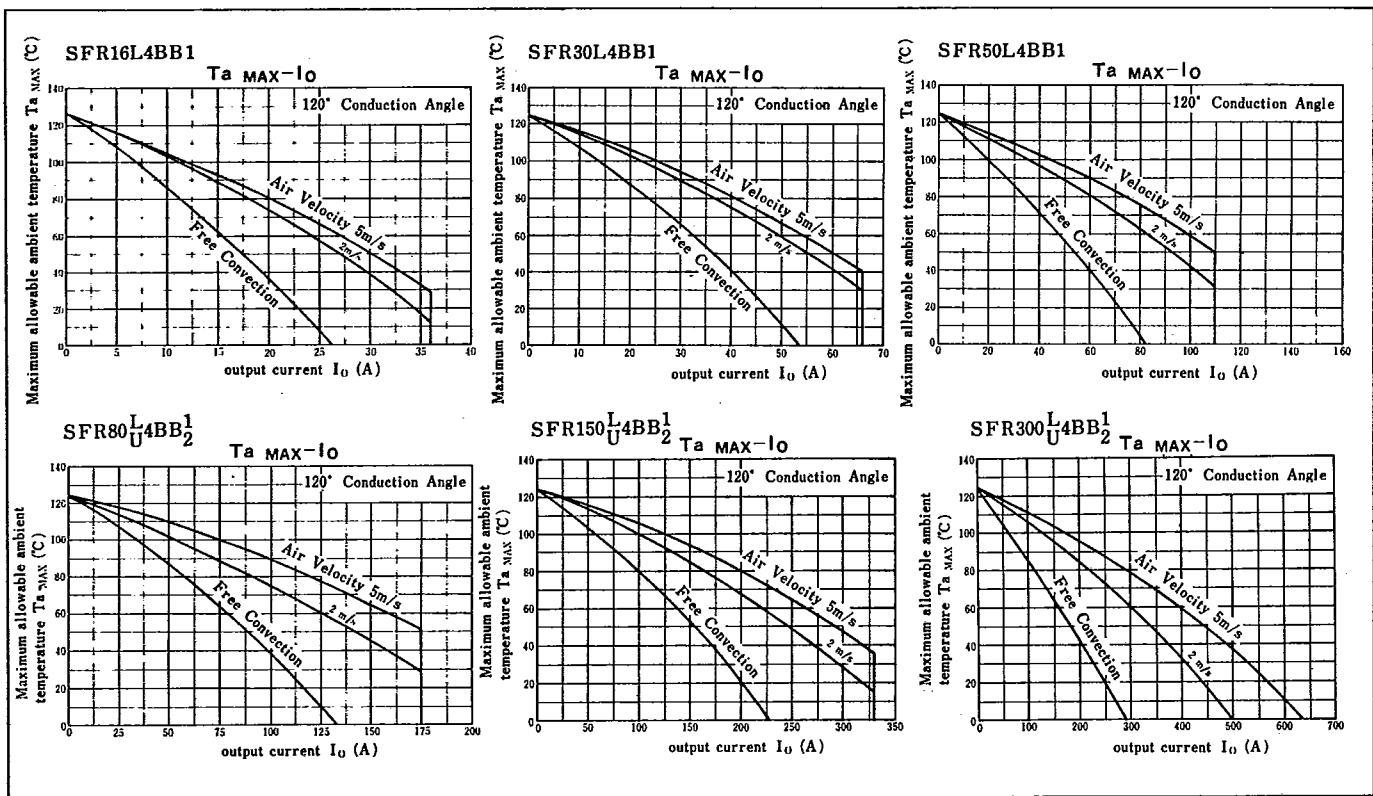

TABLE OF DIMENSIONS

Unit in mm

Type	L (MAX.)	L ₁	t	W (MAX.)	W ₁	H (MAX.)	H ₁	d	E
SFR16L4BB1	212	*192	6	244	224	170	50	6.5	4.5
SFR30L4BB1	212	*192	8	244	224	210	100	6.5	6.5
SFR50L4BB1	212	*192	8	244	224	210	100	6.5	6.5
SFR80L4BB1	286	133	8	286	266	230	115	6.5	6.5
SFR150L4BB1	286	133	10	286	266	270	130	8.5	8.5
SFR300L4BB1	286	133	10	286	266	270	130	8.5	8.5

