

OPERATIONAL AMPLIFIERS

DESCRIPTION

The SG107/207/307 is a general purpose internally compensated operational amplifier. It has excellent input bias current and drift characteristics in addition to short circuit protection and is pin compatible with industry standard operational amplifiers.

The SG107 is guaranteed and fully characterized over the full military ambient temperature range of -55°C to 125°C while the SG207 is electrically identical, except its performance is guaranteed from -25°C to 85°C. The 307 is designed for commercial applications of 0°C to 70°C.

FEATURES

- **Offset voltage 3mV maximum over temperature**
- **Input current 100nA maximum over temperature**
- **Offset current 20nA maximum over temperature**
- **Guaranteed drift characteristics**
- **Offsets guaranteed over entire common mode range**

HIGH RELIABILITY FEATURES - SG107

- ◆ **Available to MIL-STD - 883**
- ◆ **SG level "S" processing available**

SCHEMATIC DIAGRAM

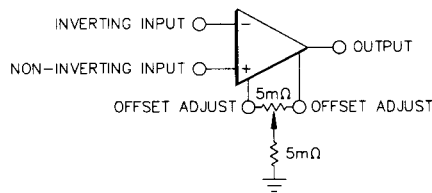
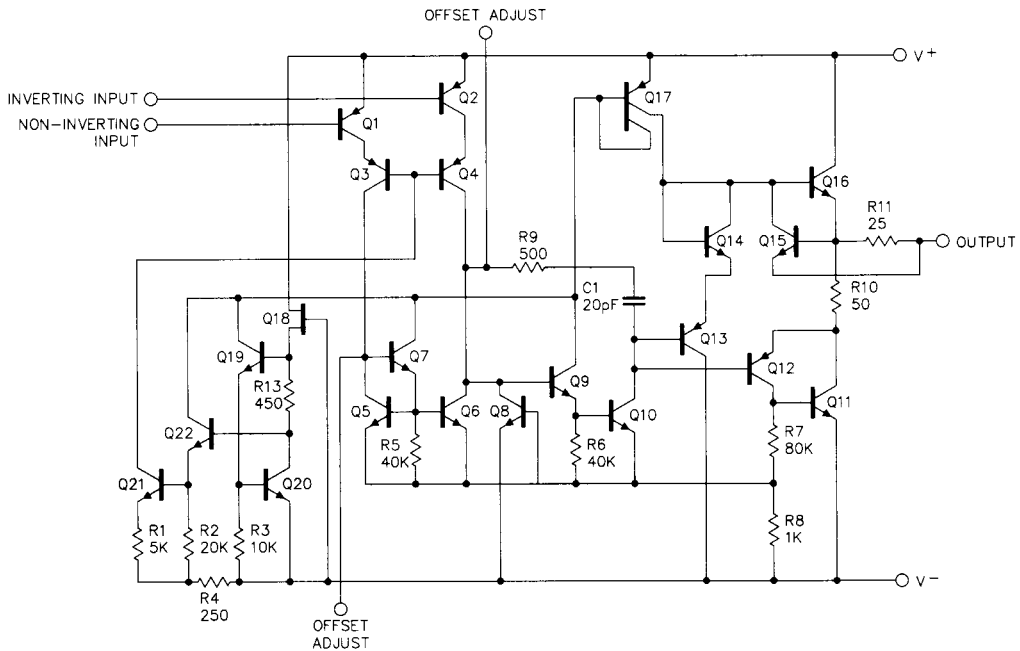

Optional Balancing Circuit

ABSOLUTE MAXIMUM RATINGS (Note 1)

Supply Voltage
 SG107/207 ±22V
 SG307 ±18V
 Differential Input Voltage ±30V
 Input Voltage (Note 2) ±15V

Operating Junction Temperature
 Hermetic (T, J, F Packages) 150°C
 Plastic (N Package) 150°C
 Storage Temperature Range -65°C to 150°C
 Output Short Circuit Duration (Note 3) Indefinite
 Lead Temperature (Soldering, 10 Seconds) 300°C

Note 1. Exceeding these ratings could cause damage to the device.
 Note 2. For supply voltages less than ±15V, the absolute maximum input voltage is equal to the supply voltage.
 Note 3. Continuous short circuit is allowed for case temperatures to 125°C and ambient temperatures to 70°C.

THERMAL DERATING CURVES

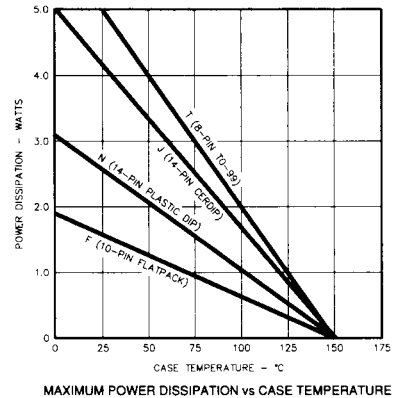
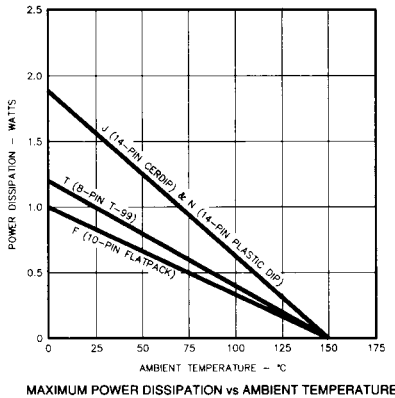

RECOMMENDED OPERATING CONDITIONS (Note 4)

Supply Voltage
 SG107/207 ±5V to ±20V
 SG307 ±5V to ±15V

Operating Ambient Temperature Range
 SG107 -55°C to 125°C
 SG207 -25°C to 85°C
 SG307 0°C to 70°C

Note 4. Range over which the device is functional.

ELECTRICAL SPECIFICATIONS

(Unless otherwise stated, these specifications apply for the operating ambient temperature of $T_A = 25^\circ\text{C}$ and for $\pm 5\text{V} \leq V_S \leq \pm 20\text{V}$. Low duty cycle pulse testing techniques are used which maintains junction and case temperatures equal to the ambient temperature.)

Parameter	Test Conditions	SG107/SG207			SG307			Units
		Min.	Typ.	Max.	Min.	Typ.	Max.	
Input Offset Voltage	$R_S \leq 50\text{K}\Omega$ $T_A = T_{\text{MIN}}$ to T_{MAX}	0.7	2.0		2.0	7.5		mV
				3.0		10.0		mV
Input Offset Current	$T_A = T_{\text{MIN}}$ to T_{MAX}	1.5	10		3.0	50		nA
				20		70		nA
Input Bias Current	$T_A = T_{\text{MIN}}$ to T_{MAX}	30	75		70	250		nA
				100		300		nA
Input Resistance (Note 5)		1.5	4		0.5	2		MΩ
				3.0				MΩ
Supply Current	$V_S = \pm 20\text{V}$ $V_S = \pm 15\text{V}$		1.8	3.0				mA
						1.8	3.0	
Large Signal Voltage Gain	$V_{\text{OUT}} = \pm 10\text{V}$, $V_S = \pm 15\text{V}$, $R_L \geq 2\text{K}\Omega$, $T_A = T_{\text{MIN}}$ to T_{MAX}	50	160		25	160		V/mV
		25			15			V/mV
Output Voltage Swing	$V_S = \pm 15\text{V}$, $R_L = 10\text{K}\Omega$ $V_S = \pm 15\text{V}$, $R_L = 2\text{K}\Omega$	±12	±14		±12	±14		V
		±10	±13		±10	±13		V
Input Voltage Range	$V_S = \pm 20\text{V}$, $T_A = T_{\text{MIN}}$ to T_{MAX} $V_S = \pm 15\text{V}$, $T_A = T_{\text{MIN}}$ to T_{MAX}	±15						V
					±12			V
Common Mode Rejection Ratio	$T_A = T_{\text{MIN}}$ to T_{MAX}	80	96		80	96		dB
Supply Voltage Rejection Ratio	$R_S \leq 10\text{K}\Omega$, $T_A = T_{\text{MIN}}$ to T_{MAX}	80	96		80	96		dB

ELECTRICAL SPECIFICATIONS (continued)

Parameter	Test Conditions	SG107/SG207			SG307			Units
		Min.	Typ.	Max.	Min.	Typ.	Max.	
Average Temperature Coefficient of Input Offset Voltage (Note 5)	$T_A = T_{MIN}$ to T_{MAX}		3.0	15		6.0	15	V/mV
Average Temperature Coefficient of Input Offset Current (Note 5)	$25^{\circ}\text{C} \leq T_A \leq 125^{\circ}\text{C}$		0.01	0.1			± 12	V
	$-55^{\circ}\text{C} \leq T_A \leq 25^{\circ}\text{C}$		0.02	0.2			± 10	V
	$25^{\circ}\text{C} \leq T_A \leq 70^{\circ}\text{C}$					0.01	± 12	V
	$0^{\circ}\text{C} \leq T_A \leq 25^{\circ}\text{C}$					0.02	80	dB
							80	dB

Note 5. These parameters, although guaranteed, are not tested in production.

CONNECTION DIAGRAMS & ORDERING INFORMATION (See Notes Below)

Package	Part No.	Ambient Temperature Range	Connection Diagram
14-PIN CERAMIC DIP J - PACKAGE	SG107J/883B SG107J SG207J SG307J	-55°C to 125°C -55°C to 125°C -25°C to 85°C 0°C to 70°C	
14-PIN PLASTIC DIP N - PACKAGE	SG207N SG307N	-25°C to 85°C 0°C to 70°C	
8-PIN METAL CAN T - PACKAGE	SG107T/883B SG107T SG207T SG307T	-55°C to 125°C -55°C to 125°C -25°C to 85°C 0°C to 70°C	
10-PIN CERAMIC FLAT PACK F - PACKAGE	SG107F/883B SG107F	-55°C to 125°C -55°C to 125°C	

Note 1. Contact factory for JAN and DESC product availability.
2. All packages are viewed from the top.