

## OFF-LINE START-UP CONTROLLER

### DESCRIPTION

The SG1540 is an integrated circuit designed to efficiently provide start-up power from a high-voltage DC bus to a PWM control circuit in a switching power supply. When used on the primary side, it reduces start-up current to less than 1mA and allows any standard PWM control circuit to be used as a primary-side controller. When used to power a controller on the secondary side, it efficiently eliminates the need for a heavy 50/60Hz line transformer with its associated low frequency magnetic fields.

The circuit consists of three sections: a micropower bandgap comparator/power switch referenced to 2.5 volts which isolates the start-up capacitor from its load; a high frequency square-wave oscillator with 200mA totem-pole output for driving an isolation transformer; and a second bandgap comparator with latching crowbar to protect against overvoltage faults while starting or running.

The SG1540 is specified for operation over the full military ambient temperature range of -55°C to 125°C. The SG2540 is characterized for the industrial range of -25°C to 85°C, and the SG3540 is designed for the commercial range of 0°C to 70°C.

### FEATURES

- Useable with primary and secondary side PWM controllers
- Micropower comparator / switch
  - Internal 2.5V bandgap reference
  - 50mA power switch
- Squarewave oscillator
  - 500Hz to 200KHz operation
  - 200mA totem pole outputs
- Eliminates bulky, expensive 50/60 Hz transformer
- Minimizes high voltage bleeder current
- Programmable start-up voltage and hysteresis
- Internal and programmable overvoltage crowbar latch
- Available in 8 pin DIP, 10 pin flat pack, and 16 pin widebody SOIC

### HIGH RELIABILITY FEATURES - SG1540

- ◆ Available to MIL-STD - 883
- ◆ LMI level "S" processing available

### BLOCK DIAGRAM

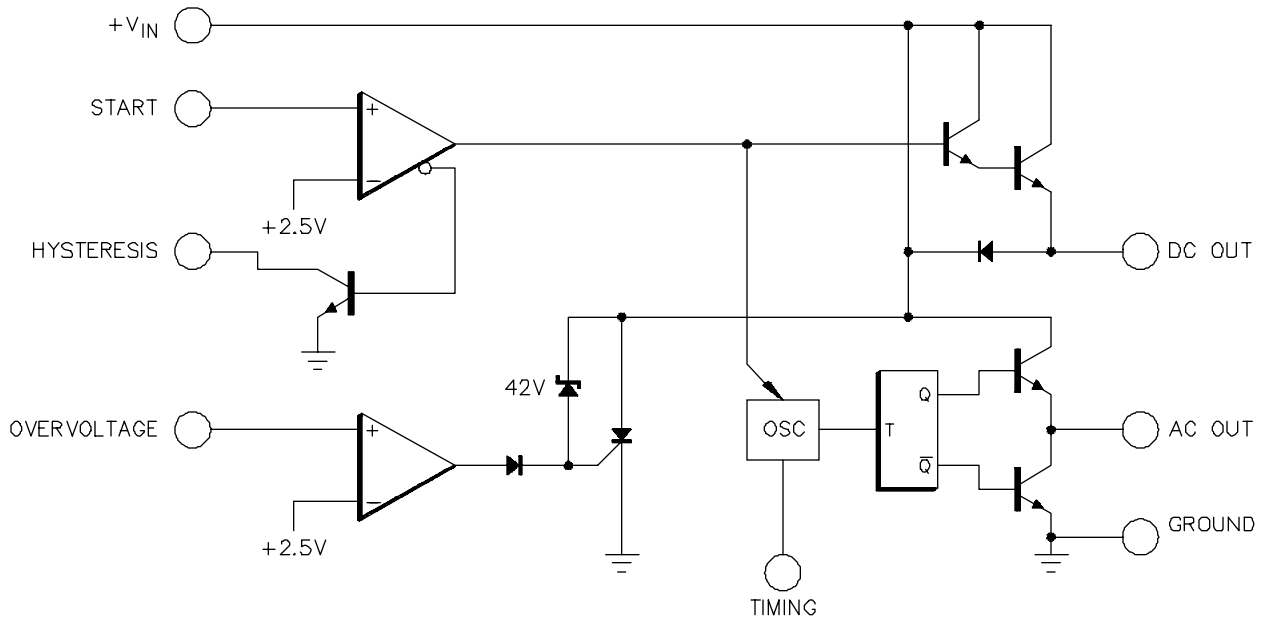

## ABSOLUTE MAXIMUM RATINGS (Note 1)

Supply Voltage (+V <sub>IN</sub> ) .....	+37V
DC Output Current, Continuous (V <sub>OUT</sub> ) .....	100mA
AC Output Current, Continuous .....	200mA
Analog Inputs (Start and Overvoltage) .....	-0.3V to 6.0V
Analog Input Currents (V>8V) .....	10mA
Overvoltage Crowbar Current, Continuous .....	50mA

Overvoltage Crowbar Energy (½CV²) .....	8mJ
Operating Junction Temperature	
Hermetic (Y Package) .....	150°C
Plastic (M, DW Packages) .....	150°C
Storage Temperature Range .....	-65°C to 150°C
Lead Temperature (Soldering, 10 Seconds) .....	300°C

Note 1. Values beyond which damage may occur.

## THERMAL DATA

Y Package:

Thermal Resistance-Junction to Case, θ <sub>JC</sub> .....	50°C/W
Thermal Resistance-Junction to Ambient, θ <sub>JA</sub> .....	130°C/W

M Package:

Thermal Resistance-Junction to Case, θ <sub>JC</sub> .....	60°C/W
Thermal Resistance-Junction to Ambient, θ <sub>JA</sub> .....	95°C/W

DW Package:

Thermal Resistance-Junction to Case, θ <sub>JC</sub> .....	40°C/W
Thermal Resistance-Junction to Ambient, θ <sub>JA</sub> .....	95°C/W

Note A. Junction Temperature Calculation:  $T_J = T_A + (P_D \times \theta_{JA})$ .

Note B. The above numbers for θ<sub>JC</sub> are maximums for the limiting thermal resistance of the package in a standard mounting configuration. The θ<sub>JA</sub> numbers are meant to be guidelines for the thermal performance of the device/pc-board system. All of the above assume no ambient airflow.

## RECOMMENDED OPERATING CONDITIONS (Note 2)

Supply Voltage Range .....	7V to 35V
DC Output Current, Continuous .....	0 to 50mA
AC Output Current, Continuous .....	0 to 100 mA
Oscillator Frequency Range .....	1KHz to 400KHz
Timing Resistor Range .....	2KΩ to 150KΩ

Timing Capacitor Range .....	1nF to 20μF
Operating Ambient Temperature Range	
SG1540 .....	-55°C to 125°C
SG2540 .....	-25°C to 85°C
SG3540 .....	0°C to 70°C

Note 2. Range over which the device is functional.

## ELECTRICAL CHARACTERISTICS

(Unless otherwise specified, these specifications apply over the operating ambient temperatures for SG1540 with -55°C ≤ T<sub>A</sub> ≤ 125°C, SG2540 with -25°C ≤ T<sub>A</sub> ≤ 85°C, SG3540 with 0°C ≤ T<sub>A</sub> ≤ 70°C, and +V<sub>IN</sub> = 15V. A 0.1μF high frequency bypass capacitor is recommended on V<sub>IN</sub>. Low duty cycle testing techniques are used which maintains junction and case temperatures equal to the ambient temperature.)

Parameter	Test Conditions	SG1540/2540/3540			Units
		Min.	Typ.	Max.	
<b>Start-up Section</b>					
Start Current I <sub>CC</sub>	V <sub>START</sub> = 0 to 2.37V		0.2	0.4	mA
Operating Current	V <sub>TIMING</sub> = +V <sub>IN</sub> ; V <sub>OUT</sub> Open		0.3	0.6	mA
	F <sub>OSC</sub> = 50KHz, V <sub>OUT</sub> and AC <sub>OUT</sub> Open		3	6	mA
Start Threshold		2.37	2.50	2.63	V
Start Bias Current	V <sub>PIN1</sub> = 0 to 5V		0.1	1	μA
Start Clamp Voltage	I <sub>PIN1</sub> = 1mA	6	7	8	V
Hysteresis ON Voltage	I <sub>PIN4</sub> = 100μA		0.1	0.2	V
<b>DC Output Section</b>					
V <sub>OUT</sub> Voltage	I <sub>SOURCE</sub> = 10mA	12.5	13.5		V
	I <sub>SOURCE</sub> = 50mA	12.0	13.0		V
Short Circuit Current	V <sub>OUT</sub> = 0V	50	100	225	mA

**ELECTRICAL CHARACTERISTICS** (continued)

Parameter	Test Conditions	SG1540/2540/3540			Units
		Min.	Typ.	Max.	
<b>Oscillator Section</b> (Note 3)					
Initial Accuracy	$T_J = 25^\circ\text{C}$	46	50	54	KHz
Voltage Stability	$+V_{IN} = 12 \text{ to } 18\text{V}$		5	12	%
Temperature Stability (Note 4)			2	5	%
Oscillator Minimum Frequency	$R_T = 17.8\text{K}, C_T = .068\mu\text{F}$			1	KHz
Oscillator Maximum Frequency	$R_T = 1.5\text{K}, C_T = 470\text{pF}$	400			KHz
<b>AC Output Section</b>					
HIGH Output Voltage	$I_{SOURCE} = 20\text{mA}$	12.5	13.5		V
	$I_{SOURCE} = 100\text{mA}$	12.0	13.0		V
LOW Output Voltage	$I_{SINK} = 20\text{mA}$		0.2	0.3	V
	$I_{SINK} = 100\text{mA}$		1.2	2.0	V
Squarewave Duty Cycle		45	50	55	%
AC Output Risetime	$C_L = 1000\text{pF}$		0.3	0.6	$\mu\text{S}$
AC Output Falltime	$C_L = 1000\text{pF}$		0.1	0.2	$\mu\text{S}$
<b>Overvoltage Crowbar Section</b>					
Overvoltage Threshold		2.37	2.50	2.63	V
Overvoltage Bias Current	$V_{O.V.} = 0 \text{ to } 2.37\text{V}$		0.1	1	$\mu\text{A}$
Overvoltage Clamp Voltage	$I_{O.V.} = 1\text{mA}$	6	7	8	V
$+V_{IN}$ Overvoltage Threshold		37	42	44	V
SCR ON Voltage	$I_{VIN} = 35\text{mA}$		9	12	V
SCR Holding Current	$V_{O.V.} = 0$	0.15	0.35	0.55	mA

Note 3.  $F_{OSC} = 50\text{KHz}$ ,  $R_T = 3.48\text{K}$   $C_T = 4.7\text{nF}$  unless otherwise specified.  
 Note 4. These parameters, although guaranteed, are not tested in production.

**CHARACTERISTIC CURVES**

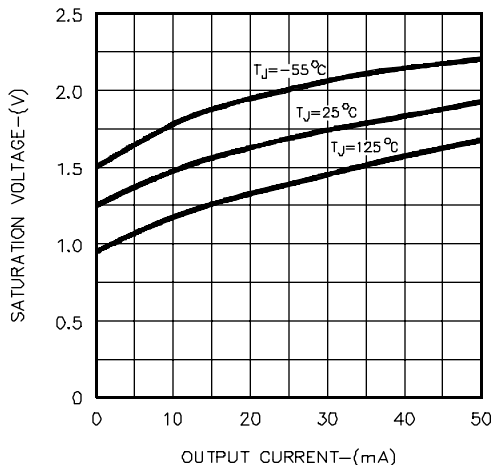

FIGURE 1 - SATURATION VOLTAGE (DC OUT PIN) VS. OUTPUT CURRENT

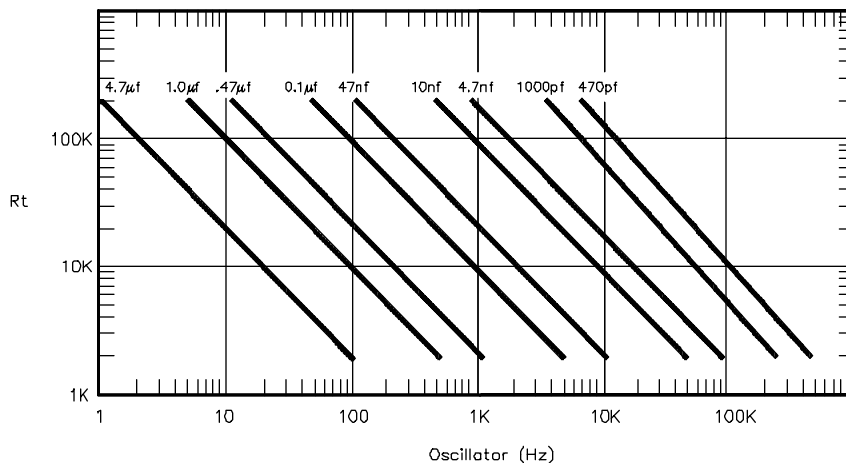

FIGURE 2 - OSCILLATOR FREQUENCY VS.  $R_T$  AND  $C_T$

**APPLICATION INFORMATION**

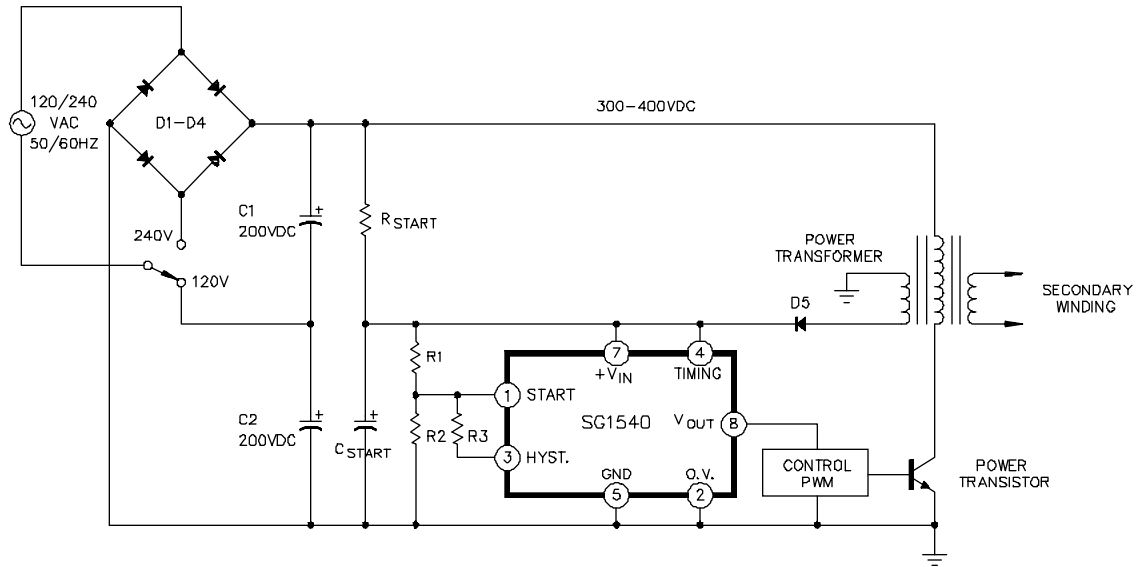

FIGURE 3 - EFFICIENT PRIMARY SIDE START-UP

**PRIMARY SIDE START-UP**

When the design goal is efficient start-up for a control PWM referenced to the primary side of the power transformer, the configuration in Figure 3 is recommended. An energy storage capacitor  $C_{START}$  is trickle-charged from the 300-400 Volt DC bus by resistor  $R_{START}$ . The value of  $R_{START}$  is chosen to provide a constant 1mA charging current, allowing the use of a ½ watt resistor. As the voltage on  $C_{START}$  ramps up from zero, the only load current is the standby current of the SG1540 and that of the divider network R1-R3. (Connecting the TIMING pin to  $+V_{IN}$  disables the internal power oscillator and forces the circuitry into a micropower standby model. Since the input bias current at the START pin is 1µA maximum, a divider current of 100µA is adequate).

When the voltage at the START pin reaches +2.5 Volts, the hysteresis transistor turns off, overdriving the START pin. The  $V_{OUT}$  pin is switched to the HIGH state, providing power to the PWM control circuit. As energy flows out of the START capacitor, its voltage decays; but it remains connected to the PWM circuit until the dropout voltage is reached ( $V_{START} - V_{HYSTERESIS}$ ). The bootstrap winding on the power transformer and rectifier diode D5 prevent this from happening. As the PWM control circuit becomes active, the power transistor begins to switch, providing operating current to the PWM circuit through the SG1540.

**RESISTOR CALCULATIONS**

Given that  $V_{START}$  and  $V_{DROPOUT}$  have been chosen, and that the divider current at start-up is 100µA, then the values for R1 through R3 are calculated as follows:

$$\begin{aligned}
 1. \text{ For simplification, let } X &= \frac{V_{START} - 2.5}{2.5} & 2. \text{ Then, } R1 &= 2.5 \times 10^4 * X & [1] \\
 & & R2 &= R1/Y & [2] \\
 \text{and } Y &= \frac{V_{DROPOUT} - 2.5}{2.5} & \text{and } R3 &= \frac{R1 * R2}{X * R2 - R1} & [3]
 \end{aligned}$$

**DESIGN EXAMPLE**

Suppose we have a power MOSFET device, and so want to start at +18 volts and drop out at +12 volts.

Then  $X = 6.20$   
and  $Y = 3.80$

Therefore  $R1 = 2.5 \times 10^4 * 6.2 = 155K$  (Choose 150K)  
 $R2 = 1.5 \times 10^5 / 3.8 = 39.5K$  (Choose 39K)

$R3 = \frac{1.5 \times 10^5 * 3.9 \times 10^4}{6.2 * 3.9 \times 10^4 - 1.5 \times 10^5} = 63.7K$  (Choose 62K)

**APPLICATIONS INFORMATION** (continued)

The voltage waveform at  $+V_{IN}$  is shown in Figure 4 with these resistor values and with  $C_{START} = 3\mu F$ . Notice that two tries are required before the +15 volt bootstrap winding becomes active.

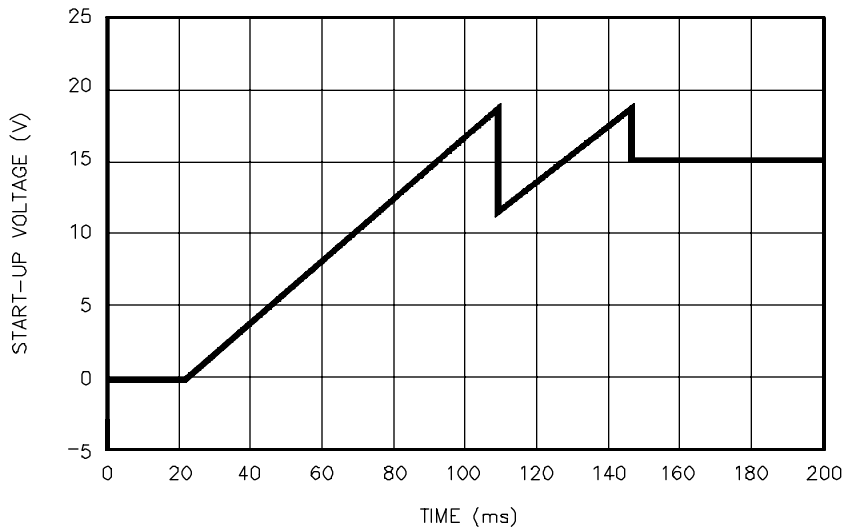

FIGURE 4 - STARTUP VOLTAGE WAVEFORM

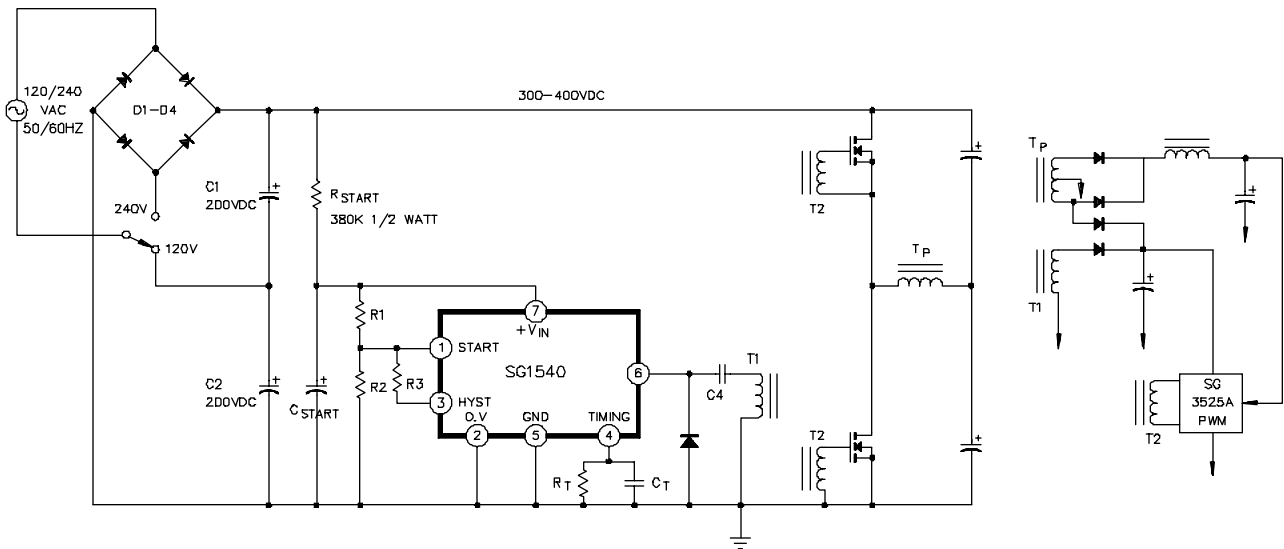

FIGURE 5 - SECONDARY-SIDE START-UP WITHOUT A LINE TRANSFORMER

## CONNECTION DIAGRAMS & ORDERING INFORMATION (See Notes Below)

Package	Part No.	Ambient Temperature Range	Connection Diagram
8-PIN CERAMIC DIP Y - PACKAGE	SG1540Y/883B	-55°C to 125°C	
	SG1540Y	-55°C to 125°C	
	SG2540Y	-25°C to 85°C	
	SG3540Y	0°C to 70°C	
8-PIN PLASTIC DIP M - PACKAGE	SG2540M	-25°C to 85°C	
	SG3540M	0°C to 70°C	
16-PIN WIDE BODY PLASTIC S.O.I.C. DW - PACKAGE	SG2540DW	-25°C to 85°C	
	SG3540DW	0°C to 70°C	

Notes: 1. Contact factory for JAN and DESC part availability.  
2. All parts are viewed from the top.