

Highly Integrated Green-Mode PWM Controller

SG5842A/JA

FEATURES

- Green-Mode PWM Controller
- Low Start-up Current (14μA)
- Low Operating Current (4mA)
- Programmable PWM Frequency with Hopping (5842JA)
- Peak-Current-Mode Control
- Cycle-by-Cycle Current Limiting
- Synchronized Slope Compensation
- Leading-Edge Blanking
- Constant Output Power Limit
- Totem Pole Output with Soft Driving
- V_{DD} Over-Voltage Protection (OVP)
- Programmable Over-Temperature Protection (OTP)
- Internal Latch Circuit (OTP, OVP)
- Internal Open-Loop Protection
- V_{DD} Under-Voltage Lockout (UVLO)
- GATE Output Maximum Voltage Clamp (18V)

APPLICATIONS

General-purpose switch mode power supplies and flyback power converters, including:

- Notebook Power Adapters
- Open-Frame SMPS

DESCRIPTION

The highly integrated SG5842A/JA series of PWM controllers provides several features to enhance the performance of flyback converters.

To minimize standby power consumption, a proprietary green-mode function provides off-time modulation to continuously decrease the switching frequency at light-load conditions. To avoid acoustic-noise problem, the minimum PWM frequency set above 22KHz. This green-mode function enables the power supply to meet international power conservation requirements. To further reduce power consumption, SG5842A/JA is manufactured using the BiCMOS process. This allows a low start-up current, around 14μA, and an operating current of only 4mA. As a result, a large start-up resistance can be used.

The SG5842A/JA built-in synchronized slope compensation achieves stable peak-current-mode control.

SG5842JA integrates a frequency hopping function that helps reduce EMI emission of a power supply with minimum line filters.

SG5842A/JA provides many protection functions. In addition to cycle-by-cycle current limiting, the internal open-loop protection circuit ensures safety should an open loop or output short-circuit failure occur. PWM output is disabled until V_{DD} drops below the UVLO lower limit, then the controller starts again. As long as V_{DD} exceeds about 24V, the internal OVP circuit is triggered. An external NTC thermistor can be applied for over-temperature protection.

SG5842A/JA is available in an 8-pin DIP or SOP package.

TYPICAL APPLICATION

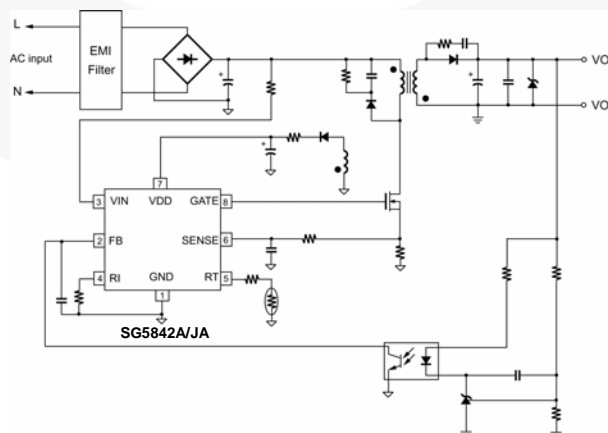

Highly Integrated Green-Mode PWM Controller

SG5842A/JA

MARKING DIAGRAMS

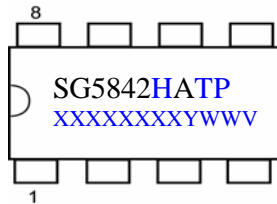

H: J = with Frequency Hopping
Null = without Frequency Hopping
T: D = DIP, S = SOP
P: Z = Lead Free
Null = regular package
XXXXXXXXXX: Wafer Lot
Y: Year; WW: Week
V: Assembly Location

PIN CONFIGURATION

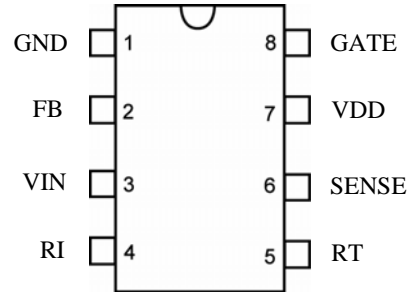

ORDERING INFORMATION

Part Number	OTP Latch	OVP Latch	Frequency Hopping	Pb-Free	Package
SG5842JASZ	Yes	Yes	Yes		8-Pin SOP
SG5842JADZ	Yes	Yes	Yes		8-Pin DIP
SG5842ASZ (Preliminary)	Yes	Yes	No		8-Pin SOP
SG5842ADZ (Preliminary)	Yes	Yes	No		8-Pin DIP

PIN DESCRIPTIONS

Pin No.	Symbol	Function	Description
1	GND	Ground	Ground.
2	FB	Feedback	The signal from the external compensation circuit is fed into this pin. The PWM duty cycle is determined in response to the signal from this pin and the current-sense signal from Pin 6. If FB voltage exceeds the threshold, the internal protection circuit disables PWM output after a predetermined delay time.
3	VIN	Start-up Input	For start-up, this pin is pulled high to the rectified line input via a resistor. Since the start-up current requirement of the SG5842A/JA is very small, a large start-up resistance can be used to minimize power loss.
4	RI	Reference Setting	A resistor connected from the RI pin to GND pin provides a constant current source. This determines the center PWM frequency. Increasing the resistance reduces PWM frequency. Using a 26KΩ resistor results in a 65KHz center PWM frequency.
5	RT	Temperature Detection	For over-temperature protection. An external NTC thermistor is connected from this pin to the GND pin. The impedance of the NTC decreases at high temperatures. Once the voltage of the RT pin drops below a fixed limit, PWM output is latched off.
6	SENSE	Current Sense	Current sense. The sensed voltage is used for peak-current-mode control and cycle-by-cycle current limiting.
7	VDD	Power Supply	Power supply. The internal protection circuit disables PWM output if V _{DD} is over-voltage.
8	GATE	Driver Output	The totem-pole output driver for the power MOSFET, which is internally clamped below 18V.

Highly Integrated Green-Mode PWM Controller

SG5842A/JA

BLOCK DIAGRAM

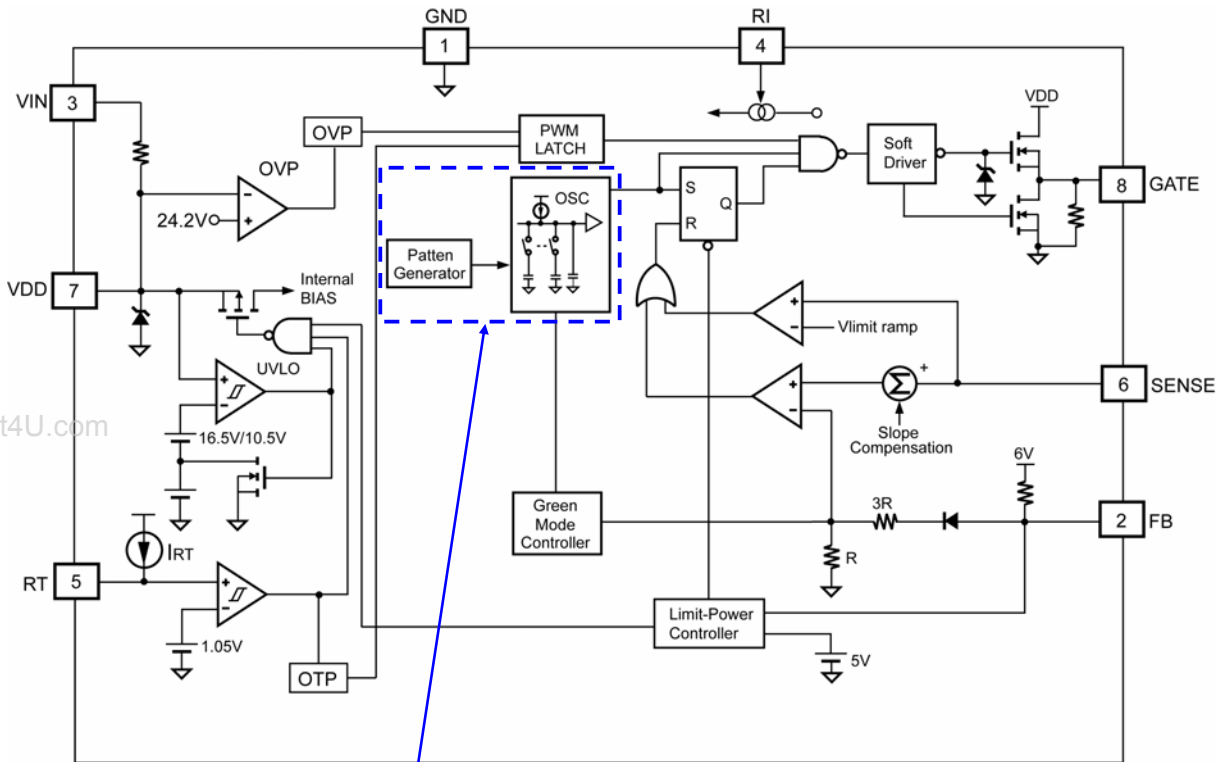

5842JA only

www.DataSheet4U.com

Highly Integrated Green-Mode PWM Controller

SG5842A/JA

ABSOLUTE MAXIMUM RATINGS

Symbol	Parameter	Value	Unit
V _{VDD}	Supply Voltage	30	V
V _{VIN}	Input Terminal	30	V
V _{FB}	Input Voltage to FB Pin	-0.3 to 7.0	V
V _{SENSE}	Input Voltage to SENSE Pin	-0.3 to 7.0	V
V _{RT}	Input Voltage to RT Pin	-0.3 to 7.0	V
V _{RI}	Input Voltage to RI Pin	-0.3 to 7.0	V
P _D	Power Dissipation (T _A < 50°C)	DIP	800.0
		SOP	400.0
R _{θJA}	Thermal Resistance (Junction-to-Air)	DIP	82.5
		SOP	141.0
T _J	Operating Junction Temperature	-40 to +125	°C
T _{STG}	Storage Temperature Range	-55 to +150	°C
T _L	Lead Temperature (Wave Soldering or Infrared, 10 Seconds)	260	°C
V _{ESD,HBM}	Electrostatic Discharge Capability, Human Body Model	3.0	KV
V _{ESD,MM}	Electrostatic Discharge Capability, Machine Model	250	V

* All voltage values, except differential voltages, are given with respect to GND pin.

* Stresses beyond those listed under "absolute maximum ratings" may cause permanent damage to the device.

RECOMMENDED OPERATING CONDITIONS

Symbol	Parameter	Value	Unit
T _A	Operating Ambient Temperature	-20 to +85	°C

* For proper operation.

ELECTRICAL CHARACTERISTICS

V_{DD} = 15V, T_A = 25°C, unless otherwise noted.

V_{DD} Section

Symbol	Parameter	Test Condition	Min.	Typ.	Max.	Unit
V _{DD-OP}	Continuously Operating Voltage				20	V
V _{DD-ON}	Start Threshold Voltage		15.5	16.5	17.5	V
V _{DD-OFF}	Minimum Operation Voltage		9.5	10.5	11.5	V
I _{DD-ST}	Start-up Current	V _{DD} =V _{DD-ON} -0.16V		14	30	μA
I _{DD-OP}	Operating Supply Current	V _{DD} =15V, R _I =26KΩ, GATE=OPEN		4	5	mA
V _{DD-OVP}	V _{DD} Over-Voltage Protection		23.2	24.2	25.2	V
t _{D-OVP}	V _{DD} Over-Voltage Protection Debounce Time	R _I =26KΩ		100		μs
I _{DD-H}	Holding Current After OVP/OTP Latch-up	V _{DD} =5V	40.0	52.5	65.0	μA

R_I Section

Symbol	Parameter	Test Condition	Min.	Typ.	Max.	Unit
R _{I-NOR}	R _I Operating Range		15.5		36.0	KΩ
R _{I-MAX}	Maximum R _I Value for Protection			230		KΩ
R _{I-MIN}	Minimum R _I Value for Protection			10		KΩ

Highly Integrated Green-Mode PWM Controller

SG5842A/JA

Oscillator Section

Symbol	Parameter	Test Condition	Min.	Typ.	Max.	Unit	
F _{OSC}	Normal PWM Frequency	Center Frequency	R _I =26KΩ	62	65	68	KHz
		Hopping Range	R _I =26KΩ (5842JA only)	±3.7	±4.2	±4.7	
t _{HOP}	Hopping Period	R _I =26KΩ (5842JA only)	3.9	4.4	4.9	ms	
F _{OSC-G}	Green-Mode Minimum Frequency	R _I =26KΩ	18	22	25	KHz	
F _{DV}	Frequency Variation vs. V _{DD} Deviation	V _{DD} =11.5V to 20V			5	%	
F _{DT}	Frequency Variation vs. Temperature Deviation	T _A =-20 to 85°C			5	%	

Feedback Input Section

Symbol	Parameter	Test Condition	Min.	Typ.	Max.	Unit
A _V	FB Input to Current Comparator Attenuation		1/4.5	1/4.0	1/3.5	V/V
Z _{FB}	Input Impedance		4		7	KΩ
V _{FB-OPEN}	Output High Voltage	FB pin open	5.5			V
V _{FB-OLP}	FB Open-Loop Trigger Level		5.0		5.4	V
t _{D-OLP}	FB Open-Loop Protection Delay	R _I =26KΩ	50	56	62	ms
V _{FB-N}	Green-Mode Entry FB Voltage	R _I =26KΩ	1.9	2.1	2.3	V
V _{FB-G}	Green-Mode Ending FB Voltage	R _I =26KΩ		V _{FB-N} -0.5		V

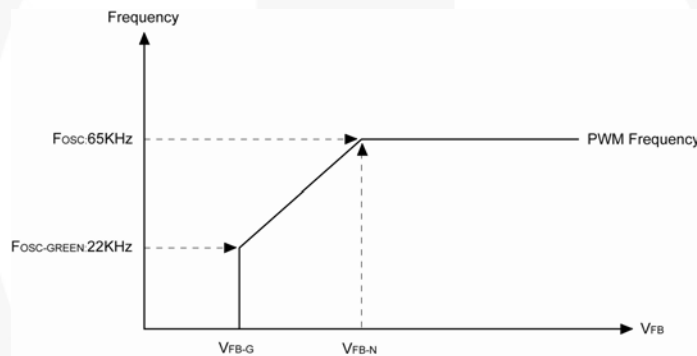

Current Sense Section

Symbol	Parameter	Test Condition	Min.	Typ.	Max.	Unit
Z _{SENSE}	Input Impedance			12		KΩ
V _{STHFL}	Current Limit Flatten Threshold Voltage		0.85	0.90	0.95	V
V _{STHVA}	Current Limit Valley Threshold Voltage	V _{STHFL} -V _{STHVA}		0.22		V
DCY _{SAW}	Duty Cycle of SAW Limit	Maximum Duty Cycle		45		%
t _{PD}	Propagation Delay to GATE Output	R _I =26KΩ		150	200	ns
t _{LEB}	Leading-Edge Blanking Time	R _I =26KΩ	200	270	350	ns

Highly Integrated Green-Mode PWM Controller

SG5842A/JA

GATE Section

Symbol	Parameter	Test Condition	Min.	Typ.	Max.	Unit
DCY _{MAX}	Maximum Duty Cycle		60	65	70	%
V _{GATE-L}	Output Voltage Low	V _{DD} =15V, I _O =50mA			1.5	V
V _{GATE-H}	Output Voltage High	V _{DD} =12.5V, I _O =-50mA	7.5			V
t _r	Rising Time	V _{DD} =15V, C _L =1nF	150	250	350	ns
t _f	Falling Time	V _{DD} =15V, C _L =1nF	30	50	90	ns
I _O	Peak Output Current	V _{DD} =15V, GATE=6V	230			mA
V _{GATE-CLAMP}	Gate Output Clamping Voltage	V _{DD} =20V		18	19	V

RT Section

Symbol	Parameter	Test Condition	Min.	Typ.	Max.	Unit
I _{RT}	Output Current of RT Pin	R _I =26KΩ	67	70	73	μA
V _{RTTH}	Over-Temperature Protection Threshold Voltage		1.015	1.050	1.085	V
t _{D-OTP}	Over-Temperature Debounce	R _I =26KΩ	60	100	140	μs

TYPICAL CHARACTERISTICS

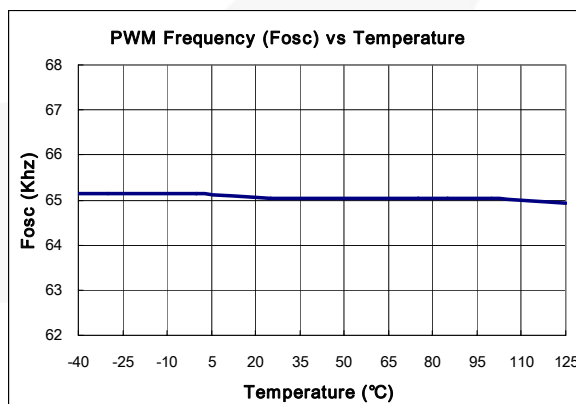
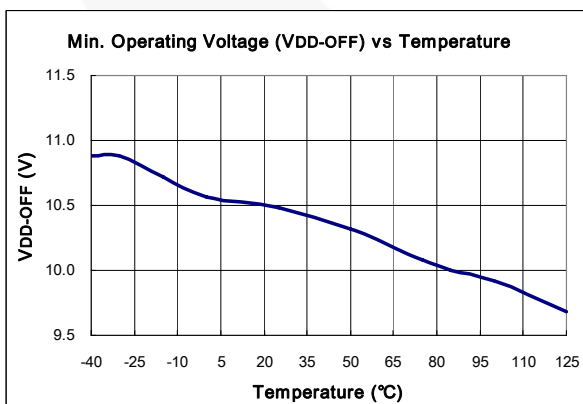
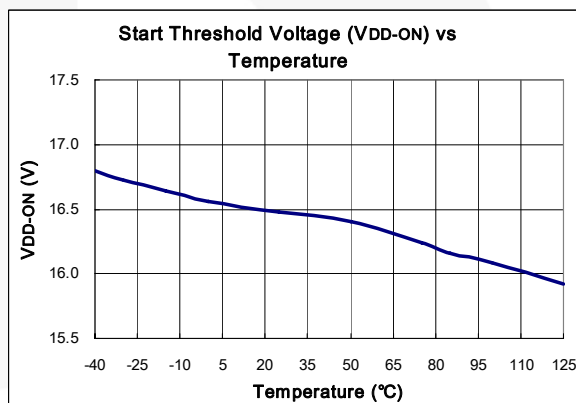
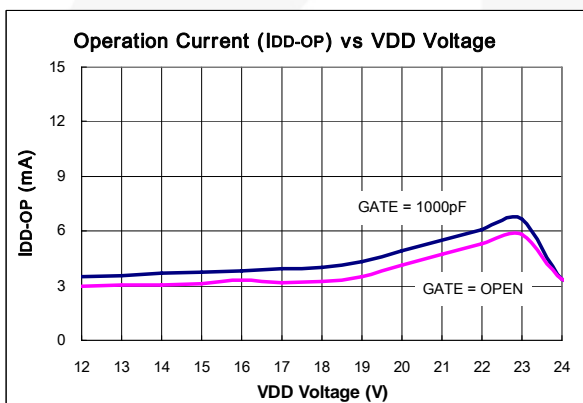
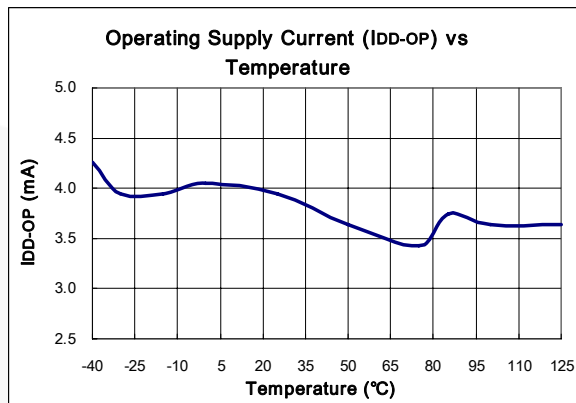
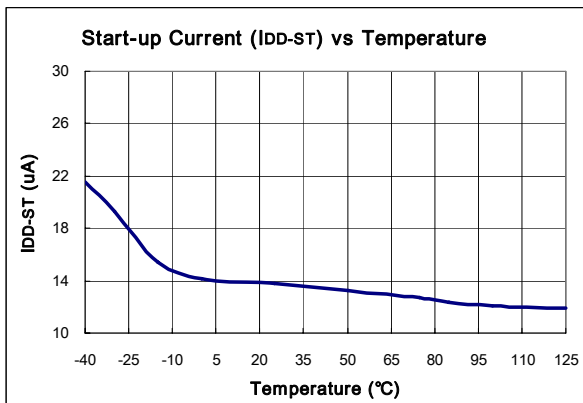

Highly Integrated Green-Mode PWM Controller

SG5842A/JA

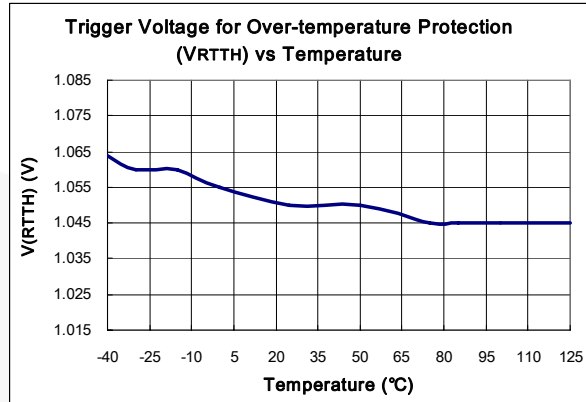
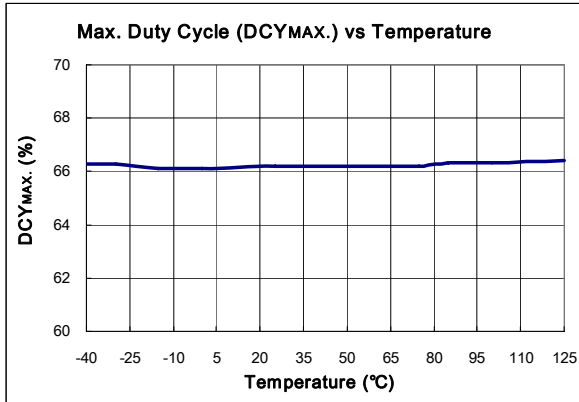

www.DataSheet4U.com

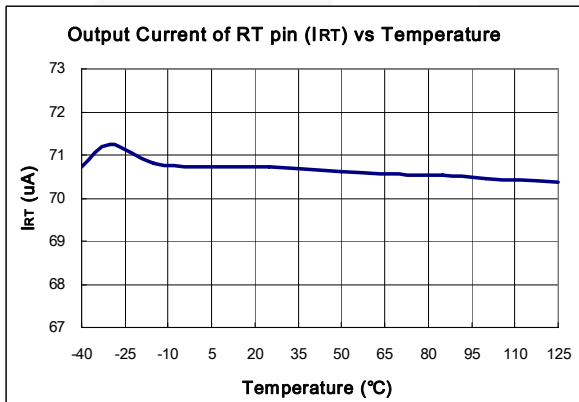

OPERATION DESCRIPTION

Start-up Current

The typical start-up current is only 14μA, which allows a high-resistance, low-wattage start-up resistor to be used to minimize power loss. A 1.5MΩ, 0.25W, start-up resistor and a 10μF/25V V_{DD} hold-up capacitor are sufficient for an AC/DC adapter with a universal input range.

Operating Current

The required operating current has been reduced to 4mA. This results in higher efficiency and reduces the V_{DD} hold-up capacitance requirement.

Green-Mode Operation

The proprietary green-mode function provides off-time modulation to continuously decrease the PWM frequency under light-load conditions. To avoid acoustic noise problems, the minimum PWM frequency is set above 22KHz. This green-mode function dramatically reduces power consumption under light-load and zero-load conditions. Power supplies using a SG5842A/JA controller can meet even the most restrictive international regulations regarding standby power consumption.

Oscillator Operation

A resistor connected from the RI pin to the GND pin generates a constant current source for the SG5842A/JA controller. This current is used to determine the center PWM frequency. Increasing the resistance reduces PWM frequency. Using a 26KΩ resistor, R_I, results in a corresponding 65KHz PWM frequency. The relationship between R_I and the switching frequency is:

$$f_{PWM} = \frac{1690}{R_I (K\Omega)} (KHz) \quad (1)$$

The range of the PWM oscillation frequency is designed as 47KHz ~ 109KHz.

SG5842JA also integrates frequency hopping function internally. The frequency variation ranges from around 62KHz to 68KHz for a center frequency of 65KHz. The frequency hopping function helps reduce EMI emission of a power supply with minimum line filters.

Leading-Edge Blanking

Each time the power MOSFET is switched on, a turn-on spike occurs at the sense-resistor. To avoid premature termination of the switching pulse, a leading-edge blanking time is built in. During this blanking period, the current-limit comparator is disabled and cannot switch off the gate drive.

Under-Voltage Lockout (UVLO)

The turn-on/turn-off thresholds are fixed internally at 16.5V/10.5V. To enable a SG5842A/JA controller during start-up, the hold-up capacitor must first be charged to 16.5V through the start-up resistor.

The hold-up capacitor continues to supply V_{DD} before energy can be delivered from the auxiliary winding of the main transformer. V_{DD} must not drop below 10.5V during this start-up process. This UVLO hysteresis window ensures that the hold-up capacitor can adequately supply V_{DD} during start-up.

Gate Output / Soft Driving

The SG5842A/JA BiCMOS output stage is a fast totem pole gate driver. Cross-conduction has been avoided to minimize heat dissipation, increase efficiency, and enhance reliability. The output driver is clamped by an internal 18V Zener diode to protect the power MOSFET transistors from any harmful over-voltage gate signals. A soft driving waveform is implemented to minimize EMI.

Slope Compensation

The sensed voltage across the current sense resistor is used for peak-current-mode control and cycle-by-cycle current limiting. The built-in slope compensation function improves power supply stability and prevents peak-current-mode control from causing sub-harmonic oscillations. Within every switching cycle, the SG5842A/JA controller produces a positively sloped, synchronized ramp signal.

Highly Integrated Green-Mode PWM Controller

SG5842A/JA

Constant Output Power Limit

When the SENSE voltage, across the sense resistor R_S , reaches the threshold voltage, around 0.85V, the output GATE drive is turned off after a small delay t_{PD} . This delay introduces additional current, proportional to $t_{PD} \cdot V_{IN} / L_P$. Since the delay is nearly constant regardless of the input voltage V_{IN} . Higher input voltage results in a larger additional current and the output power limit is also higher than under low input line voltage. To compensate this variation for a wide AC input range, a sawtooth power-limiter (saw limiter) is designed to solve the unequal power-limit problem. The saw limiter is designed as a positive ramp signal (V_{LIMIT_RAMP}) and is fed to the inverting input of the OCP comparator. This results in a lower current limit at high-line inputs than at low-line inputs.

V_{DD} Over-Voltage Protection

V_{DD} over-voltage protection has been built in to prevent damage due to abnormal conditions. Once the V_{DD} voltage is over than the V_{DD} over-voltage protection voltage (V_{DD-OVP}) and lasts for t_{D-OVP} , the PWM pulses is latched off. The PWM pulses stay latched off until the user unplugs the power supply from the mains outlet.

Limited Power Control

The FB voltage increases every time the output of the power supply is shorted or over loaded. If the FB voltage remains higher than a built-in threshold longer than t_{D-OLP} , PWM output is turned off. As PWM output is turned off, the supply voltage V_{DD} begins decreasing.

$$t_{D-OLP} \text{ (ms)} = 2.154 \times R_1 \text{ (K}\Omega\text{)} \quad \text{-----} \quad (2)$$

When V_{DD} goes below the turn-off threshold (eg, 10.5V) the controller is totally shut down. V_{DD} is charged up to the turn-on threshold voltage of 16.5V through the start-up resistor until PWM output is restarted. This protection feature remains activated as long as the over-loading condition persists. This prevents the power supply from overheating due to over loading conditions.

Protection Latch Circuit

For the SG5842A/JA family, the built-in latch function provides a versatile protection feature that does not require external components (*see ordering information for a detailed description*). To reset the latch circuit, disconnect the AC line voltage of the power supply.

Thermal Protection

An external NTC thermistor can be connected from the RT pin to ground. A fixed current, I_{RT} , is sourced from the RT pin. Because the impedance of the NTC decreases at high temperatures, when the voltage of the RT pin drops below 1.05V, PWM output is latched off. The RT pin output current is related to the PWM frequency programming resistor R_1 .

Noise Immunity

Noise from the current sense or the control signal may cause significant pulse width jitter, particularly in continuous-conduction mode. Slope compensation helps alleviate this problem. Good placement and layout practices should be followed. Avoid long PCB traces and component leads. Compensation and filter components should be located near the SG5842A/JA. Finally, increasing the power-MOS gate resistance is advised.

Highly Integrated Green-Mode PWM Controller

SG5842A/JA

REFERENCE CIRCUIT

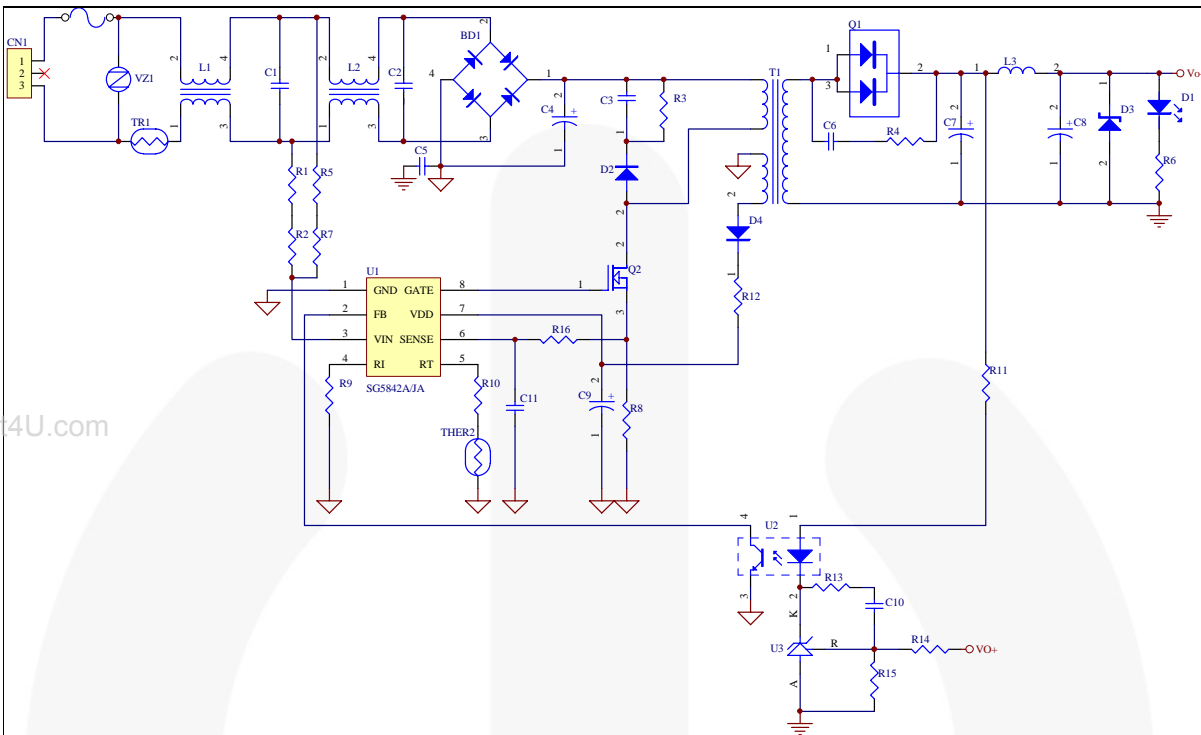

BOM

Reference	Component	Reference	Component
BD1	BD 4A/600V	Q2	MOS 7A/600V
C1	XC 0.68μF/300V	R1,R2,R5,R7	R 470Kohm 1/4W
C2	XC 0.1μF/300V	R3	R 100Kohm 1/2W
C3	CC 0.01μF/500V	R4	R 47ohm 1/4W
C4	EC 120μ/400V	R6	R 2Kohm 1/8W
C5	YC 222p/250V	R8	R 0.3ohm 2W
C6	CC 1000pF/100V	R9	R 33Kohm 1/8W
C7	EC 1000μF/25V	R10	R 4.7Kohm 1/8W
C8	EC 470μF/25V	R11	R 470ohm 1/8W
C9	EC 10μF/50V	R12	R 0 ohm 1/8W
C10	CC 222pF/50V	R13	R 4.7Kohm 1/8W
C11	CC 470pF/50V	R14	R 154Kohm 1/8W 1%
D1	LED	R15	R 39Kohm 1/8W 1%
D2	Diode BYV95C	R16	R 100ohm 1/8W
D3	TVS P6KE16A	THER2	Thermistor TTC104
D4	Diode FR103	T1	Transformer (600μH-PQ2620)
F1	FUSE 4A/250V	U1	IC SG5842A/JA
L1	Choke (900μH)	U2	IC PC817
L2	Choke (10mH)	U3	IC TL431
L3	Inductor (2μH)	VZ1	VZ 9G
Q1	Diode 20A/100V		

PACKAGE INFORMATION

8PINS-DIP(D)

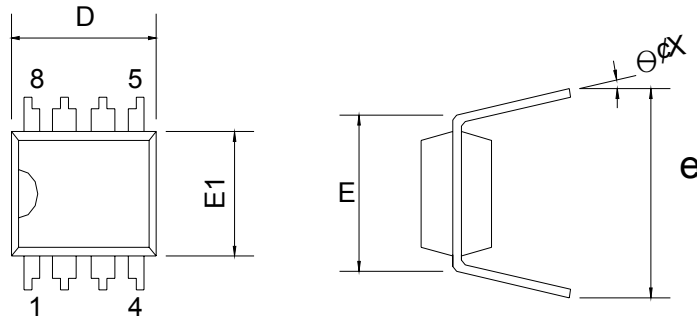

www.DataSheet4U.com

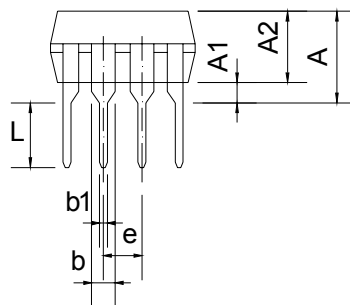

Dimensions

Symbol	Millimeters			Inches		
	Min.	Typ.	Max.	Min.	Typ.	Max.
A			5.334			0.210
A1	0.381			0.015		
A2	3.175	3.302	3.429	0.125	0.130	0.135
b		1.524			0.060	
b1		0.457			0.018	
D	9.017	9.271	10.160	0.355	0.365	0.400
E		7.620			0.300	
E1	6.223	6.350	6.477	0.245	0.250	0.255
e		2.540			0.100	
L	2.921	3.302	3.810	0.115	0.130	0.150
eB	8.509	9.017	9.525	0.335	0.355	0.375
θ°	0°	7°	15°	0°	7°	15°

Highly Integrated Green-Mode PWM Controller

SG5842A/JA

8PINS-SOP(S)

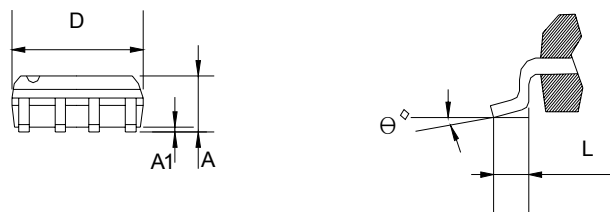
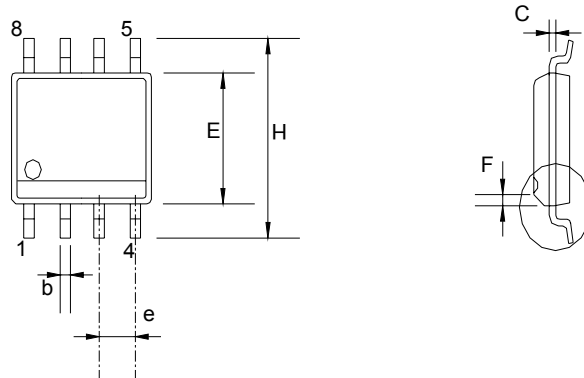

Dimensions

Symbol	Millimeter			Inch		
	Min.	Typ.	Max.	Min.	Typ.	Max.
A	1.346		1.752	0.053		0.069
A1	0.101		0.254	0.004		0.010
b		0.406			0.016	
c		0.203			0.008	
D	4.648		4.978	0.183		0.196
E	3.810		3.987	0.150		0.157
e	1.016	1.270	1.524	0.040	0.050	0.060
F		0.381X45°			0.015X45°	
H	5.791		6.197	0.228		0.244
L	0.406		1.270	0.016		0.050
θ°	0°		8°	0°		8°

Highly Integrated Green-Mode PWM Controller

SG5842A/JA



TRADEMARKS

The following are registered and unregistered trademarks and service marks Fairchild Semiconductor owns or is authorized to use and is not intended to be an exhaustive list of all such trademarks.

- | | | | |
|--------------------------------------|--|--|----------------------------------|
| ACEx [®] | Green FPS [™] | Power247 [®] | SuperSOT [™] -8 |
| Build it Now [™] | Green FPS [™] e-Series [™] | POWEREDGE [®] | SyncFET [™] |
| CorePLUS [™] | GTO [™] | Power-SPM [™] | The Power Franchise [®] |
| CROSSVOLT [™] | i-Lo [™] | PowerTrench [®] | the power franchise |
| CTL [™] | IntelliMAX [™] | Programmable Active Droop [™] | TinyBoost [™] |
| Current Transfer Logic [™] | ISOPLANAR [™] | QFET [®] | TinyBuck [™] |
| EcoSPARK [®] | MegaBuck [™] | QS [™] | TinyLogic [®] |
| f [®] | MICROCOUPLER [™] | QT Optoelectronics [™] | TINYOPTO [™] |
| Fairchild [®] | MicroFET [™] | Quiet Series [™] | TinyPower [™] |
| Fairchild Semiconductor [®] | MicroPak [™] | RapidConfigure [™] | TinyPWM [™] |
| FACT Quiet Series [™] | MillerDrive [™] | SMART START [™] | TinyWire [™] |
| FACT [®] | Motion-SPM [™] | SPM [®] | μSerDes [™] |
| FAST [®] | OPTOLOGIC [®] | STEALTH [™] | UHC [®] |
| FastvCore [™] | OPTOPLANAR [®] | SuperFET [™] | UniFET [™] |
| FPS [™] | U [®] | SuperSOT [™] -3 | VCC [™] |
| FRFET [®] | PDP-SPM [™] | SuperSOT [™] -6 | |
| Global Power Resource SM | Power220 [®] | | |

DISCLAIMER

FAIRCHILD SEMICONDUCTOR RESERVES THE RIGHT TO MAKE CHANGES WITHOUT FURTHER NOTICE TO ANY PRODUCTS HEREIN TO IMPROVE RELIABILITY, FUNCTION, OR DESIGN. FAIRCHILD DOES NOT ASSUME ANY LIABILITY ARISING OUT OF THE APPLICATION OR USE OF ANY PRODUCT OR CIRCUIT DESCRIBED HEREIN; NEITHER DOES IT CONVEY ANY LICENSE UNDER ITS PATENT RIGHTS, NOR THE RIGHTS OF OTHERS. THESE SPECIFICATIONS DO NOT EXPAND THE TERMS OF FAIRCHILD'S WORLDWIDE TERMS AND CONDITIONS, SPECIFICALLY THE WARRANTY THEREIN, WHICH COVERS THESE PRODUCTS.

LIFE SUPPORT POLICY

FAIRCHILD'S PRODUCTS ARE NOT AUTHORIZED FOR USE AS CRITICAL COMPONENTS IN LIFE SUPPORT DEVICES OR SYSTEMS WITHOUT THE EXPRESS WRITTEN APPROVAL OF FAIRCHILD SEMICONDUCTOR CORPORATION.

As used herein:

1. Life support devices or systems are devices or systems which, (a) are intended for surgical implant into the body or (b) support or sustain life, and (c) whose failure to perform when properly used in accordance with instructions for use provided in the labeling, can be reasonably expected to result in a significant injury of the user.
2. A critical component in any component of a life support, device, or system whose failure to perform can be reasonably expected to cause the failure of the life support device or system, or to affect its safety or effectiveness.

PRODUCT STATUS DEFINITIONS

Definition of Terms

Datasheet Identification	Product Status	Definition
Advance Information	Formative or In Design	This datasheet contains the design specifications for product development. Specifications may change in any manner without notice.
Preliminary	First Production	This datasheet contains preliminary data; supplementary data will be published at a later date. Fairchild Semiconductor reserves the right to make changes at any time without notice to improve design.
No Identification Needed	Full Production	This datasheet contains final specifications. Fairchild Semiconductor reserves the right to make changes at any time without notice to improve design.
Obsolete	Not In Production	This datasheet contains specifications on a product that has been discontinued by Fairchild Semiconductor. The datasheet is printed for reference information only.

Rev. 131