

FEATURES OVERVIEW

- Over-voltage protection (OVP) for 3.3V, 5V and 12V
- Over-current protection (OCP) for 3.3V, 5V and 12V
- Under-voltage sense (UVS) for 3.3V, 5V and 12V
- Under-voltage protection (UVP) for 12V
- Open drain output for PGO and FPO pins
- 300mS power good delay
- 75mS delay for 3.3V, 5V and 12V power turn on
- 2.8mS PSON control to FPO turn-off delay
- 38mS / 115mS PSON control De-bounce
- 275uS width noise deglitches
- De-bounce time 125uS for UVP and OCP
- De-bounce time 350uS for UVS
- No lockup during the fast AC power on/off
- Brownout protection function for 12V
- Wide supply voltage range from 4V to 15V
- Over-temperature protection (OTP) function

For supervisor function, it provides the over voltage protection (OVP) monitoring for 3.3V, 5V and 12V; over current (OCP) monitoring for 3.3V, 5V and 12V; under voltage sense (UVS) monitoring for 3.3V, 5V and 12V; under voltage protection (UVP) monitoring for 12V; and over temperature protection (OTP) for SG6513T. When 3.3V, 5V or 12V voltage is decreasing to 2.8V, 4.2V and 9.9V respectively, the under voltage sense (UVS) function will be enabled to reset the PGO signal from high to low. If 12V voltage is further decreasing to 9V, FPO will be set to high to turn off the PWM controller IC. The voltage difference across external current shunt is used for OCP functions. An external resistor can be used to adjust protection threshold. To achieve better immunity for lighting surge glitch and to prevent accidental power shut down during dynamic loading condition, the de-bounce time for UVP/OCP and UVS is 275us/125us ,350us respectively. The deglitch time for OVP is 75uS for better noise immunity.

DESCRIPTION

SG6513 is designed to provide the voltage, current and temperature supervisor function, remote on/off (PSON) function, power good (PGO) indicator function, and fault protection (FPO) function for switching power systems.

The power supply is turned on after 38mS de-bounce time when PSON signal is set from high to low. To turn off power supply, PSON signal is set from low to high and the de-bounce time is 115mS. The PGI circuitry provides a sufficient power-down warning signal for PGO. When PGI input is lower than the internal 1.2V reference voltage, after 250uS de-bounce time, the PGO signal is pulled low.

TYPICAL APPLICATION

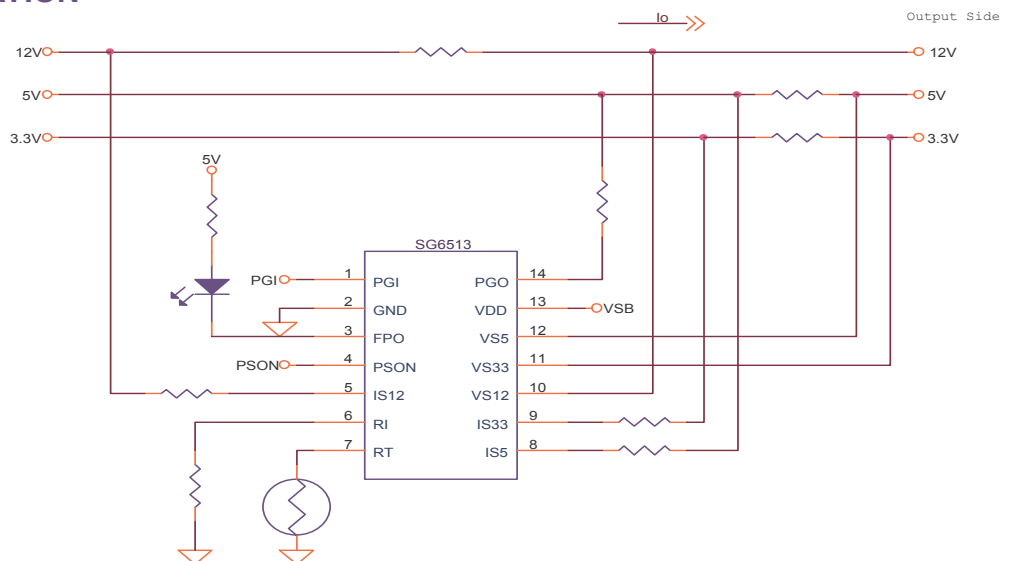

MARKING INFORMATION



T: T = With OTP,
Null = Without OTP
Z: D = DIP, S = SOP(No Logo)
XXXXXXXX: Wafer Lot
YY: Year; WW: Week
V: Assembly Location

PIN CONFIGURATION

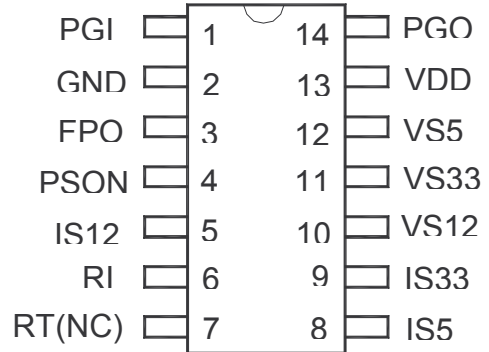

ORDERING INFORMATION

Part Number	Package Type	Function
SG6513D	14 pin DIP Plastic	Without OTP
SG6513S	14 pin SOIC Plastic	Without OTP
SG6513TD	14 pin DIP Plastic	With OTP
SG6513TS	14 pin SOIC Plastic	With OTP

PIN DESCRIPTIONS

Pin No.	Pin Name	Type	Description
1	PGI	Analog input	Power good input. For ATX SMPS, it detects AC line voltage through the main transformer.
2	GND	Supply	Ground.
3	FPO	Logic output	Fault protection output. Output signal to control the primary PWM IC through a opto-coupler. When FPO is low, the main SMPS is operational.
4	PSON	Logic input	Remote On/Off logic input from CPU or main-board. The power supply will be turned on/off after 38mS / 115mS delay.
5	IS12	Analog input	12V over current protection sense input. Regarding typical application, this pin is connected to the positive end of a current shunt through one resistor. When the voltage on IS12 is higher than that of VS12 by 5mV, OCP will be enabled. One current sink, 8 x Iref, is used to determine the voltage drop between the positive end of the current shunt and VS12. Adjusting the value of the external resistor can adjust the threshold for OCP accordingly. The operation for IS5 or IS33 is the same.
6	RI	Analog input	Reference setting. One external resistor Ri connected between RI and GND pin will determine a reference current, Iref = 1.15/Ri, for OTP and OCP programming.
7	RT(for SG6513T) NC(for SG6513)	Analog input	Over-temperature protection. Only valid for SG6513T. An NTC thermistor is connected from RT pin to GND. At high temperature, the impedance of the NTC will decrease and hence the voltage on RT will decrease. When the voltage on RT pin is lower than 0.95V limit, the over-temperature protection will be enabled. The internal pull high current source is equal to 5 x Iref.
8	IS5	Analog input	5V over current protection sense input.
9	IS33	Analog input	3.3V over current protection sense input.
10	VS12	Analog input	12V over/under-voltage control sense input.
11	VS33	Analog input	3.3V over/under-voltage control sense input.

PC Power Supply Supervisors**SG6513/T**

12	VS5	Analog input	5V over/under-voltage control sense input.
13	V _{DD}	Supply	Supply voltage. 4V ~ 15V. For ATX SMPS, it is connected to 5V-standby and 12V through diodes respectively.
14	PGO	Logic output	Power good logic output, 0 or 1(open-drain). Power good=1 means that the power supply is good for operation. The power good delay is 300mS.

BLOCK DIAGRAM

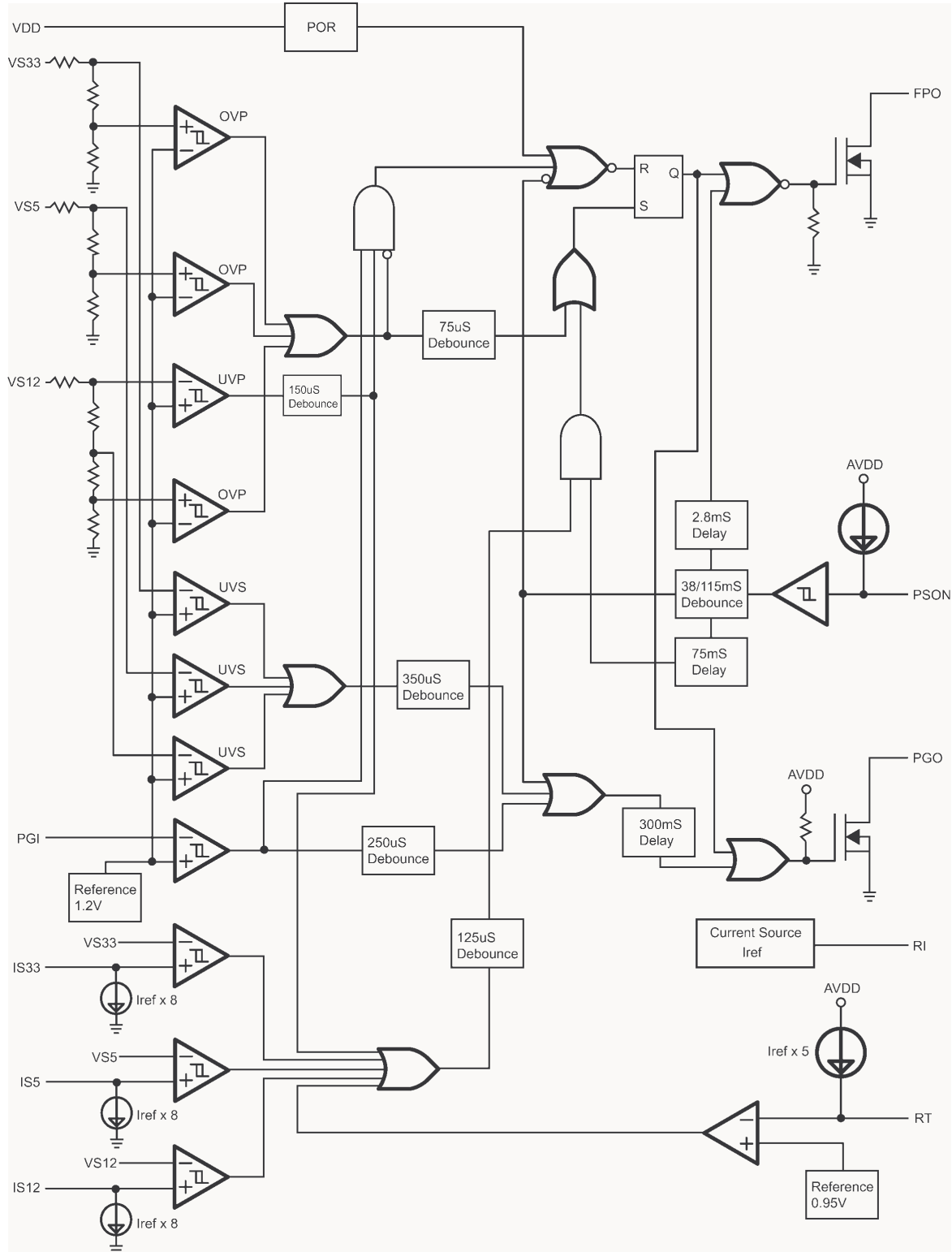

FUNCTION TABLE

PGI	PSON	UV Sense	UV Protection 12V & OC Protection	OV Protection	FPO	PGO
PGI<1.2V	L	No	No	No	L	L
PGI<1.2V	L	Yes	No	No	L	L
PGI<1.2V	L	No	No	Yes	H	L
PGI<1.2V	L	No	Yes	No	L	L
PGI<1.2V	L	Yes	No	Yes	H	L
PGI<1.2V	L	Yes	Yes	No	L	L
PGI<1.2V	L	No	Yes	Yes	H	L
PGI<1.2V	L	Yes	Yes	Yes	H	L
PGI>1.2V	L	No	No	No	L	H
PGI>1.2V	L	Yes	No	No	L	L
PGI>1.2V	L	No	No	Yes	H	L
PGI>1.2V	L	No	Yes	No	H	L
PGI>1.2V	L	Yes	No	Yes	H	L
PGI>1.2V	L	Yes	Yes	No	H	L
PGI>1.2V	L	No	Yes	Yes	H	L
PGI>1.2V	L	Yes	Yes	Yes	H	L
X	H	X	X	X	H	L

x = don't care

FPO = L means: fault IS NOT latched

FPO = H means: fault IS latched

PGO = L means: fault

PGO = H means: No fault

TIMING DIAGRAM

Pson On/Off and 3.3V, 5V UVS/OVP Function

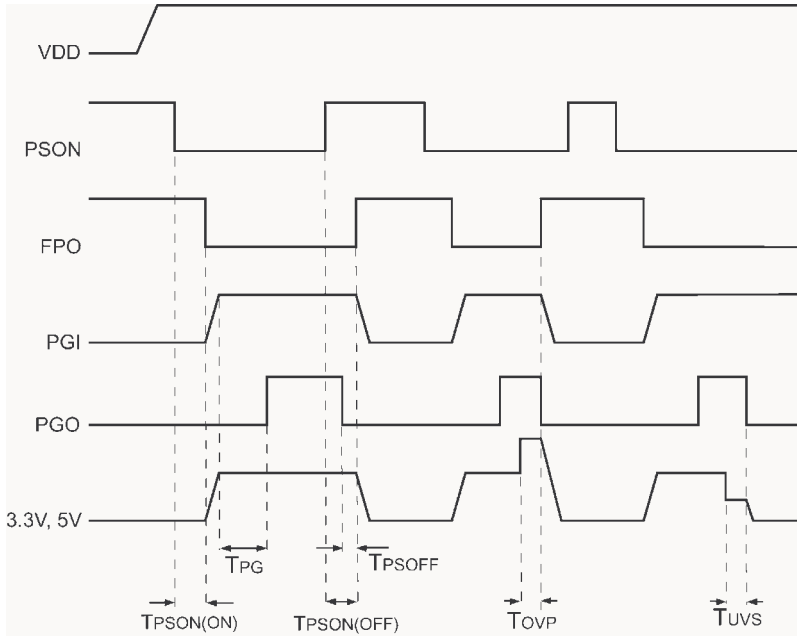

12V OVP/UVS/UVF and OCP Function

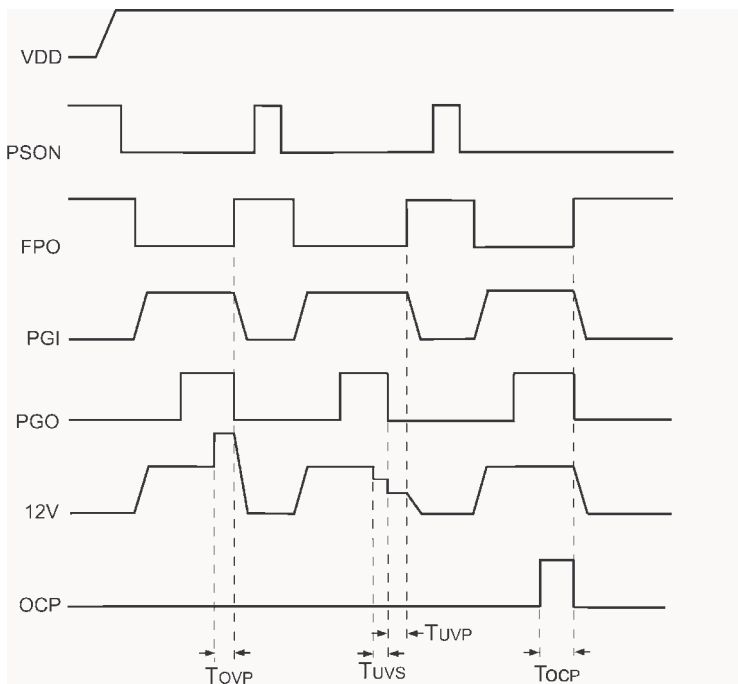

ABSOLUTE MAXIMUM RATINGS

Symbol	Parameter	Min.	Max.	Unit
V _{DD}	DC Supply Voltage	-0.3	16	V
V _I	Input Voltage	PERSON, VS33, VS5, PGI	8	V
V _{OUT}	Output Voltage	FPO	16	V
		PGO	8	
P _D	Power Dissipation		400	mW
T _A	Operating Free Air Temperature Range	-40	85	°C
T _{STG}	Storage Temperature Range	-55	150	°C
	Soldering Temperature		260	°C
	ESD Capability, HBM model		5	KV

Note: Stresses above those listed may cause permanent damage to the device.

RECOMMENDED OPERATING CONDITIONS

Symbol	Parameter	Min.	Max.	Unit	
V _{DD}	DC Supply Voltage	4	15	V	
V _I	Input Voltage	PERSON, VS33, VS5, IS33, IS5, PGI	7	V	
	Input Voltage	VS12, IS12	15		
V _{OUT}	Output Voltage	FPO	15	V	
		PGO	7		
I _{OSINK}	Output Sink Current	FPO	20	mA	
		PGO	10		
T _R	Supply Voltage Rising Time	See Note	1	mS	
I _{RI}	Output Current RI		12.5	62.5	uA

Note: VDD rising and falling slew rate must be less than 14V/mS.

ELECTRICAL CHARACTERISTICS (VDD=12V, TA=25°C)
Over-voltage and Over-current Protection

Symbol	Parameter	Test Conditions	Min.	Typ.	Max.	Unit
V _{OVP}	Over-voltage Protection VS33		3.9	4.1	4.3	V
	Over-voltage Protection VS5		5.7	6.1	6.5	
	Over-voltage Protection VS12		13.2	13.8	14.4	
I _{REF}	Ratio of current sense sink current to current sense setting pin (RI) source current	RI = 30 KΩ, 0.1% Resistor	7.6	8	8.4	
V _{OFFSET}	OCP comparator input offset voltage		-5		5	mV
I _{LKG}	Leakage Current (FPO)	V(FPO) = 5V			5	uA
V _{OL}	Low Level Output Voltage (FPO)	Isink 20mA			0.7	V
T _{OVP}	Timing OVP to Protection		33	75	110	uS
T _{OCP}	Timing OCP to Protection		75	125	175	uS
V _{RI}	Current Source Reference Voltage		1.1	1.15	1.2	V

Under-voltage and PGI, PGO

Symbol	Parameter	Test Conditions	Min.	Typ.	Max.	Unit
V _{PGI}	Input Threshold Voltage PGI		1.15	1.2	1.25	V
V _{UVS}	Under-voltage Sense VS33		2.6	2.8	3.0	V
	Under-voltage Sense VS5		4.0	4.2	4.4	
	Under-voltage Sense VS12		9.4	9.9	10.4	
V _{UVP}	Under-voltage Protection VS12		8.5	9	9.5	V
	Under-voltage Enable Delay Time		49	75	114	mS
T _{UVS}	Timing UVS to Sense (PG)	VS33, VS5, VS12	200	350	500	uS
T _{UVP}	Timing UVP to Protection (FPO)	VS12	175	275	375	uS
I _{LKG}	Leakage Current (PGO)	PGO = 5V			5	uA
V _{OL}	Low Level Output Voltage (PGO)	VDD = 12V Isink 10mA			0.7	V
T _{PG}	Timing PG Delay	PGI to PGO	200	300	450	mS
	Noise Deglitch Time	PGI to PGO	150	250	350	uS

PSON Control

Symbol	Parameter	Test Conditions	Min.	Typ.	Max.	Unit
I _{PSON}	Input Pull-up Current	PSON = 0V		120		uA
V _{IH}	High-level Input Voltage		2.0			V
V _{IL}	Low-level Input Voltage				0.8	V
T _{PSON}	Timing PSON to On/Off	On	24	38	57	mS
		Off	70	115	200	
T _{PSOFF}	Timing PG Low to Power Off		1.6	2.8	4.5	mS

Over Temperature Protection (only for SG6513T)

Symbol	Parameter	Test Conditions	Min.	Typ.	Max.	Unit
V _{OTP}	Over Temperature Threshold Voltage	VDD = 12V	0.9	0.95	1.0	V
I _{OTP}	Ratio of RT source current to current sense setting pin (RI) source current	RI = 30 KΩ, 0.1% Resistor	4.75	5	5.25	

Total Device

Symbol	Parameter	Test Conditions	Min.	Typ.	Max.	Unit
I _{DD}	Supply Current	PSON = 5V , VDD = 5V		1.0	1.8	mA
V _{ST}	VDD Start Threshold Voltage				4.0	V
V _{MIN}	VDD Min. Operation Voltage After Start-up		3.65			V

PACKAGE INFORMATION

14 PINS – PLASTIC DIP (D)

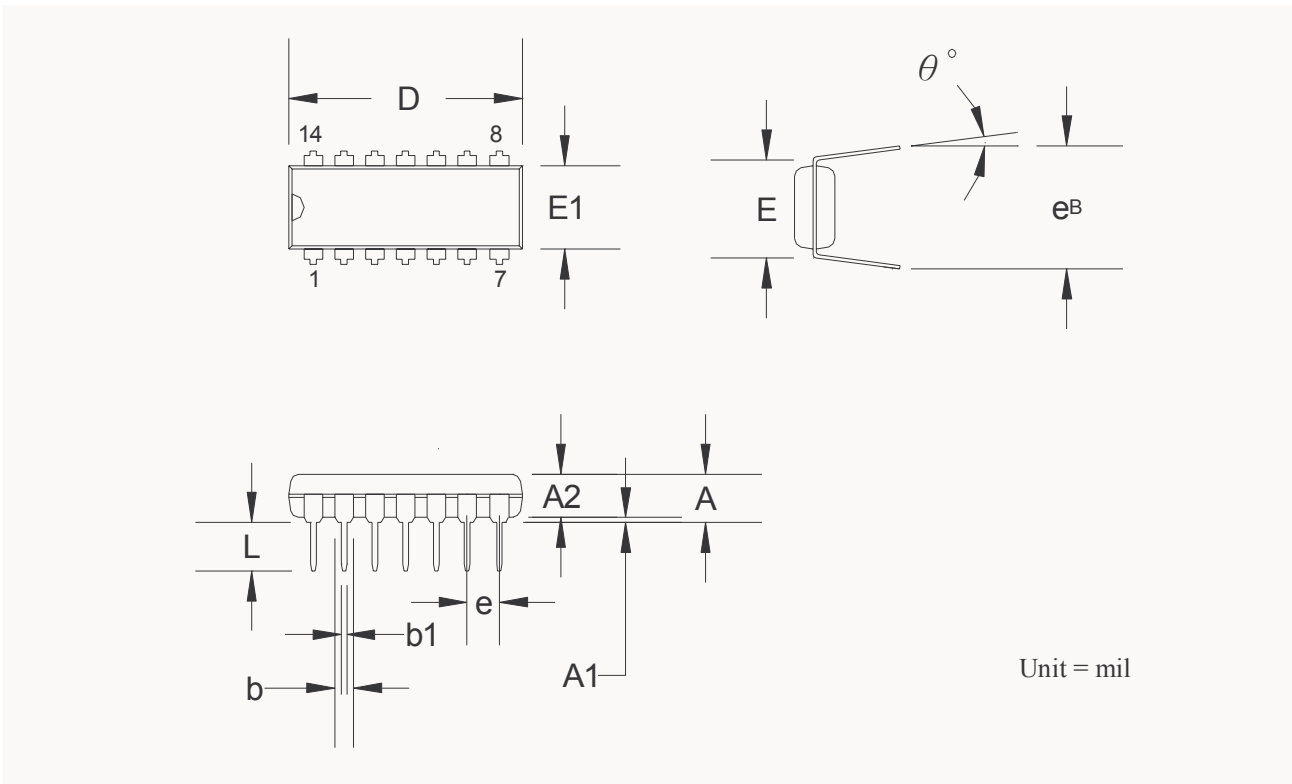

Dimension:

Symbol	Millimeter			Inch		
	Min.	Typ.	Max.	Min.	Typ.	Max.
A			5.334			0.210
A1	0.381			0.015		
A2	3.175	3.302	3.429	0.125	0.130	0.135
b		1.524			0.060	
b1		0.457			0.018	
D	18.669	19.050	19.685	0.735	0.750	0.775
E		7.620			0.300	
E1	6.223	6.350	6.477	0.245	0.250	0.255
e		2.540			0.100	
L	2.921	3.302	3.810	0.115	0.130	0.150
e_B	8.509	9.017	9.525	0.335	0.355	0.375
θ°	0°	7°	15°	0°	7°	15°

14 PINS – PLASTIC SO (S)

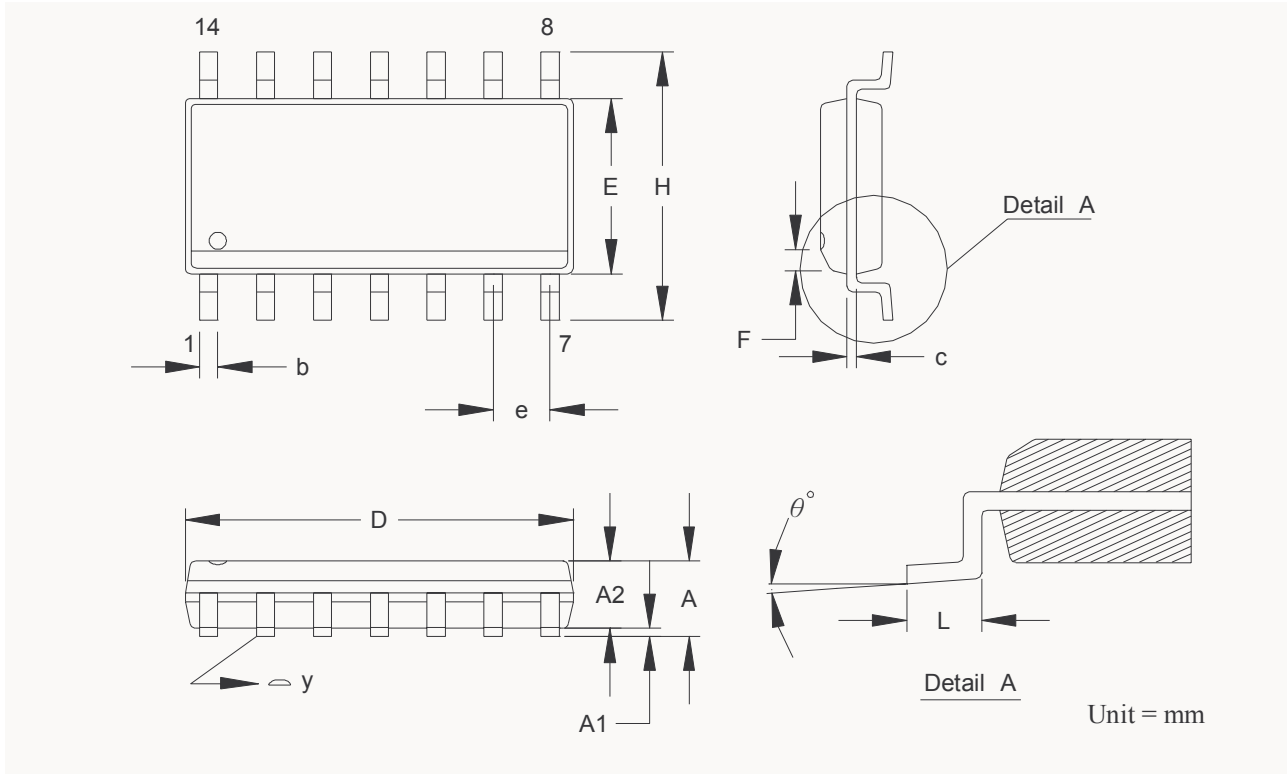

Dimension:

Symbol	Millimeter			Inch		
	Min.	Typ.	Max.	Min.	Typ.	Max.
A	1.473	1.626	1.727	0.058	0.064	0.068
A1	0.101		0.254	0.004		0.010
A2	1.371		1.473	0.054		0.058
b	0.330	0.406	0.508	0.013	0.016	0.020
c	0.190	0.203	0.249	0.0075	0.008	0.0098
D	8.534	8.661	8.484	0.336	0.341	0.344
E	3.810	3.912	3.988	0.150	0.154	0.157
e		1.270			0.050	
H	5.791	5.994	5.690	0.228	0.236	0.244
L	0.381	0.635	1.270	0.015	0.025	0.050
F		0.381X45°			0.015X45°	
y			0.101			0.004
θ°	0°		8°	0°		8°

DISCLAIMERS

LIFE SUPPORT

System General's products are not designed to be used as components in devices intended to support or sustain human life. Use of System General's products in components intended for surgical implant into the body, or other applications in which failure of the System General's products could create a situation where personal death or injury may occur, is not authorized without the express written approval of System General's Chief Executive Officer. System General will not be held liable for any damages or claims resulting from the use of its products in medical applications.

MILITARY

System General's products are not designed for use in military applications. Use of System General's products in military applications is not authorized without the express written approval of System General's Chief Executive Officer. System General will not be held liable for any damages or claims resulting from the use of its products in military applications.

RIGHT TO MAKE CHANGES

System General reserves the right to change this document and/or this product without notice. Customers are advised to consult their System General sales representative before ordering.