



SG6849

Low-Power, Green-Mode PWM Flyback Power Controller without Secondary Feedback

Features

- Linearly Decreasing PWM Frequency
- Green-Mode Under Light-Load and Zero-Load Conditions
- Constant Voltage (CV) and Constant Current (CC)
- No Secondary Feedback
- Low Startup Current: 5 μ A
- Low Operating Current: 3.6mA
- Leading-Edge Blanking (LEB)
- Constant Power Limit
- Universal AC Input Range
- Synchronized Slope Compensation
- 150°C OTP Sensor with Hysteresis
- V_{DD} Over-Voltage Clamping
- Cycle-by-Cycle Current Limiting
- Under-Voltage Lockout (UVLO)
- Fixed PWM Frequency: 65kHz
- Gate Output Maximum Voltage Clamped at 16.7V
- Small SSOT-6 Package

Applications

Low-power, flyback power converters, such as:

- Battery chargers for cellular phones, cordless phones, PDAs, digital cameras, and power tools
- Power adapters for ink jet printers, video game consoles, and portable audio players
- Open-frame SMPS for TV/DVD standby and other auxiliary supplies, home appliances, consumer electronics, and PC 5V standby-power
- Replacements for linear transformers and RCC SMPS

Description

This highly integrated PWM controller provides several features to enhance the performance of low-power flyback converters. To minimize standby power consumption, the proprietary green-mode function provides off-time modulation to linearly decrease the switching frequency under light-load and zero-load conditions. This green-mode function enables the power supply to meet international power conservation requirements.

The supply voltage V_{DD} is also used for feedback compensation to regulate the output voltage without requiring a conventional TL431 and a photo-coupler. An advantage of the SG6849 is a typical startup current of only 5 μ A, while the typical operating current can be as low as 3.6mA. A large startup resistance can be used to achieve even higher power conversion efficiency.

Built-in synchronized slope compensation maintains the stability of peak current-mode control. Proprietary internal compensation ensures constant output power limiting over a universal range of AC input voltages, from 90V_{AC} to 264V_{AC}.

The SG6849 provides many protection functions. Pulse-by-pulse current limiting ensures a constant output current, even if a short circuit occurs. The internal protection circuit disables PWM output if V_{DD} exceeds 22.7V. The gate output is clamped at 16.7V to protect the power MOS from over-voltage damage. The built-in over-temperature protection (OTP) function shuts down the controller at 150°C with a 20°C hysteresis.

The SG6849 is designed to provide a low-cost total solution for flyback converters. It is available in a small footprint, 6-pin, SSOT-6 package.

Related Resources

- [AN-6849 - Low Cost, Green-Mode PWM Controller for Flyback Converters](#)

Ordering Information

Part Number	Operating Temperature Range	Package	Eco Status	Packing Method
SG684965TZ	-40°C to +105°C	Small SOT-26 Package	RoHS	Tape & reel
SG684965DZ	-40°C to +105°C	8-pin Dual in-line Package (DIP)	RoHS	Tube
SG684965DY	-40°C to +105°C	8-pin Dual in-line Package (DIP)	Green	Tube

Application Diagram

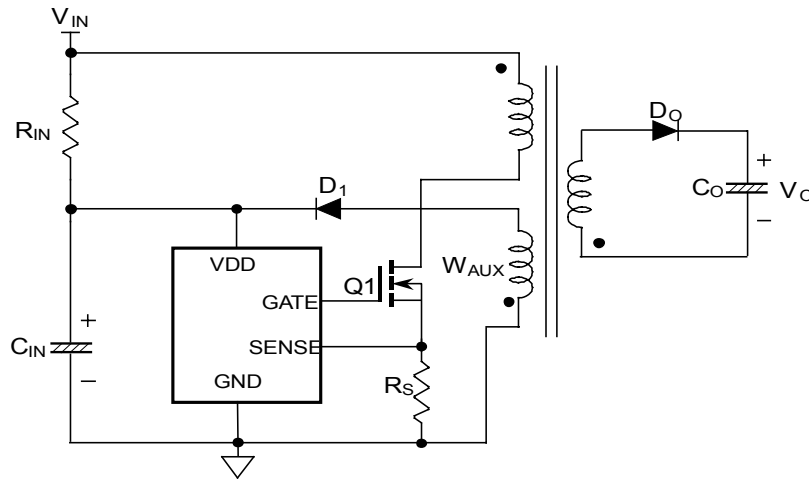

Figure 1. Typical Application

Internal Block Diagram

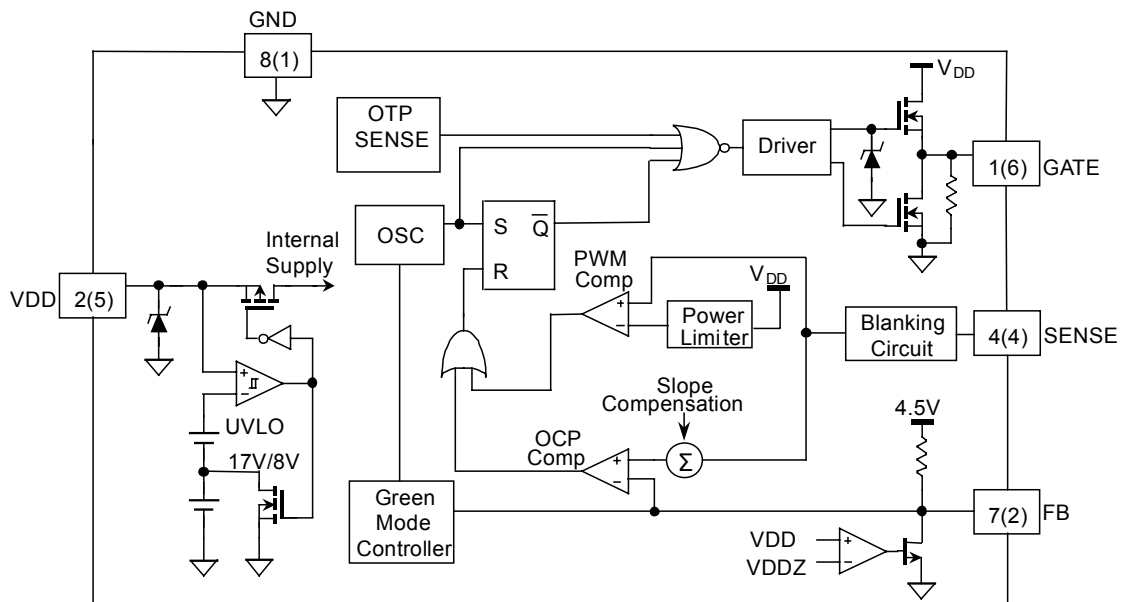
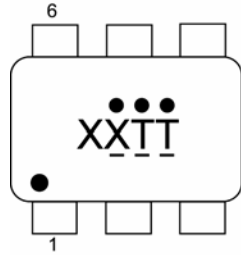

Figure 2. Functional Block Diagram

Marking Information



XX: BB=SG6849-65T
 TT : Die Run Code
 . . . : Year Code
 - - - : Week Code

***Marking for SG684965TZ (Pb-free)**

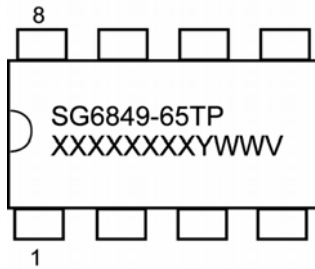

T: D=DIP
 P: Z= Lead free + RoHS Compatible
 Null=Regular Package
 XXXXXXXX: Wafer Lot
 Y: Year
 WW: Week
 V: Assembly location

***Marking for SG684965DZ (Pb-free)**

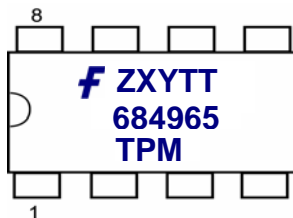

F- Fairchild Logo
 Z- Plant Code
 X- 1 Digit Year Code
 Y- 1 Digit Week Code
 TT: 2 Digits Die Run Code
 T: Package Type (D=DIP)
 P: Z: Pb-free, Y: Green package
 M: Manufacture Flow Code

***Marking for SG684965DY (Green Compound)**

Figure 3. Top Mark

Pin Configurations

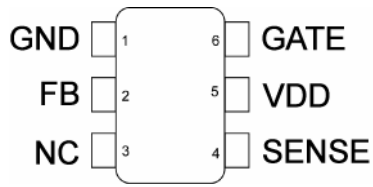

Figure 4. SSOT-6 Pin Configuration

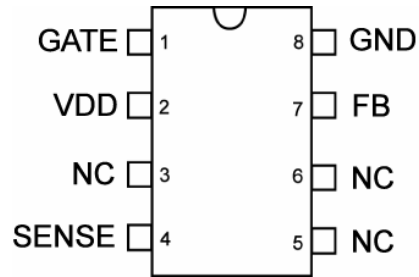

Figure 5. DIP-8 Pin Configuration

Pin Definitions

DIP Pin #	SSOT Pin #	Name	Description
1	6	GATE	The totem-pole output driver for driving the power MOSFET.
2	5	VDD	Power supply.
3		NC	No connection.
4	4	SENSE	Current sense. It senses the voltage across a sensed resistor. To provide over-current protection, PWM output is disabled if the voltage exceeds an internal threshold. This pin provides current information for current-mode control.
5	3	NC	No connection.
6		NC	No connection.
7	2	FB	Feedback. The FB pin provides feedback information to the internal PWM comparator. This feedback is used to control the duty cycle. When no feedback is provided, this pin is left open.
8	1	GND	Ground.

Absolute Maximum Ratings

Stresses exceeding the absolute maximum ratings may damage the device. The device may not function or be operable above the recommended operating conditions and stressing the parts to these levels is not recommended. In addition, extended exposure to stresses above the recommended operating conditions may affect device reliability. The absolute maximum ratings are stress ratings only.

Symbol	Parameter	Min.	Max.	Unit
V _{VDD}	DC Supply Voltage ^(1, 2)		25	V
V _{FB}	Input Voltage to FB Pin	-0.3	7.0	V
V _{SENSE}	Input Voltage to Sense Pin	-0.3	7.0	V
T _J	Operating Junction Temperature	-40	+125	°C
Θ _{JA}	Thermal Resistance (Junction-to-Air)	SSOT	263.3	°C/W
		DIP	135.7	°C/W
T _{STG}	Storage Temperature Range	-55	+150	°C
T _L	Lead Temperature (Wave Soldering or IR, 10 Seconds)		+260	°C
ESD	Human Body Model, JEDEC:JESD22-A114		3.0	kV
	Machine Model, JEDEC:JESD22-C101		300	V

Notes:

1. All voltage values, except differential voltages, are given with respect to GND pin.
2. Stresses beyond those listed under "absolute maximum ratings" may cause permanent damage to the device.

Electrical Characteristics

Unless otherwise noted, $V_{DD}=15V$ and $T_A=25^\circ C$.

Symbol	Parameter	Conditions	Min.	Typ.	Max.	Units
V_{DD} Section						
V _{DD-ON}	Turn-on Threshold Voltage		16	17	18	V
V _{DD-OFF}	Turn-off Threshold Voltage		7.5	8.0	8.5	V
I _{DD-ST}	Startup Current	V _{DD} =15V		5	20	μA
I _{DD-OP}	Operating Supply Current	V _{DD} =15V, C _L =1nF		3.6	4.6	mA
V _{DD-CLAMP}	Zener Diode Breakdown Voltage	I _{DD} =10mA		28	30	V
V _{DD-TH-G}	V _{DD} -Low Threshold Voltage for Exiting Green-Mode OFF		V _{DD-OFF} +1.0	V _{DD-OFF} +1.5	V _{DD-OFF} +2.0	V
Feedback Input Section						
I _{FB-ZDC}	Zero Duty Cycle FB Input Current			1.15	1.40	mA
V _{FB-OPEN}	Open-Loop Voltage		4.5			V
Z _{FB}	Input Impedance	I _{FB} =0.1mA to 0.2mA		2.4		kΩ
V _{DD-FB}	V _{DD} Feedback Threshold Voltage*	FB is Open	20.0	22.7	25.0	V
		I _{FB} =0.4mA	18	20	22	V
Current-Sense Section						
t _{PD}	Delay to Output			100		ns
V _{STHVA}	Valley Threshold Voltage for Current Limit	V _{DD} =20V	0.84	0.89	0.94	V
		V _{DD} =15V	0.72	0.77	0.82	V
		V _{DD} =10V	0.58	0.63	0.68	V
t _{LEB}	Leading-Edge Blanking Time			310		ns

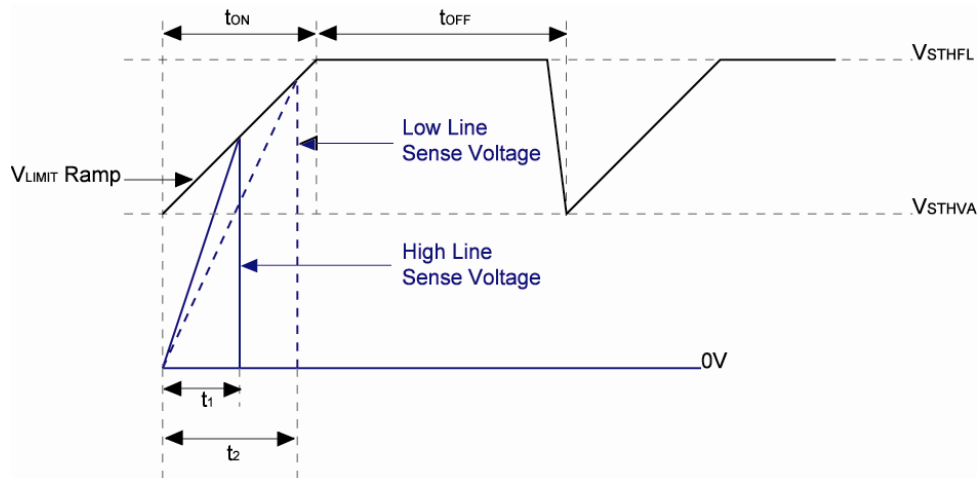

Figure 6. Saw Limit

Electrical Characteristics (Continued)Unless otherwise noted, $V_{DD}=15V$ and $T_A=25^{\circ}C$.

Symbol	Parameter	Conditions	Min.	Typ.	Max.	Units
Oscillator Section						
f_{OSC}	Frequency		60	65	70	kHz
f_{OSC-G}	Green-Mode Frequency		20	25	30	kHz
I_{FB-G}	Green-Mode Ending FB Current		0.90	1.15	1.40	mA
f_{DV}	Frequency Variation vs. V_{DD} Deviation	$V_{DD}=10$ to $20V$			2.00	%
Output Section						
DCY_{MAX}	Maximum Duty Cycle		70	75	80	%
V_{GATE-L}	Output Voltage Low	$V_{DD}=15V, I_o=10mA$			1.5	V
V_{GATE-H}	Output Voltage High	$V_{DD}=15V, I_o=10mA$	8			V
t_r	Rising Time	$V_{DD}=15V, C_L=1nF$		200		ns
t_f	Falling Time	$V_{DD}=15V, C_L=1nF$		80		ns
$V_{GATE-CLAMP}$	Output Clamp Voltage	$V_{DD}=20V$		16.7	18.0	V
Over-Temperature Protection (OTP)						
T_{OTP}	Protection Junction Temperature			+150		$^{\circ}C$
$T_{OTP-RESTART}$	Restart Junction Temperature			+130		$^{\circ}C$

Typical Performance Characteristics

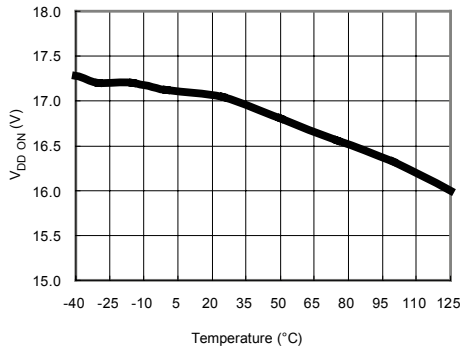

Figure 7. Turn-on Threshold Voltage (V_{DD-ON}) vs. Temperature

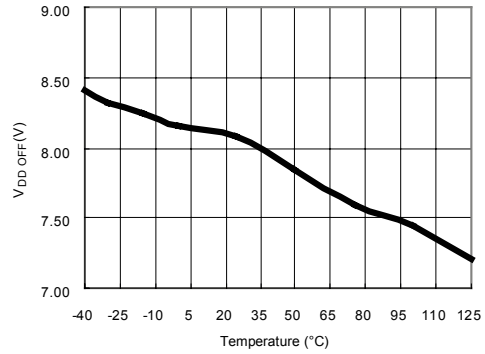

Figure 8. Turn-off Threshold Voltage (V_{DD-OFF}) vs. Temperature

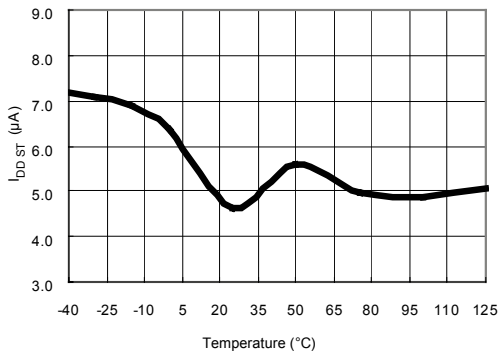

Figure 9. Startup Current (I_{DD-ST}) vs. Temperature

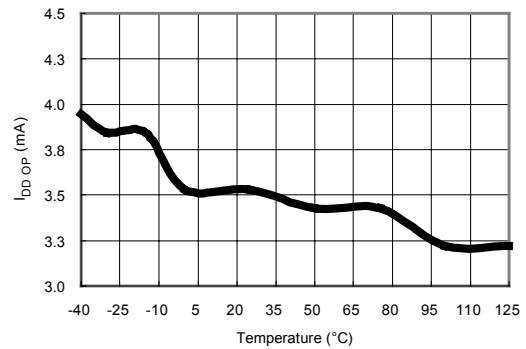

Figure 10. Center Frequency (f_{OSC}) vs. Temperature

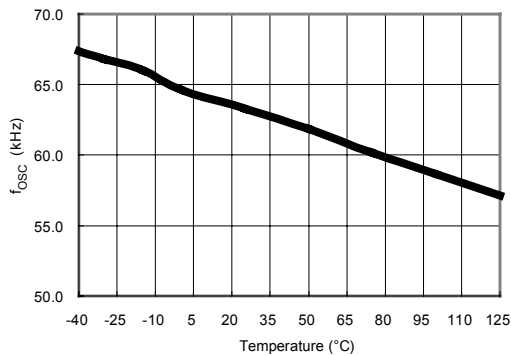

Figure 11. Center Frequency (f_{OSC}) vs. Temperature

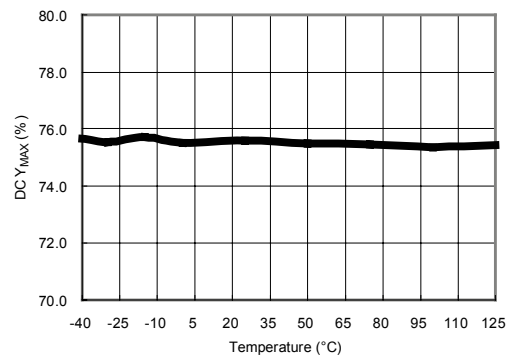

Figure 12. Maximum Duty Cycle (DCY_{MAX}) vs. Temperature

Typical Performance Characteristics (Continued)

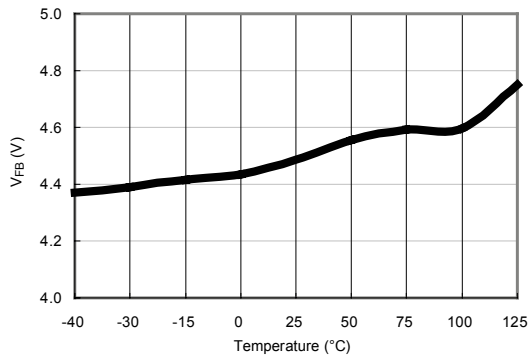

Figure 13. FB Open-Loop Voltage (V_{FB}) vs. Temperature

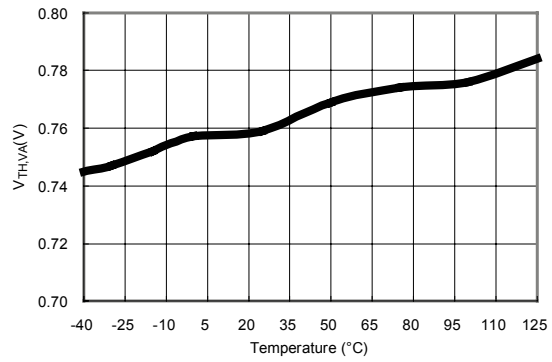

Figure 14. Valley Threshold Voltage (V_{STHVA}) vs. Temperature

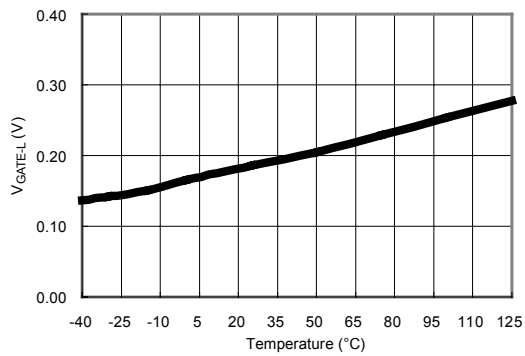

Figure 15. Output Voltage Low (V_{GATE-L}) vs. Temperature

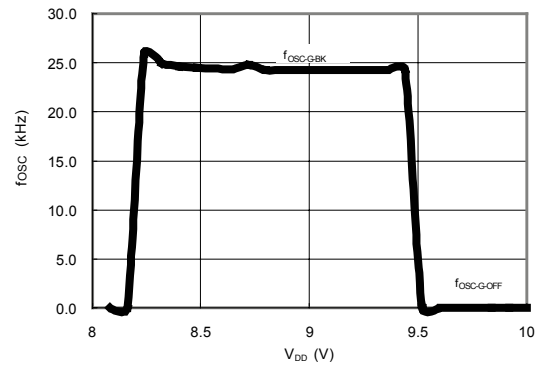

Figure 16. Green-Mode Burst Back and Green-Mode Off Frequency vs. V_{DD}

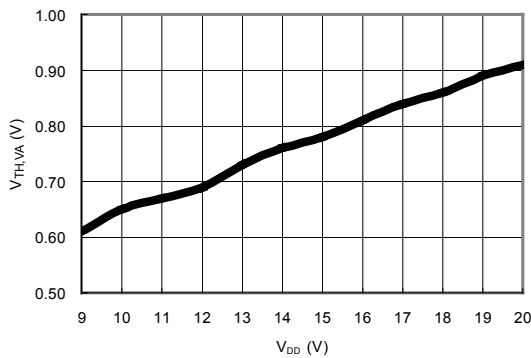

Figure 17. Valley Threshold Voltage (V_{STHVA}) vs. V_{DD}

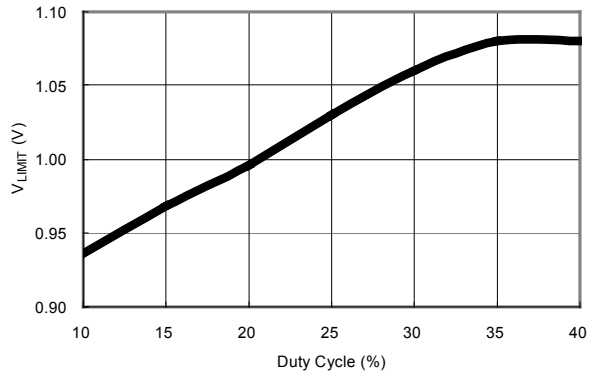

Figure 18. V_{LIMIT} Ramp vs. Duty Cycle

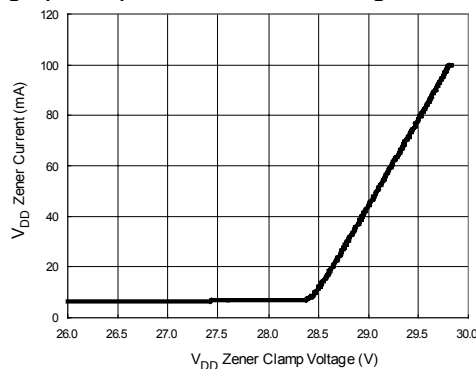

Figure 19. V_{DD} Zener Current vs. Zener Clamp Voltage

Operation Description

SG6849 devices integrate many useful functions for low-power switch-mode power supplies. The following descriptions highlight the key features of the SG6849.

Startup Current

The required startup current is only 5 μ A. This allows a high-resistance, low-wattage startup resistor to be used to supply the controller's startup power. A 1.5M Ω /0.25W startup resistor can be used over a wide input range (90V_{AC}-264V_{AC}) with very little power loss.

Operating Current

The operating current is normally 3.6mA. The low operating current results in higher efficiency and reduces the required V_{DD} hold-up capacitance. A 10 μ F/25V V_{DD} hold-up capacitor can be used over a wide input range (90V_{AC} -264V_{AC}) with little power loss.

Green-Mode Operation

The proprietary green-mode function provides off-time modulation to linearly decrease the switching frequency under light-load and zero-load conditions. The on-time is limited to provide better protection against brownouts and other abnormal conditions.

This green-mode function dramatically reduces power consumption under light-load and zero-load conditions. Power supplies using SG6849 can meet international restrictions regarding standby power-consumption.

Constant Voltage (CV) and Constant Current (CC) without Feedback

The SG6849 tightly regulates the output voltage and provide over-current protection without requiring secondary-side feedback signals. For improved CV and CC accuracy, the transformer leakage inductance should be reduced as much as possible.

Over-Temperature Protection (OTP)

The SG6849 has a built-in temperature sensing circuit to shut down PWM output once the junction temperature exceeds 150°C. While PWM output is shut down, the V_{DD} voltage gradually drops to the UVLO voltage. Some of the SG6849's internal circuits are shut down and V_{DD} gradually starts increasing again. When V_{DD} reaches 17V, all the internal circuits, including the temperature sensing circuit, starts operating normally. If the junction temperature is still higher than 150°C, the PWM controller is shut down immediately. This situation continues until the temperature drops below 130°C. The PWM output then turns back on. The temperature hysteresis window for the OTP circuit is 20°C.

V_{DD} Over-Voltage Clamping

V_{DD} over-voltage clamping is built in to prevent damage from over-voltage conditions. When V_{DD} exceeds 22.7V, PWM output is shut down. Over-voltage conditions may be caused by an open photo-coupler loop or a short circuit in the output.

Oscillator Operation

The oscillation frequency is fixed at 65kHz.

Leading-Edge Blanking (LEB)

Each time the power MOSFET is switched on, a turn-on spike occurs at the sense resistor. To avoid premature termination of the switching pulse, a 310ns leading-edge blanking time is built in. Conventional RC filtering is not necessary. During this blanking period, the current-limit comparator is disabled and it cannot switch off the gate drive.

Constant Output Power Limit

When the SENSE voltage across the sense resistor R_S reaches the threshold voltage (around 1.0V), the output GATE drive is turned off following a small propagation delay t_{PD}. This propagation delay introduces an additional current proportional to t_{PD}•V_{IN}/L_P. The propagation delay is nearly constant regardless of the input line voltage V_{IN}. Higher input line voltages result in larger additional currents. Under high input-line voltages, the output power limit is higher than under low input-line voltages.

Over a wide range of AC input voltages, the variation can be significant. To compensate for this, the threshold voltage is adjusted by adding a positive ramp (V_{LIMIT-ramp}). This ramp signal varies from 0.77V to 1.05V for SG6849 and it flattens out at 1.05V. A smaller threshold voltage forces the output GATE drive to terminate earlier, reducing total PWM turn-on time and making the output power equal to that of the low line input. This proprietary internal compensation feature ensures a constant output power limit over a wide range of AC input voltages (90V_{AC}-264V_{AC}).

Under-Voltage Lockout (UVLO)

The turn-on / turn-off thresholds of the SG6849 are fixed internally at 17V/8V. To enable the SG6849 during startup, the hold-up capacitor must first be charged to 17V through the startup resistor.

The hold-up capacitor continues to supply V_{DD} before energy can be delivered from the auxiliary winding of the main transformer. V_{DD} must not drop below 8V during this startup process. This UVLO hysteresis window ensures that the hold-up capacitor can adequately supply V_{DD} during startup.

Gate Output

The SG6849 BiCMOS output stage is a fast totem-pole gate driver. Cross-conduction is avoided to minimize heat dissipation, increase efficiency, and enhance reliability. The output driver is clamped by an internal 16.7V Zener diode to protect the power MOSFET transistors against harmful over-voltage gate signals.

Slope Compensation

The sensed voltage across the current sense resistor is used for current-mode control and pulse-by-pulse current limiting. The built-in slope compensation function improves power supply stability. Furthermore, it prevents sub-harmonic oscillations that normally would occur because of peak current mode control. A positively sloped, synchronized ramp is activated by the SG6849 with every switching cycle. The slope of the ramp is:

$$\frac{0.36 \times \text{Duty}}{\text{Duty}(\text{max.})} \quad (1)$$

Noise Immunity

Noise from the current sense or the control signal may cause significant pulse width jitter, particularly in continuous-conduction mode. Slope compensation helps alleviate this problem. Good placement and layout practices should be followed. Avoid long PCB traces and component leads. Compensation and filter components should be located near the SG6849. Increasing the power-MOS gate resistance is advised.

Applications Information

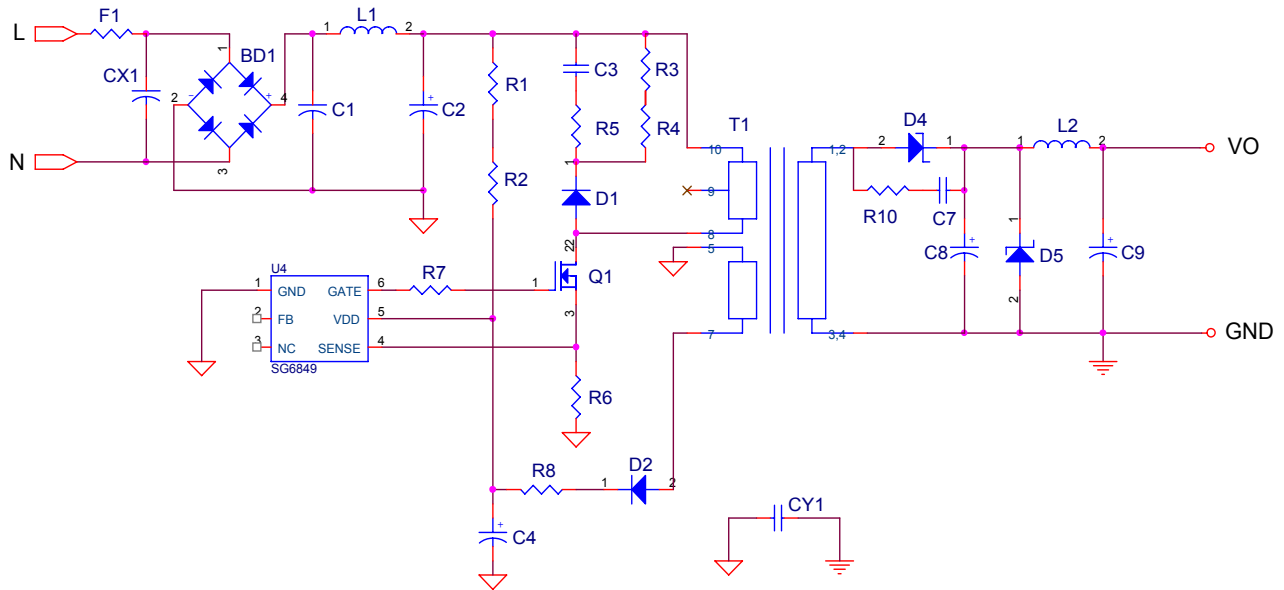

Figure 20. Reference Circuit (without Secondary-Side Feedback)

BOM

Reference	Component	Reference	Component
BD1	BD DI106 1A/600V	F1	R 1 Ω /0.5W
CX1 (Option)	YC 472pF/400V (Y1)	L1	Inductor 20mH 6*8mm
CY1 (Option)	YC 102pF/400V (Y1)	L2	Inductor 10 μ H 6mm
C1	CC 0.01 μ F/500V	Q1	MOSFET 1A/600V
C2	EC 10 μ F/400V 105 $^{\circ}$ C	R1,R2	R 750k Ω /1206
C3	CC 1000pF/500V	R3,R4	R 47k Ω /1206
C4	EC 10 μ F/50V	R5	R 47 Ω /1206
C7 (Option)	CC 102pF/100V 1206	R6	R 4.7 Ω /0.5W
C8	EC 470 μ F/10V 105 $^{\circ}$ C	R7	R 100 Ω /0805
C9	EC 220 μ F/10V 105 $^{\circ}$ C	R8	R 10 Ω /1206
D1	Diode FRI07	R10(Optional)	R 10 Ω /1206
D2	Diode FR102	T1	Transformer EE-16
D4	Diode SB360	U4	IC SG6849 (Green PWM IC)
D5 (Option)	ZD 6.8V/0.5W		

Applications Information (Continued)

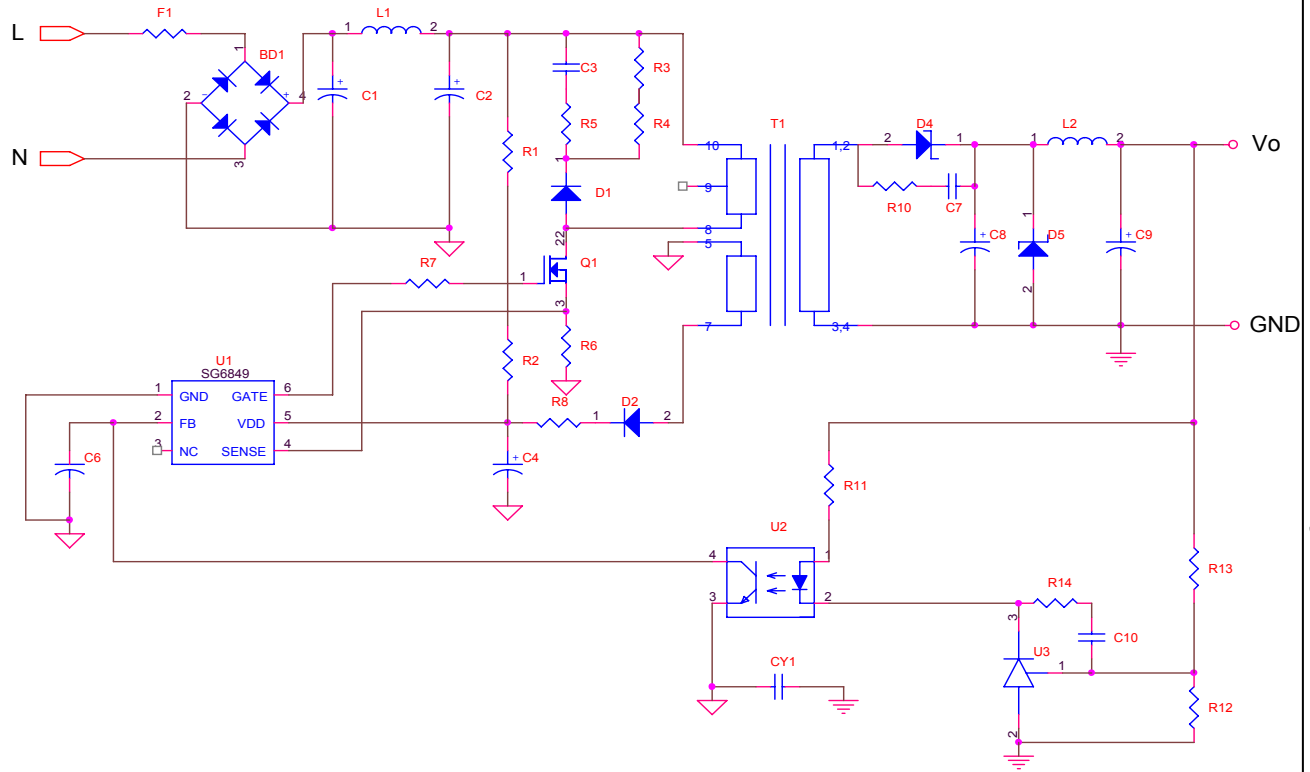
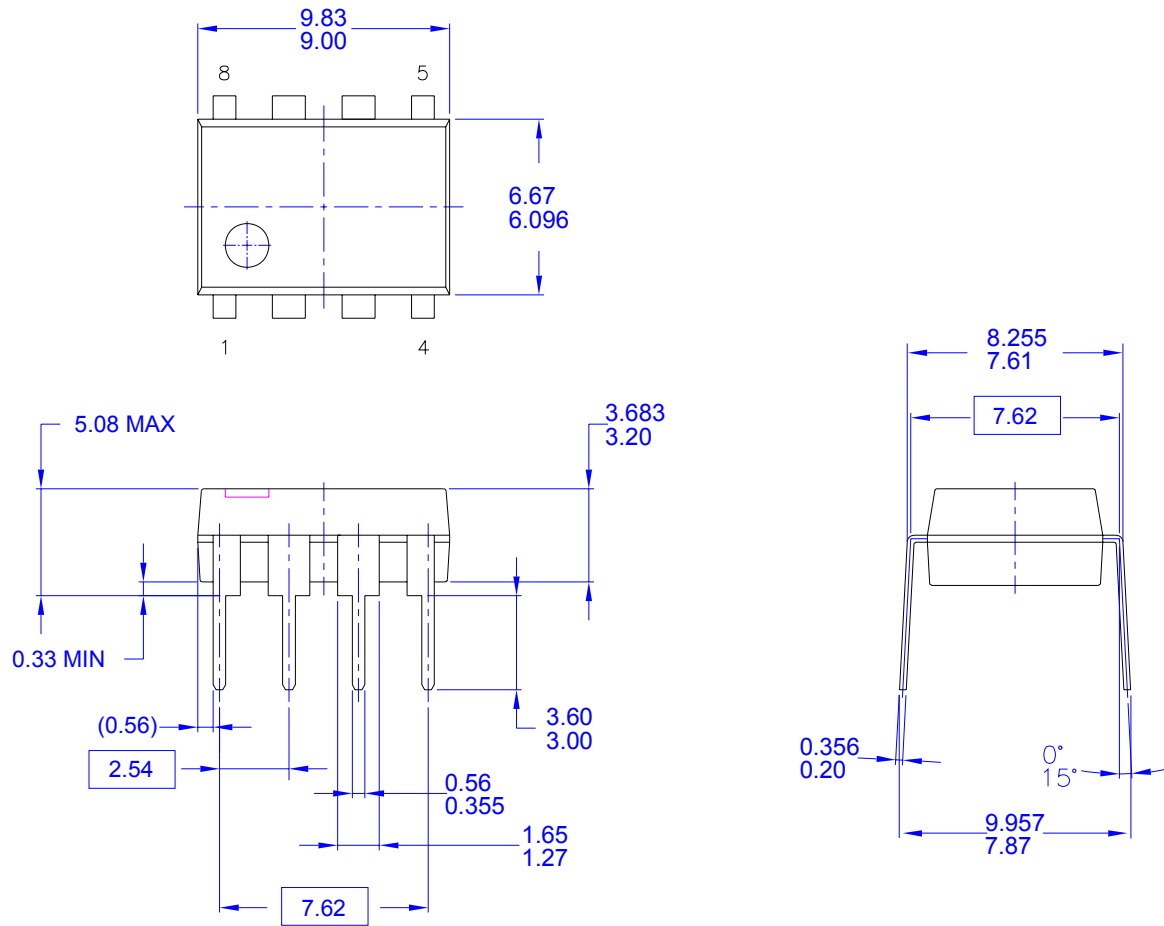

Figure 21. Reference Circuit (with Secondary-Side Feedback)

BOM

Reference	Component	Reference	Component
BD1	BD DI106 1A/600V	L2	Inductor 10 μ H 6mm
CY1 (Option)	YC 102p/400V	Q1	MOSFET 1A/600V
C1	CC 0.01 μ F/500V	R1,R2	R 750k Ω /1206
C2	EC 10 μ F/400V 105 $^{\circ}$ C	R4,R3	R 47k Ω /1206
C3	CC 1000p/500V	R5	R 47 Ω /1206
C4	EC 10 μ F50V	R6	R 4.7 Ω /0.5W
C6	CC 472p/0805	R7	R 100 Ω /0805
C7	CC 102p/100V 1206	R10	R 10 Ω /1206
C8	EC 470 μ F10V 105 $^{\circ}$ C	R8	R 10 Ω /1206
C9	EC 470 μ F10V 105 $^{\circ}$ C	R11	R 100 Ω /1/8W
C10	CC 222p/0805	R12	R 33k Ω /0805
D1	Diode FR107	R13	R 33k Ω /1/8W
D2	Diode FR102	R14	R 4.7k Ω /0805
D4	Diode SB360	T1	Transformer EE-16
D5 (Option)	ZD 6.8V/0.5W	U1	IC SG6849 (Green PWM IC)
F1	R 1 Ω /0.5W Resistor	U2	IC PC817
L1	Inductor 20mH 6*8mm	U3	IC TL431

Physical Dimensions



NOTES: UNLESS OTHERWISE SPECIFIED

- A) THIS PACKAGE CONFORMS TO JEDEC MS-001 VARIATION BA
- B) ALL DIMENSIONS ARE IN MILLIMETERS.
- C) DIMENSIONS ARE EXCLUSIVE OF BURRS, MOLD FLASH, AND TIE BAR EXTRUSIONS.
- D) DIMENSIONS AND TOLERANCES PER ASME Y14.5M-1994
- E) DRAWING FILENAME AND REVISION: MKT-N08FREV2.

Figure 22. 8-Pin Dual In-Line (DIP) Package

Package drawings are provided as a service to customers considering Fairchild components. Drawings may change in any manner without notice. Please note the revision and/or date on the drawing and contact a Fairchild Semiconductor representative to verify or obtain the most recent revision. Package specifications do not expand the terms of Fairchild's worldwide terms and conditions, specifically the warranty therein, which covers Fairchild products.

Physical Dimensions (Continued)

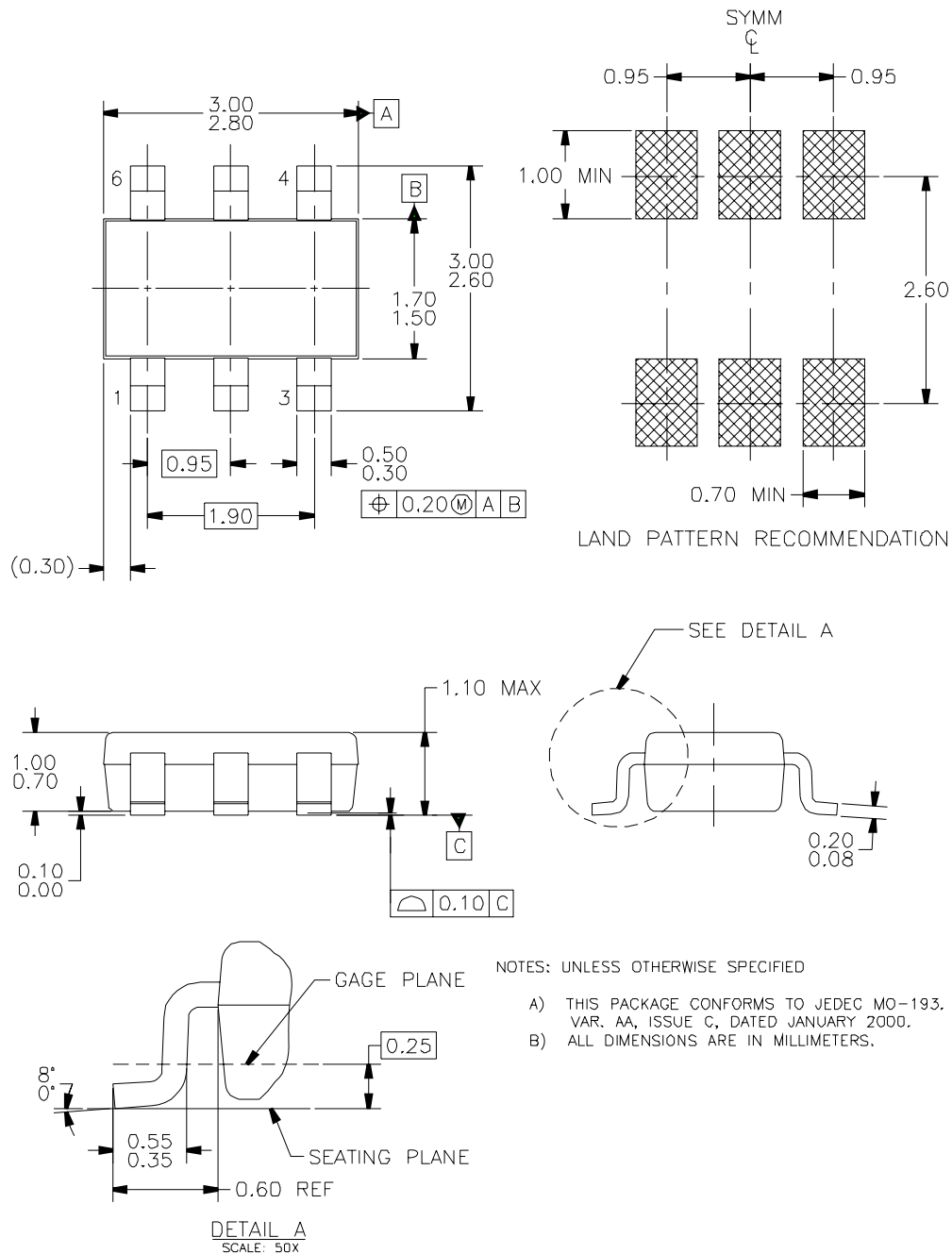

Figure 23. 6-Pin SSOT-6 Package

Package drawings are provided as a service to customers considering Fairchild components. Drawings may change in any manner without notice. Please note the revision and/or date on the drawing and contact a Fairchild Semiconductor representative to verify or obtain the most recent revision. Package specifications do not expand the terms of Fairchild's worldwide terms and conditions, specifically the warranty therein, which covers Fairchild products.

ON Semiconductor and  are trademarks of Semiconductor Components Industries, LLC dba ON Semiconductor or its subsidiaries in the United States and/or other countries. ON Semiconductor owns the rights to a number of patents, trademarks, copyrights, trade secrets, and other intellectual property. A listing of ON Semiconductor's product/patent coverage may be accessed at www.onsemi.com/site/pdf/Patent-Marking.pdf. ON Semiconductor reserves the right to make changes without further notice to any products herein. ON Semiconductor makes no warranty, representation or guarantee regarding the suitability of its products for any particular purpose, nor does ON Semiconductor assume any liability arising out of the application or use of any product or circuit, and specifically disclaims any and all liability, including without limitation special, consequential or incidental damages. Buyer is responsible for its products and applications using ON Semiconductor products, including compliance with all laws, regulations and safety requirements or standards, regardless of any support or applications information provided by ON Semiconductor. "Typical" parameters which may be provided in ON Semiconductor data sheets and/or specifications can and do vary in different applications and actual performance may vary over time. All operating parameters, including "Typicals" must be validated for each customer application by customer's technical experts. ON Semiconductor does not convey any license under its patent rights nor the rights of others. ON Semiconductor products are not designed, intended, or authorized for use as a critical component in life support systems or any FDA Class 3 medical devices or medical devices with a same or similar classification in a foreign jurisdiction or any devices intended for implantation in the human body. Should Buyer purchase or use ON Semiconductor products for any such unintended or unauthorized application, Buyer shall indemnify and hold ON Semiconductor and its officers, employees, subsidiaries, affiliates, and distributors harmless against all claims, costs, damages, and expenses, and reasonable attorney fees arising out of, directly or indirectly, any claim of personal injury or death associated with such unintended or unauthorized use, even if such claim alleges that ON Semiconductor was negligent regarding the design or manufacture of the part. ON Semiconductor is an Equal Opportunity/Affirmative Action Employer. This literature is subject to all applicable copyright laws and is not for resale in any manner.

PUBLICATION ORDERING INFORMATION

LITERATURE FULFILLMENT:

Email Requests to: orderlit@onsemi.com

ON Semiconductor Website: www.onsemi.com

TECHNICAL SUPPORT

North American Technical Support:
Voice Mail: 1 800-282-9855 Toll Free USA/Canada
Phone: 011 421 33 790 2910

Europe, Middle East and Africa Technical Support:

Phone: 00421 33 790 2910

For additional information, please contact your local Sales Representative