



# SG6858

## Low-Cost, Green-Mode, PWM Controller for Flyback Converters

### Features

- Green-Mode PWM
- Supports the "Blue Angel" Standard
- Low Startup Current: 10 $\mu$ A (Maximum)
- Low Operating Current: 2.5mA
- Leading-Edge Blanking (LEB)
- Constant Output Power Limit
- Built-in Synchronized Slope Compensation
- Current-Mode Operation
- Cycle-by-Cycle Current Limiting
- Under-Voltage Lockout (UVLO)
- Programmable PWM Frequency
- V<sub>DD</sub> Over-Voltage Protection with Auto-Restart
- Gate Output Voltage Clamped at 17V
- Few External Components Required
- SSOT-26 and DIP-8 Packages Available

### Applications

- Battery chargers for cellular phones, cordless phones, PDAs, digital cameras, and power tools
- Power adapters for ink jet printers, video game consoles, and portable audio players
- Open-frame SMPS for TV/DVD standby and other auxiliary supplies, home appliances, PC 5V standby power, and consumer electronics
- Replacements for linear transformers and RCC SMPS
- Offline High Brightness (HB) LED drivers

### Description

This highly integrated PWM controller provides several special enhancements designed to meet the low standby-power needs of low-power SMPS. To minimize standby power consumption, the proprietary green-mode function provides off-time modulation to linearly decrease the switching frequency under light-load conditions. This green-mode function enables the power supply to meet even the strictest power conservation requirements.

The BiCMOS fabrication process enables reducing the startup current to 10 $\mu$ A and the operating current to 2.5mA. To further improve power conservation, a large startup resistance can be used. Built-in synchronized slope compensation ensures the stability of peak-current-mode control. Proprietary internal compensation provides a constant output power limit over a universal AC input range (90V<sub>AC</sub> to 264V<sub>AC</sub>). Pulse-by-pulse current limiting ensures safe operation even during short circuits.

To protect the external power MOSFET from being damaged by supply over voltage, the output driver is clamped at 17V. SG6858 controllers can improve the performance and reduce the production cost of power supplies. The SG6858 replaces linear and RCC-mode power adapters. It is available in 8-pin DIP and 6-pin SSOT-26 packages.

### Ordering Information

Part Number	Operating Temperature Range	Eco Status	Package	Packing Method
SG6858TZ	-40 to +125°C	RoHS	6-Pin SSOT-26	Tape & Reel
SG6858DZ	-40 to +125°C	RoHS	8-Pin DIP-8	Tube

### Typical Application

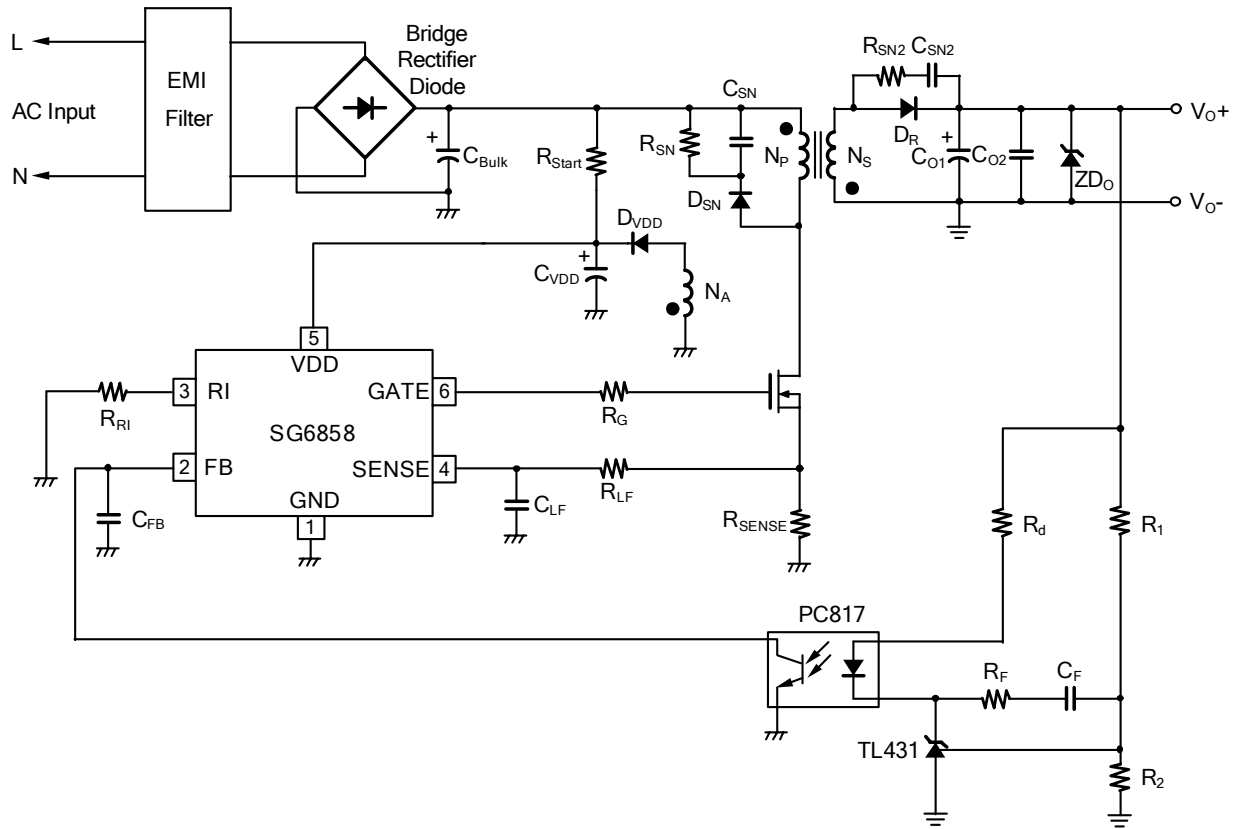

Figure 1. Typical Application

### Block Diagram

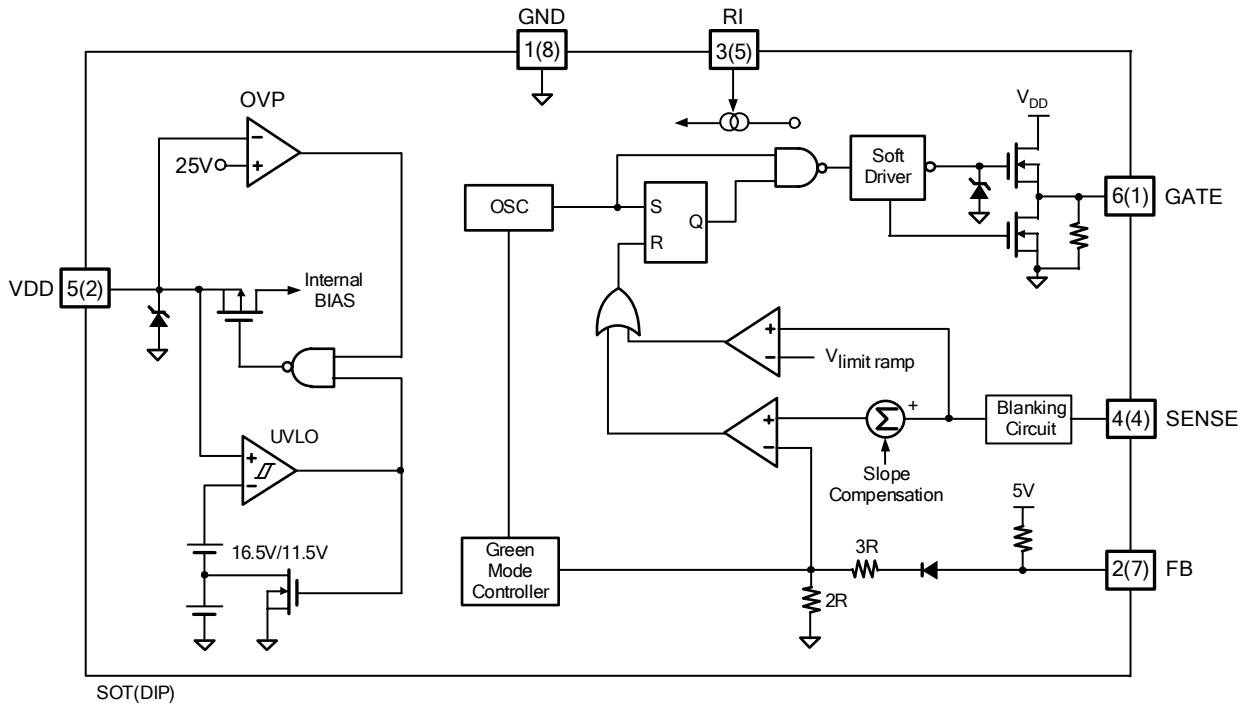
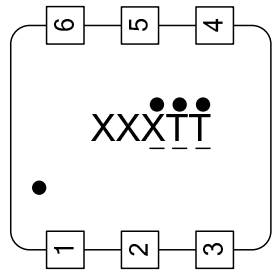

Figure 2. Block Diagram

### Marking Information



XXX:AAI=SG6858  
 TT: Die run code  
 ●: Year code  
 — : Week code

Figure 3. SSOT-26

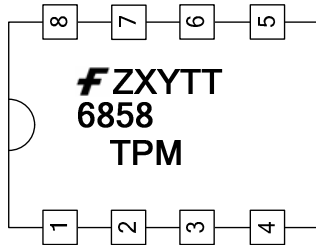

F: Fairchild Logo  
 Z: Assembly Plant Code  
 X: Year Code  
 Y: Week Code  
 TT: Die Run Code  
 T: N=DIP  
 P: Y=Green Package  
 M: Manufacture flow code

Figure 4. DIP-8

### Pin Configuration

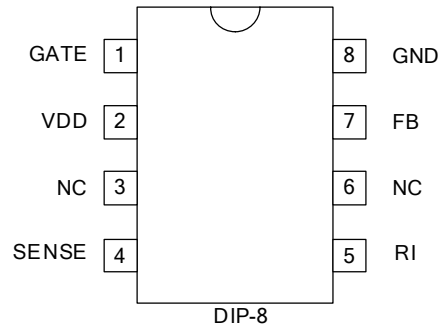
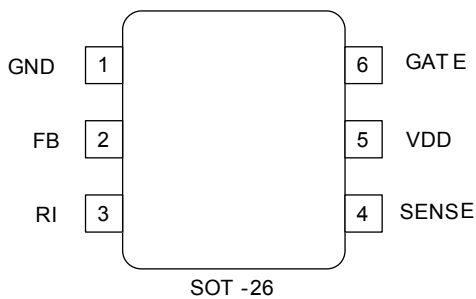

Figure 5. Pin Configurations

### Pin Definitions

Pin #		Name	Description
DIP-8	SSOT-26		
1	6	GATE	Totem-pole output driver for the power MOSFET.
2	5	VDD	Power supply.
3		NC	No connection.
4	4	SENSE	Current sense. This pin senses the voltage across a resistor. When the voltage reaches the internal threshold, PWM output is disabled. This activates over-current protection. This pin provides current amplitude information for current-mode control.
5	3	RI	A resistor connected from the RI pin to ground generates a constant current source. This current is used to charge an internal capacitor to determine the switching frequency. Increasing the resistance reduces the amplitude of the current source and reduces the switching frequency. A 95kΩ resistor, R <sub>i</sub> , results in a 50μA constant current, I <sub>i</sub> , and a 70kHz switching frequency.
6		NC	No connection.
7	2	FB	Feedback. The FB pin provides the output voltage regulation signal, and feedback to the internal PWM comparator, so the PWM comparator can control the duty cycle.
8	1	GND	Ground.

## Absolute Maximum Ratings

Stresses exceeding the absolute maximum ratings may damage the device. The device may not function or be operable above the recommended operating conditions and stressing the parts to these levels is not recommended. In addition, extended exposure to stresses above the recommended operating conditions may affect device reliability. The absolute maximum ratings are stress ratings only. All voltage values, except differential voltages, are given with respect to GND pin.

Symbol	Parameter	Min.	Max.	Unit
V <sub>DD</sub>	Supply Voltage		30	V
V <sub>FB</sub>	Input Voltage to FB Pin	-0.3	7.0	V
V <sub>SENSE</sub>	Input Voltage to SENSE Pin	-0.3	7.0	V
R <sub>θJC</sub>	Thermal Resistance (Junction-to-Case)	SSOT	208.4	°C/W
		DIP	82.5	
T <sub>J</sub>	Operating Junction Temperature	-40	+125	°C
T <sub>STG</sub>	Storage Temperature Range	-55	+150	°C
T <sub>L</sub>	Lead Temperature, Wave Soldering, 10 Seconds		260	°C
ESD	Electrostatic Discharge Capability	Human Body Model, JESD22-A114	3.0	kV
		Machine Model, JESD22-A115	0.2	

## Recommended Operating Conditions

The Recommended Operating Conditions table defines the conditions for actual device operation. Recommended operating conditions are specified to ensure optimal performance to the datasheet specifications. Fairchild does not recommend exceeding them or designing to Absolute Maximum Ratings.

Symbol	Parameter	Min.	Max.	Unit
V <sub>DD</sub>	DC Supply Voltage		22	V
T <sub>A</sub>	Operating Ambient Temperature	-40	+125	°C

## Electrical Characteristics

$V_{DD}=15V$ ,  $T_A=-40^{\circ}C \sim +125^{\circ}C$  ( $T_A = T_J$ ), unless otherwise specified.

Symbol	Parameter	Test Condition	Min.	Typ.	Max.	Unit
<b>V<sub>DD</sub> Section</b>						
$V_{DD-OP}$	Continuously Operating Voltage				22	V
$V_{DD-ON}$	Turn-On Threshold Voltage		15.5	16.5	17.5	V
$V_{DD-OFF}$	Turn-Off Voltage		10.5	11.5	12.5	V
$I_{DD-ST}$	Startup Current	$V_{DD}=V_{DD-ON} - 0.1V$		10	15	$\mu A$
$I_{DD-OP}$	Operating Supply Current	$V_{DD}=15V$ , GATE with 1nF to GND		2.5	3.5	mA
$V_{DD-OVP}$	$V_{DD}$ Over-Voltage Protection Level		23	25	26	V
$t_{D-VDDOVP}$	$V_{DD}$ OVP Debounce Time		50	125	200	$\mu sec$
$V_{DD-G OFF}$	$V_{DD}$ Low Threshold Voltage to Exit Green Off Mode		$V_{DD-OFF} + 0.95$	$V_{DD-OFF} + 1.10$	$V_{DD-OFF} + 1.25$	V
<b>Feedback Input Section</b>						
$A_V$	FB Input to Current Comparator Attenuation			2/5		V/V
$Z_{FB}$	Input Impedance			5		k $\Omega$
$V_{FB-OPEN}$	FB Pin Open High Voltage		4.5	5.0	5.5	V
$V_{FB-N}$	Green Mode Entry FB Voltage			2.85		V
$V_{FB-G}$	Green Mode Ending FB Voltage			2.20		V
$S_G$	Green Mode Modulation Slope	$R_I=95k\Omega$		75		Hz/mV
<b>Current Sense Section</b>						
$Z_{SENSE}$	Input Impedance		10			k $\Omega$
$t_{PD}$	Delay to Output			60	110	ns
$V_{STHFL}$	Flat Threshold Voltage for Current Limit			0.96		V
$V_{STHVA}$	Valley Threshold Voltage for Current Limit		0.75	0.80	0.85	V
$t_{LEB}$	Leading-Edge Blanking Time		240	300	360	ns
$DCY_{SAW}$	Duty Cycle of SAW Limit	Maximum Duty Cycle		45		%
<b>Oscillator Section</b>						
$f_{OSC}$	Frequency	$R_I=95k\Omega$	65	70	75	kHz
$f_{OSC-G}$	Green Mode Frequency	$R_I=95k\Omega$		22		kHz
$f_{DV}$	Frequency Variation vs. $V_{DD}$ Deviation	$V_{DD}=13.5V$ to 22V	0	0.02	2.00	%
$f_{DT}$	Frequency Variation vs. Temperature Deviation	$T_A=-40^{\circ}C \sim +125^{\circ}C$			2	%
<b>Output Section</b>						
$DCY_{MAX}$	Maximum Duty Cycle		70	75	80	%
$V_{GATE-L}$	Output Voltage Low	$V_{DD}=15V$ , $I_O=20mA$			1.5	V
$V_{GATE-H}$	Output Voltage High	$V_{DD}=13.5V$ , $I_O=20mA$	8			V
$t_R$	Rising Time	$V_{DD}=13.5V$ , $C_L=1nF$	100	170	240	ns
$t_F$	Falling Time	$V_{DD}=13.5V$ , $C_L=1nF$	35	55	75	ns
$V_{GATE-CLAMP}$	Output Clamp Voltage	$V_{DD}=13.5V$ , $T_A=25^{\circ}C$	16	17	18	V

## Typical Performance Characteristics

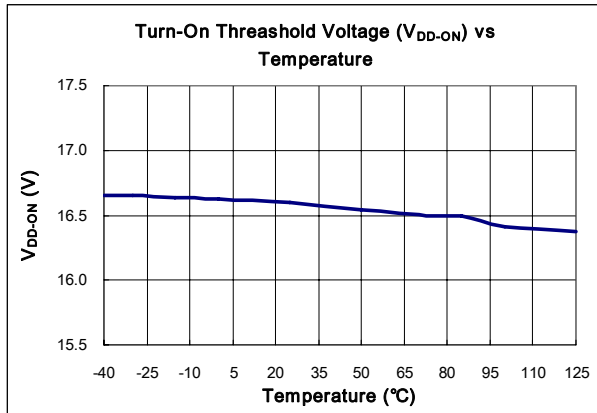

Figure 6. Turn-On Threshold Voltage (V<sub>DD-ON</sub>) vs. Temperature

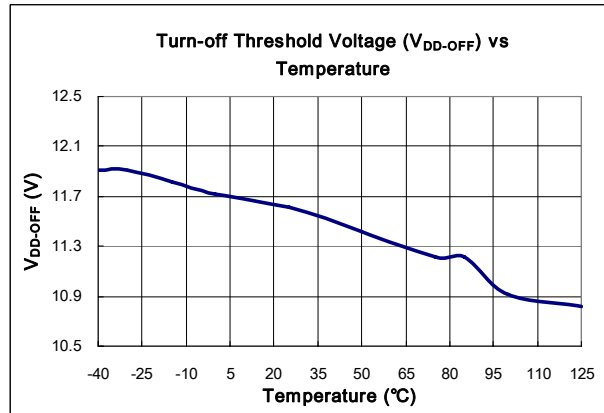

Figure 7. Turn-off Threshold Voltage (V<sub>DD-OFF</sub>) vs. Temperature

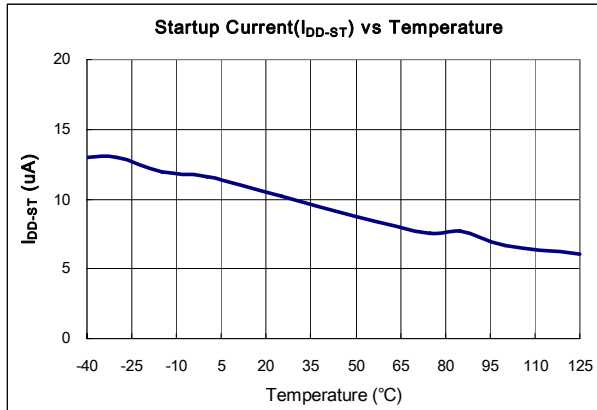

Figure 8. Startup Current (I<sub>DD-ST</sub>) vs. Temperature

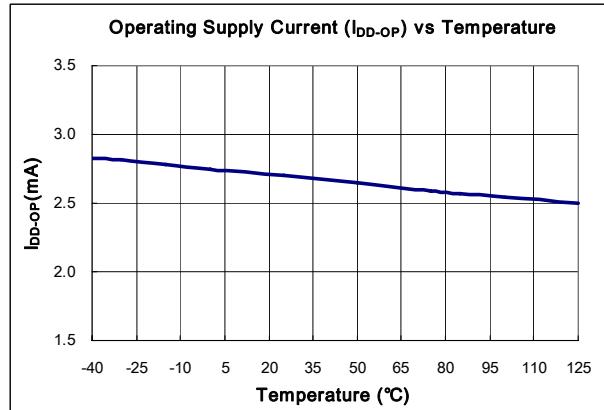

Figure 9. Operating Supply Current (I<sub>DD-OP</sub>) vs. Temperature

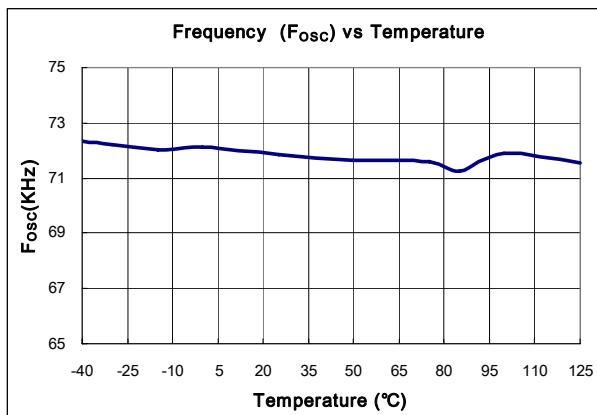

Figure 10. Frequency (f<sub>osc</sub>) vs. Temperature

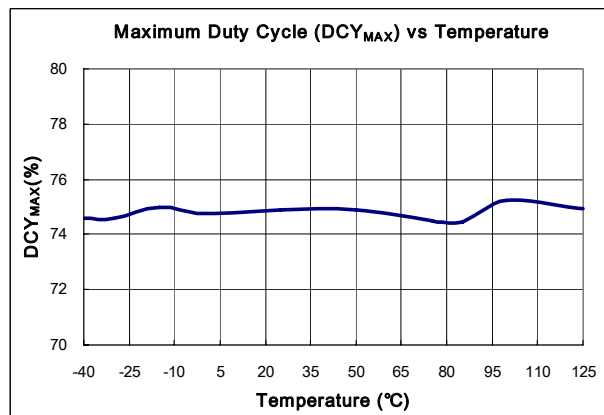
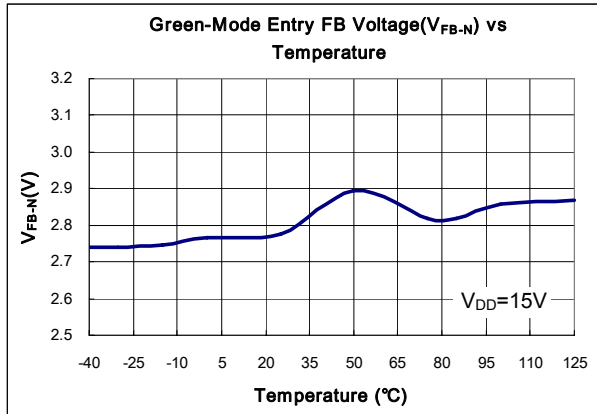
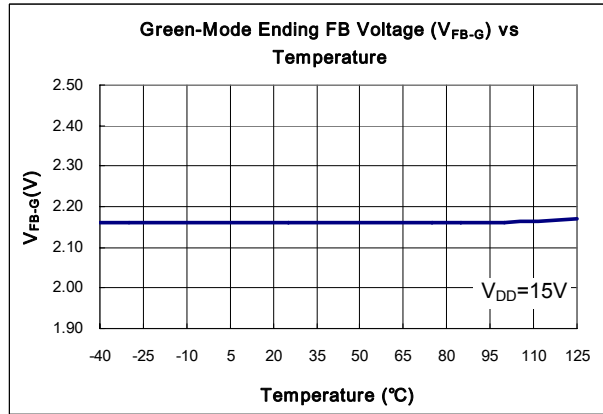

Figure 11. Maximum Duty Cycle (DCY<sub>MAX</sub>) vs. Temperature

**Typical Performance Characteristics** (Continued)



**Figure 12. Green Mode Entry FB Voltage (V<sub>FB-N</sub>) vs. Temperature**



**Figure 13. Green Mode Ending FB Voltage (V<sub>FB-G</sub>) vs. Temperature**

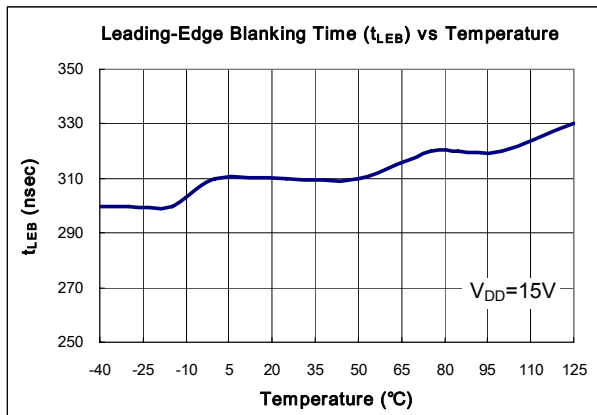

**Figure 14. Leading-Edge Blanking Time (t<sub>LEB</sub>) vs. Temperature**

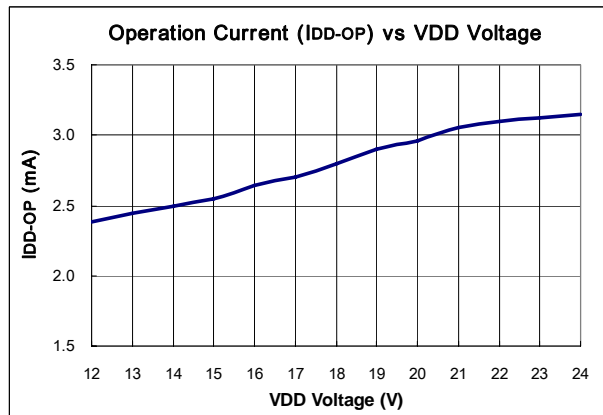

**Figure 15. Operating Current (I<sub>DD-OP</sub>) vs. Temperature**

## Operation Description

SG6858 devices integrate many useful designs into one controller for low-power switch-mode power supplies. The following descriptions highlight some of the features of the SG6858 series.

### Startup Operation

The startup current is only 10 $\mu$ A. Low startup current allows a startup resistor with a high resistance and low wattage to supply the startup power for the controller. A 1.5M $\Omega$ , 0.25W, startup resistor and a 10 $\mu$ F/25V  $V_{DD}$  hold-up capacitor would be sufficient for an AC-to-DC power adapter with a wide input range (100V<sub>AC</sub> to 240V<sub>AC</sub>).

### Operating Current

The operating current has been reduced to 2.5mA. The low operating current results in higher efficiency and reduces the  $V_{DD}$  hold-up capacitance requirement.

### Green-Mode Operation

The proprietary green-mode function provides off-time modulation to linearly decrease the switching frequency under light-load conditions. On-time is limited to provide stronger protection against brownouts and other abnormal conditions. The feedback current, which is sampled from the voltage feedback loop, is taken as the reference. Once the feedback current exceeds the threshold current, the switching frequency starts to decrease. This green-mode function dramatically reduces power consumption under light-load and zero-load conditions. Power supplies using the SG6858 meet the strictest regulations regarding standby power consumption.

### Oscillator Operation

A resistor connected from the RI pin to ground generates a constant current source for the SG6858. This current is used to charge an internal capacitor. The charge-time determines the internal clock speed and the switching frequency. Increasing the resistance reduces the amplitude of the input current and reduces the switching frequency. A 95k $\Omega$  resistor  $R_I$  results in a 50 $\mu$ A constant current  $I_I$  and a 70kHz switching frequency. The relationship between  $R_I$  and the switching frequency is:

$$f_{PWM} = \frac{6650}{R_I \text{ (k}\Omega\text{)}} \text{ (kHz)} \quad (1)$$

### Leading-Edge Blanking (LEB)

Each time the power MOSFET is switched on, a turn-on spike occurs at the sense-resistor. To avoid premature termination of the switching pulse, a 300ns leading-edge blanking time is built in. Conventional RC filtering can therefore be omitted. During this blanking period, the current-limit comparator is disabled and it cannot switch off the gate driver.

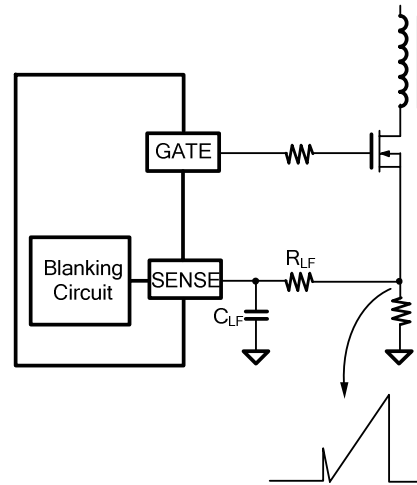

Figure 16. Current Sense R-C Filter

### Constant Output Power Limit

When the SENSE voltage across the sense resistor  $R_S$  reaches the threshold voltage (around 0.96V), the output GATE drive is turned off following a short propagation delay  $t_{PD}$ .

This propagation delay introduces an additional current proportional to  $t_{PD} \cdot V_{IN} / L_P$ . The propagation delay is nearly constant regardless of the input line voltage  $V_{IN}$ . Higher input line voltages result in larger additional currents. At high input line voltages, the output power limit is higher than at low input line voltages.

To compensate for this output power limit variation across a wide AC input range, the threshold voltage is adjusted by adding a positive ramp ( $V_{LIMIT\_RAMP}$ ).

This ramp signal rises from 0.80V to 0.96V, then flattens out at 0.96V. A smaller threshold voltage forces the output GATE drive to terminate earlier. This reduces the total PWM turn-on time and makes the output power equal to that of low line input. This proprietary internal compensation ensures a constant output power limit for a wide AC input voltage range (90V<sub>AC</sub> to 264V<sub>AC</sub>).

### Under-Voltage Lockout (UVLO)

The turn-on and turn-off thresholds are fixed internally at 16.5V/11.5V. During startup, the hold-up capacitor must be charged to 16.5V through the startup resistor, so that the SG6858 is enabled. The hold-up capacitor continues to supply  $V_{DD}$  until power can be delivered from the auxiliary winding of the main transformer.  $V_{DD}$  must not drop below 11.5V during this startup process. This UVLO hysteresis window ensures that the hold-up capacitor is adequate to supply  $V_{DD}$  during startup.



### **V<sub>DD</sub> Over-Voltage Protection (OVP)**

Integrated V<sub>DD</sub> over-voltage protection prevents damage due to over-voltage conditions. When the V<sub>DD</sub> exceeds the internal threshold due to abnormal conditions, PWM output is turned off until the V<sub>DD</sub> voltage drops below the UVLO, then starts again. Over-voltage conditions are usually caused by open feedback loops.

### **Gate Output**

The BiCMOS output stage is a fast totem-pole gate driver. Cross conduction has been avoided to minimize heat dissipation, increase efficiency, and enhance reliability. The output driver is clamped by an internal 17V Zener diode to protect power MOSFET transistors against undesired over-voltage gate signals.

### **Built-in Slope Compensation**

The sensed voltage across the current sense resistor is used for current mode control and pulse-by-pulse current limiting. Built-in slope compensation improves stability and prevents sub-harmonic oscillations due to peak-current mode control. The SG6858 has a synchronized, positively-sloped ramp built-in at each switching cycle. The slope of the ramp is:

$$\frac{0.36 \times Duty}{Duty(max.)} \quad (2)$$

### **Noise Immunity**

Noise from the current sense or the control signal can cause significant pulsewidth jitter, particularly in continuous-conduction mode. While slope compensation helps alleviate this problem, further precautions should be taken. Good placement and layout practices should be followed. Avoiding long PCB traces and component leads, locating compensation and filter components near the SG6858, and increasing the power MOS gate resistance are advised.

### Typical Application Circuit (Flyback Converter for Printer Application)

Application	Fairchild Devices	Input Voltage Range	Output
Adapter	SG6858	90~264V <sub>AC</sub>	12V/1.25A (15W)

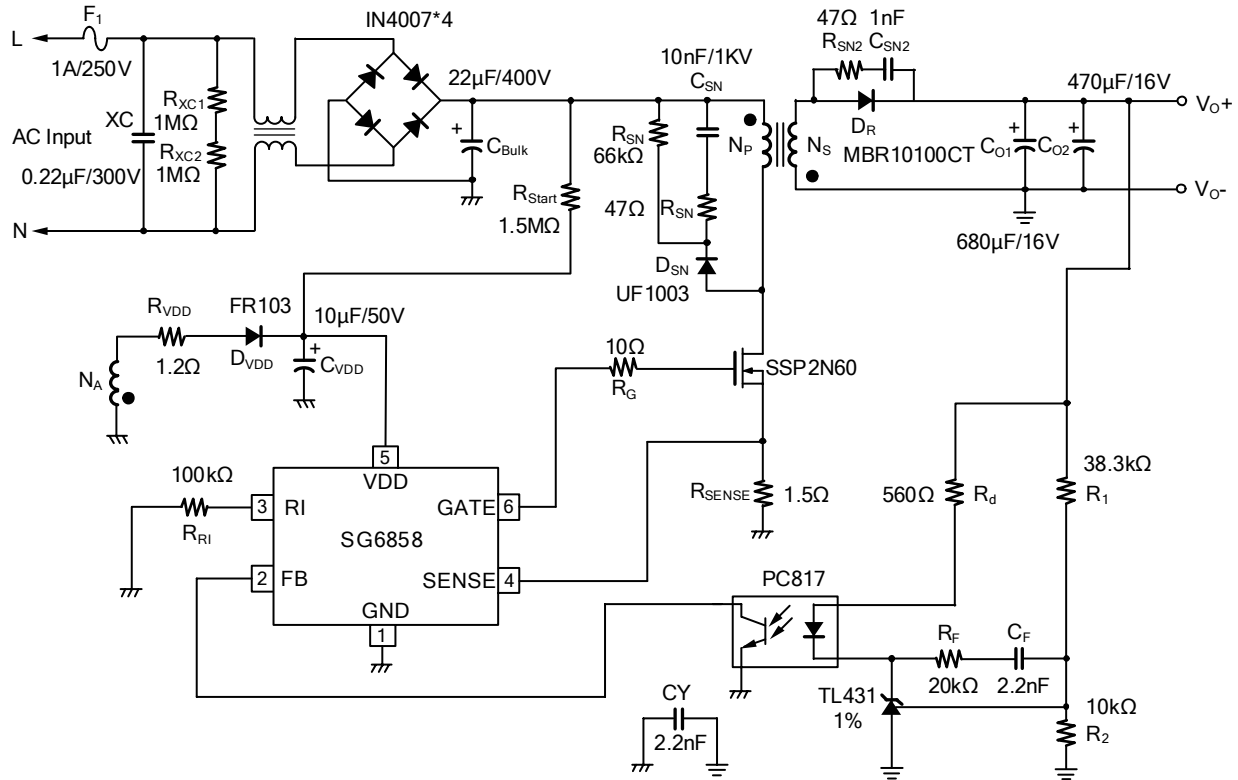

Figure 17. Schematic of Application Circuit

### Transformer

- Core: EF-20
- Primary-Side Inductance: 2mH (Pin1 to Pin3)

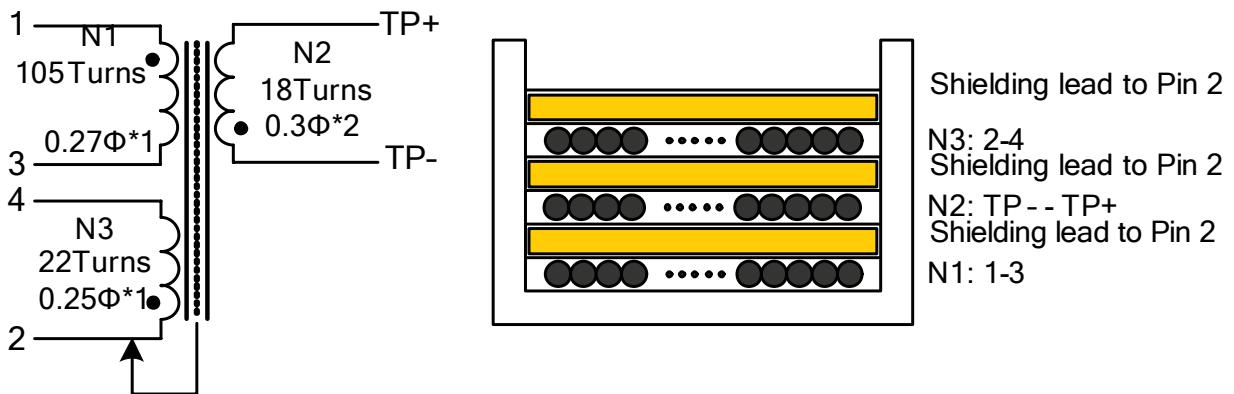

Figure 18. Transformer Structure

Physical Dimensions

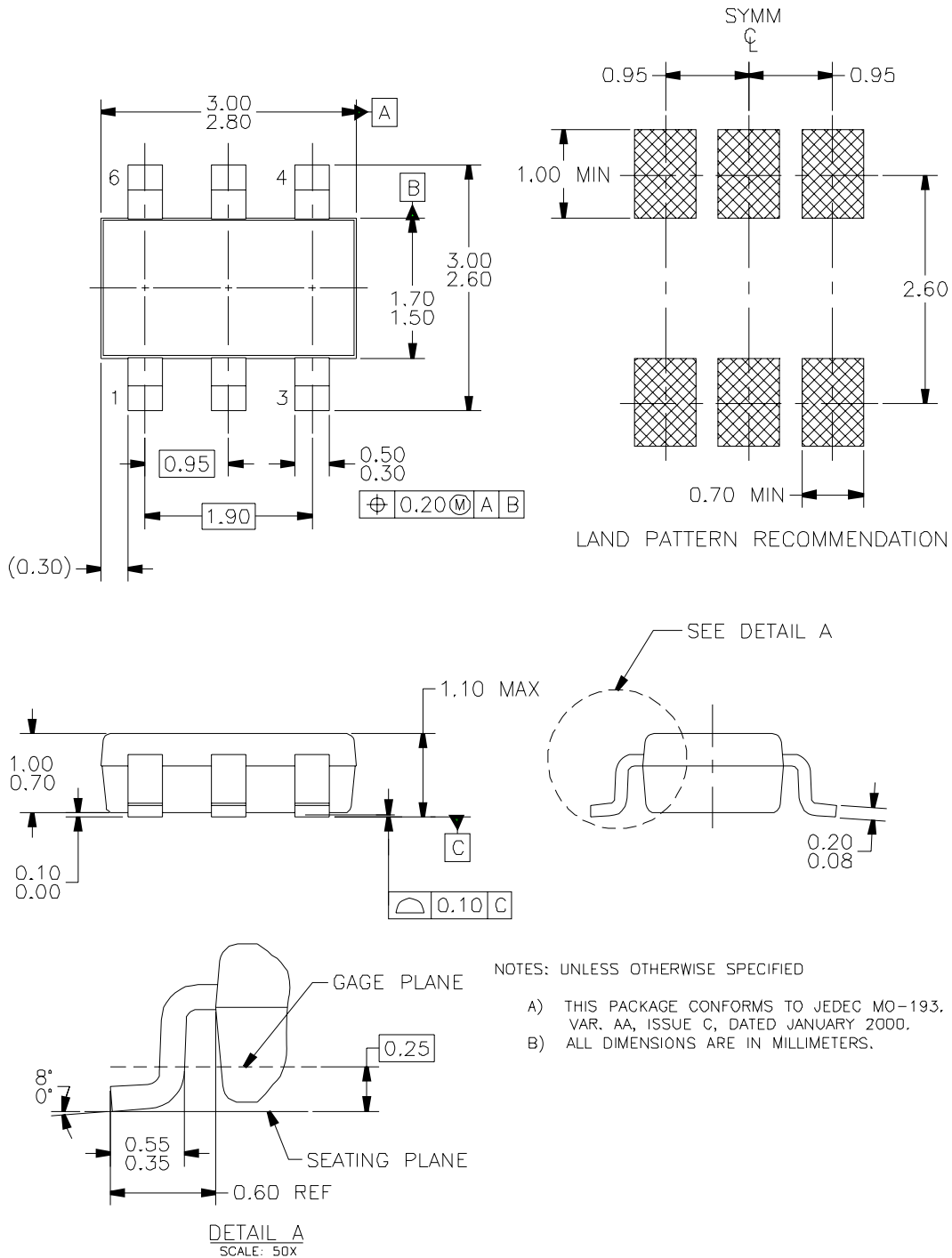
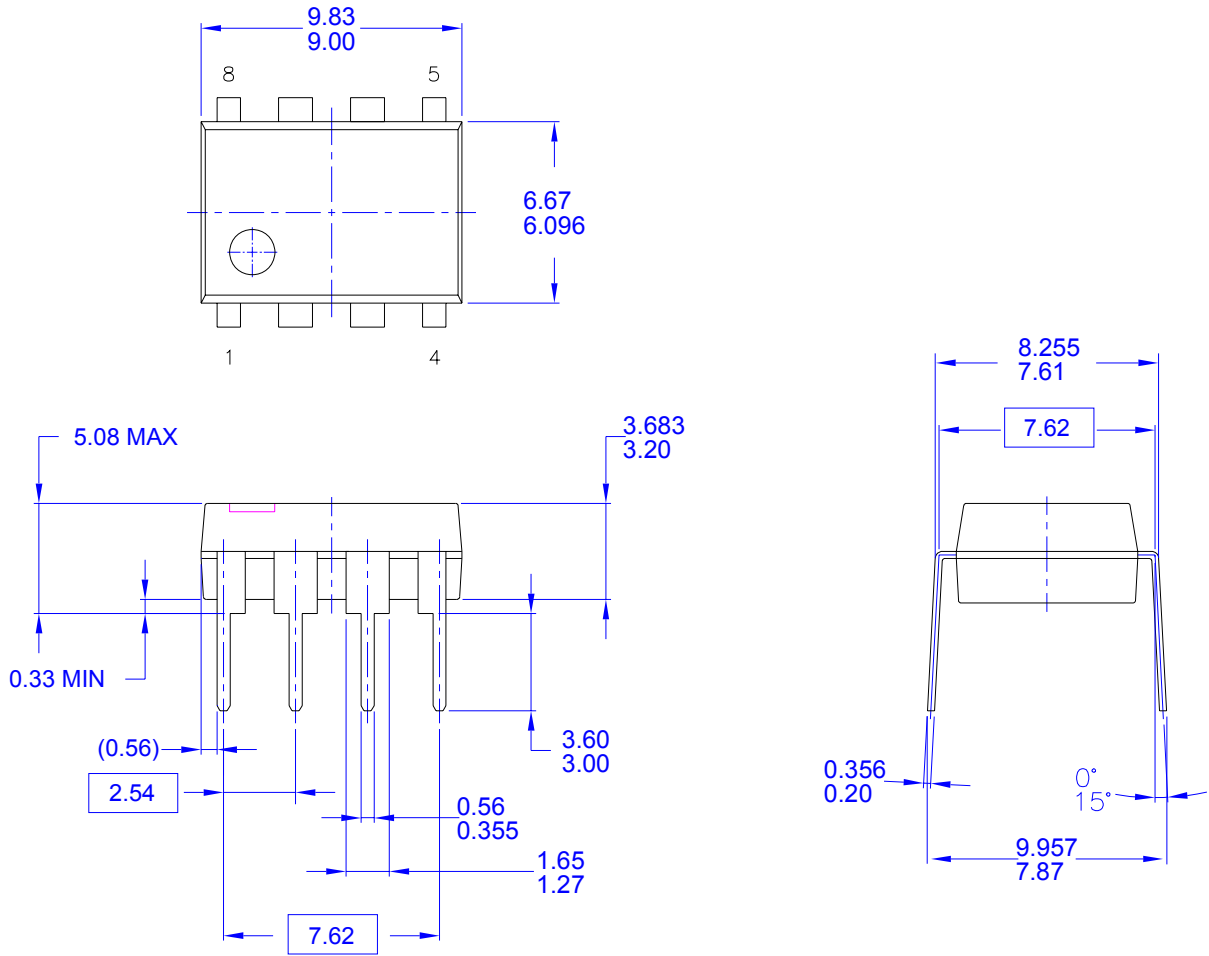

Figure 19. 6-Pin, SSOT-6 Package

Package drawings are provided as a service to customers considering Fairchild components. Drawings may change in any manner without notice. Please note the revision and/or date on the drawing and contact a Fairchild Semiconductor representative to verify or obtain the most recent revision. Package specifications do not expand the terms of Fairchild's worldwide terms and conditions, specifically the warranty therein, which covers Fairchild products.

**Physical Dimensions** (Continued)



**NOTES: UNLESS OTHERWISE SPECIFIED**

- A) THIS PACKAGE CONFORMS TO JEDEC MS-001 VARIATION BA
- B) ALL DIMENSIONS ARE IN MILLIMETERS.
- C) DIMENSIONS ARE EXCLUSIVE OF BURRS, MOLD FLASH, AND TIE BAR EXTRUSIONS.
- D) DIMENSIONS AND TOLERANCES PER ASME Y14.5M-1994
- E) DRAWING FILENAME AND REVISION: MKT-N08FRE2.

**Figure 20. 8-Pin, Dual-Inline Package (DIP-8)**

*Package drawings are provided as a service to customers considering Fairchild components. Drawings may change in any manner without notice. Please note the revision and/or date on the drawing and contact a Fairchild Semiconductor representative to verify or obtain the most recent revision. Package specifications do not expand the terms of Fairchild's worldwide terms and conditions, specifically the warranty therein, which covers Fairchild products.*

ON Semiconductor and  are trademarks of Semiconductor Components Industries, LLC dba ON Semiconductor or its subsidiaries in the United States and/or other countries. ON Semiconductor owns the rights to a number of patents, trademarks, copyrights, trade secrets, and other intellectual property. A listing of ON Semiconductor's product/patent coverage may be accessed at [www.onsemi.com/site/pdf/Patent-Marking.pdf](http://www.onsemi.com/site/pdf/Patent-Marking.pdf). ON Semiconductor reserves the right to make changes without further notice to any products herein. ON Semiconductor makes no warranty, representation or guarantee regarding the suitability of its products for any particular purpose, nor does ON Semiconductor assume any liability arising out of the application or use of any product or circuit, and specifically disclaims any and all liability, including without limitation special, consequential or incidental damages. Buyer is responsible for its products and applications using ON Semiconductor products, including compliance with all laws, regulations and safety requirements or standards, regardless of any support or applications information provided by ON Semiconductor. "Typical" parameters which may be provided in ON Semiconductor data sheets and/or specifications can and do vary in different applications and actual performance may vary over time. All operating parameters, including "Typicals" must be validated for each customer application by customer's technical experts. ON Semiconductor does not convey any license under its patent rights nor the rights of others. ON Semiconductor products are not designed, intended, or authorized for use as a critical component in life support systems or any FDA Class 3 medical devices or medical devices with a same or similar classification in a foreign jurisdiction or any devices intended for implantation in the human body. Should Buyer purchase or use ON Semiconductor products for any such unintended or unauthorized application, Buyer shall indemnify and hold ON Semiconductor and its officers, employees, subsidiaries, affiliates, and distributors harmless against all claims, costs, damages, and expenses, and reasonable attorney fees arising out of, directly or indirectly, any claim of personal injury or death associated with such unintended or unauthorized use, even if such claim alleges that ON Semiconductor was negligent regarding the design or manufacture of the part. ON Semiconductor is an Equal Opportunity/Affirmative Action Employer. This literature is subject to all applicable copyright laws and is not for resale in any manner.

## PUBLICATION ORDERING INFORMATION

### LITERATURE FULFILLMENT:

Email Requests to: [orderlit@onsemi.com](mailto:orderlit@onsemi.com)

ON Semiconductor Website: [www.onsemi.com](http://www.onsemi.com)

### TECHNICAL SUPPORT

North American Technical Support:  
Voice Mail: 1 800-282-9855 Toll Free USA/Canada  
Phone: 011 421 33 790 2910

Europe, Middle East and Africa Technical Support:

Phone: 00421 33 790 2910

For additional information, please contact your local Sales Representative