

## FEATURES

- Green-Mode PWM
- Supports the “Blue Angel” Standard
- Low Start-up Current (9uA)
- Low Operating Current (3mA)
- Leading-Edge Blanking
- Constant Output Power Limit
- Universal Input
- Built-in Synchronized Slope Compensation
- Current Mode Operation
- Cycle-by-cycle Current Limiting
- Under Voltage Lockout (UVLO)
- Programmable PWM Frequency with Frequency Hopping
- V<sub>DD</sub> Over Voltage Protection (Auto Restart)
- Gate Output Voltage Clamped at 17V
- Low Cost
- Few External Components Required
- Small SOT-26 and Dip 8 Packages

## APPLICATIONS

General-purpose switching mode power supplies and flyback power converters, such as

- Battery chargers for cellular phones, cordless phones, PDAs, digital cameras, and power tools
- Power adapters for ink jet printers, video game consoles, and portable audio players
- Open-frame SMPS for TV/DVD standby and other auxiliary supplies, home appliances, and consumer electronics
- Replacements for linear transformers and RCC SMPS
- PC 5V standby power.

## DESCRIPTION

This highly integrated PWM controller provides several special enhancements designed to meet the low standby-power needs of low-power SMPS. To minimize standby power consumption, the proprietary green-mode function provides off-time modulation to linearly decrease the switching frequency under light-load conditions. This green-mode function enables the power supply to easily meet even the strictest power conservation requirements.

The BiCMOS fabrication process enables reducing the start-up current to 9uA, and the operating current to 3mA. To further improve power conservation, a large start-up resistance can be used. Built-in synchronized slope compensation ensures the stability of peak current mode control. Proprietary internal compensation provides a constant output power limit over a universal AC input range (90V<sub>AC</sub> to 264V<sub>AC</sub>). Pulse-by-pulse current limiting ensures safe operation even during short-circuits.

To protect the external power MOSFET from being damaged by supply over voltage, the SG6859’s output driver is clamped at 17V. SG6859 controllers can be used to improve the performance and reduce the production cost of power supplies. The SG6859 is the best choice for replacing linear and RCC-mode power adapters. It is available in 8-pin DIP and 6-pin SOT-26 packages.

## TYPICAL APPLICATION

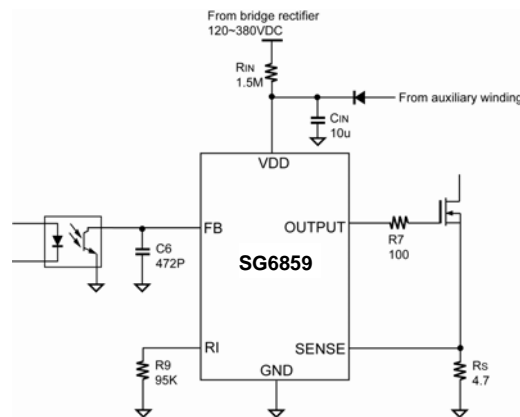

**MARKING DIAGRAMS**

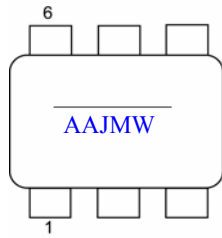

AAJ: SG6859  
M: Mask Version  
W: Week code A~Z=W1~W26  
A~Z=W27~W52  
— : Lead Free Package

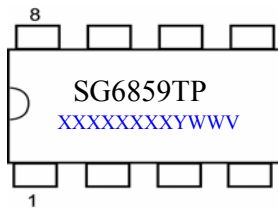

T: D=DIP  
P: Z=Lead Free  
Null=Regular Package  
XXXXXXXX: Wafer Lot  
Y: Year; WW: Week  
V: Assembly Location

**PIN CONFIGURATION**

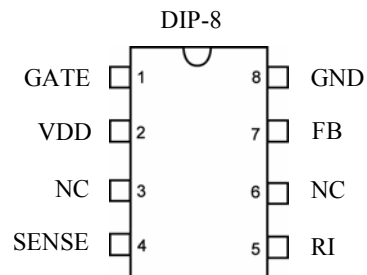
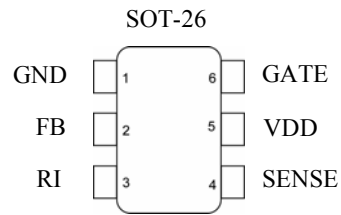

**ORDERING INFORMATION**

Part Number	Pb-Free	Package
SG6859TZ		6-Pin SOT-26
SG6859DZ		8-Pin DIP-8

**PIN DESCRIPTIONS**

Name	Pin No. DIP-8(SOT-26)	Type	Function
GATE	1 / (6)	Driver Output	The totem-pole output driver for driving the power MOSFET.
VDD	2 / (5)	Supply	Power supply.
NC	3		NC pin.
SENSE	4 / (4)	Analog Input	Current sense. This pin senses the voltage across a resistor. When the voltage reaches the internal threshold, PWM output is disabled. This activates over-current protection. This pin also provides current amplitude information for current-mode control.
RI	5 / (3)	Analog Input/Output	A resistor connected from the RI pin to ground will generate a constant current source for the SG6859. This current is used to charge an internal capacitor, to determine the switching frequency. Increasing the resistance will reduce the amplitude of the current source and reduce the switching frequency. A 95kΩ resistor R <sub>i</sub> results in a 50uA constant current I <sub>i</sub> and a 70kHz switching frequency.
NC	6		NC pin.
FB	7 / (2)	Analog Input	Feedback. The FB pin provides the output voltage regulation signal. It provides feedback to the internal PWM comparator, so that the PWM comparator can control the duty cycle.
GND	8 / (1)	Supply	Ground.

BLOCK DIAGRAM

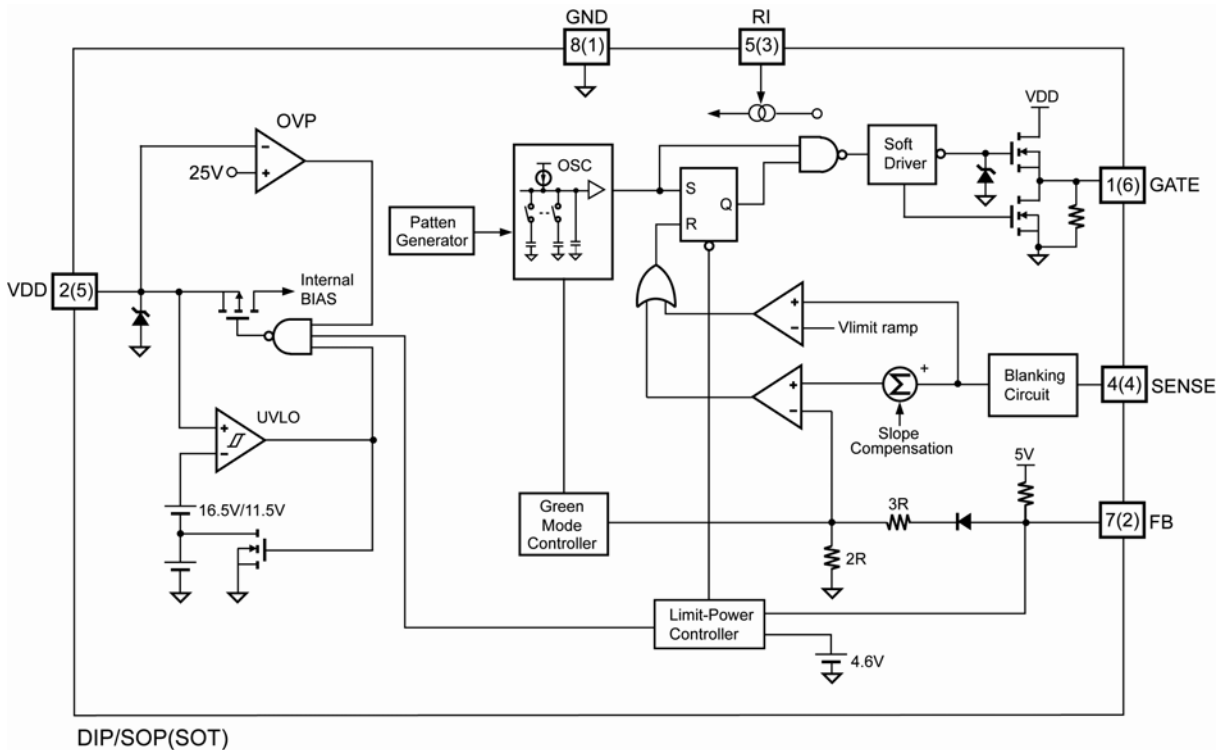

**Low Cost Green-Mode PWM Controller for Flyback Converters**
**SG6859**
**ABSOLUTE MAXIMUM RATINGS**

Symbol	Parameter	Value	Unit
V <sub>VDD</sub>	DC Supply Voltage *	30	V
V <sub>FB</sub>	Input Voltage to FB Pin	-0.3 to 7	V
V <sub>SENSE</sub>	Input Voltage to Sense Pin	-0.3 to 7	V
T <sub>J</sub>	Operating Junction Temperature	150	°C
R <sub>θJA</sub>	Thermal Resistance (Junction to Air)	SOT	208.4 °C/W
		DIP	82.5 °C/W
T <sub>STG</sub>	Storage Temperature Range	-55 to +150	°C
T <sub>L</sub>	Lead Temperature (Wave soldering or IR, 10 seconds)	260	°C
V <sub>ESD-HBM</sub>	ESD Capability, HBM Model	3.5	kV
V <sub>ESD-MM</sub>	ESD Capability, Machine Model	200	V

\* All voltage values, except differential voltages, are given with respect to GND pin.

\* Stresses beyond those listed under "absolute maximum ratings" may cause permanent damage to the device.

**RECOMMENDED OPERATING CONDITIONS**

Symbol	Parameter	Value	Unit
V <sub>DD</sub>	DC Supply Voltage	≤ 22	V
T <sub>A</sub>	Operating Ambient Temperature	-20 to +85	°C

\* For proper operation.

**ELECTRICAL CHARACTERISTICS (V<sub>DD</sub> = 15V; T<sub>A</sub> = 25°C)**
**VDD Section**

Symbol	Parameter	Test Condition	Min.	Typ.	Max.	Unit
V <sub>DD-OP</sub>	Continuously Operation Voltage				22	V
V <sub>DD-ON</sub>	Turn-On Threshold Voltage		15.5	16.5	17.5	V
V <sub>DD-OFF</sub>	Turn-Off Threshold Voltage		10.5	11.5	12.5	V
I <sub>DD-ST</sub>	Startup Current	V <sub>DD</sub> =V <sub>DD-ON</sub> - 0.1V		9	15	μA
I <sub>DD-OP</sub>	Operating Supply Current	V <sub>DD</sub> =15V, GATE with 1nF to GND		3	3.5	mA
V <sub>DD-OVP</sub>	VDD Over-voltage-protection level	(Auto Restart)	24	25	26	V
t <sub>D-VDDOVP</sub>	VDD Over-voltage-protection Debounce	(Auto Restart)		125		μs
V <sub>DD-G OFF</sub>	V <sub>DD</sub> Low-threshold Voltage to Exit Green-off Mode			V <sub>DD-OFF</sub> + 1		V

**Low Cost Green-Mode PWM Controller for Flyback Converters**
**SG6859**
**Feedback Input Section**

Symbol	Parameter	Test Condition	Min.	Typ.	Max.	Unit
Z <sub>FB</sub>	Input Impedance			5		KΩ
V <sub>FB-OPEN</sub>	FB Output High Voltage		5			V
V <sub>FB-OL</sub>	FB Open-loop Trigger Level		4.3	4.6	4.9	V
t <sub>D-OLP</sub>	The delay time of FB pin Open Loop Protection			56		ms
V <sub>FB-N</sub>	Green-Mode Entry FB Voltage		2.6	2.85	3.1	V
V <sub>FB-G</sub>	Green-Mode Ending FB Voltage			2.20		V
S <sub>G</sub>	Green-Mode Modulation Slope	R <sub>I</sub> =95KΩ	40	75	100	Hz/mV

**Current Sense Section**

Symbol	Parameter	Test Condition	Min.	Typ.	Max.	Unit
Z <sub>SENSE</sub>	Input Impedance		10			KΩ
t <sub>PD</sub>	Delay to Output		40	55	100	ns
V <sub>STHFL</sub>	Flat Threshold Voltage for Current Limit		0.91	0.96	1.01	V
V <sub>STHVA</sub>	Valley Threshold Voltage for Current Limit		0.75	0.80	0.85	V
t <sub>LEB</sub>	Leading-Edge Blanking Time		250	300	350	ns
DCY <sub>SAW</sub>	Duty Cycle of SAW Limit			40		%

**Oscillator Section**

Symbol	Parameter	Test Condition	Min.	Typ.	Max.	Unit	
F <sub>OSC</sub>	Normal PWM Frequency	Center Frequency	R <sub>I</sub> =95KΩ	65	70	75	KHz
		Hopping Range			±4.9		
T <sub>HOP</sub>	Hopping Period	R <sub>I</sub> =95KΩ		3.7		ms	
F <sub>OSC-G</sub>	Green-Mode Frequency	R <sub>I</sub> =95KΩ		22		KHz	
F <sub>DV</sub>	Frequency Variation versus V <sub>DD</sub> Deviation	V <sub>DD</sub> =13.5 to 22V	0	0.02	2	%	
F <sub>DT</sub>	Frequency Variation versus Temp. Deviation	T <sub>A</sub> =-20 to 85°C			2	%	

**Output Section**

Symbol	Parameter	Test Condition	Min.	Typ.	Max.	Unit
DCY <sub>MAX</sub>	Maximum Duty Cycle		70	75	80	%
V <sub>GATE-L</sub>	Output Voltage Low	V <sub>DD</sub> =15V, I <sub>o</sub> =20mA			1.5	V
V <sub>GATE-H</sub>	Output Voltage High	V <sub>DD</sub> =13.5V, I <sub>o</sub> =20mA	8			V
t <sub>r</sub>	Rising Time	V <sub>DD</sub> =15V, C <sub>L</sub> =1nF		150		ns
t <sub>f</sub>	Falling Time	V <sub>DD</sub> =15V, C <sub>L</sub> =1nF		55		ns
V <sub>GATE-CLAMP</sub>	Output Clamp Voltage	V <sub>DD</sub> =22V	16	17	18	V

TYPICAL CHARACTERISTICS

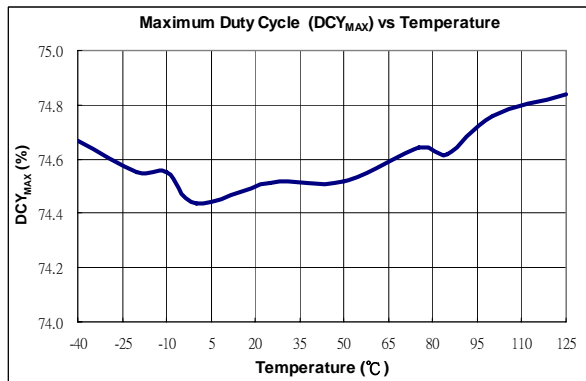
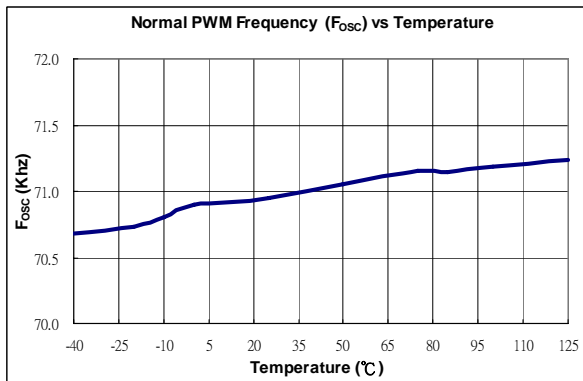
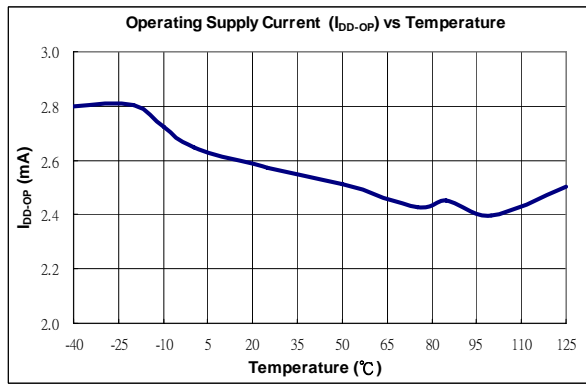
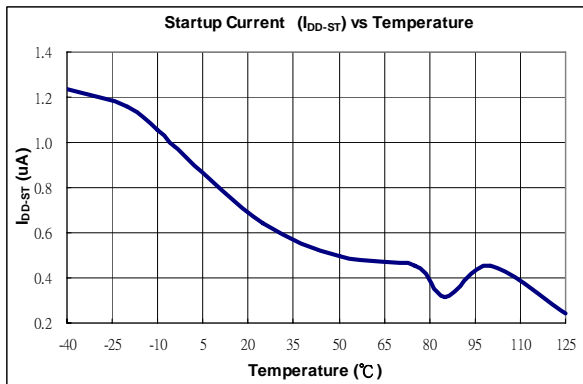
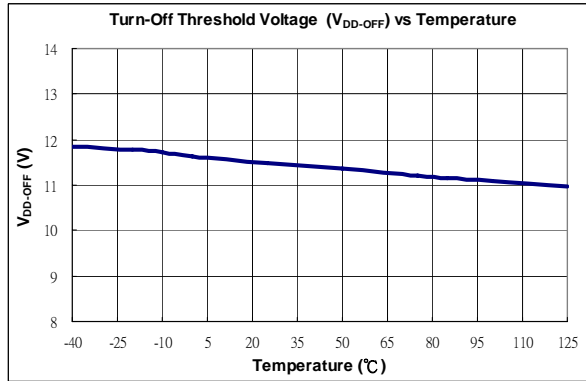
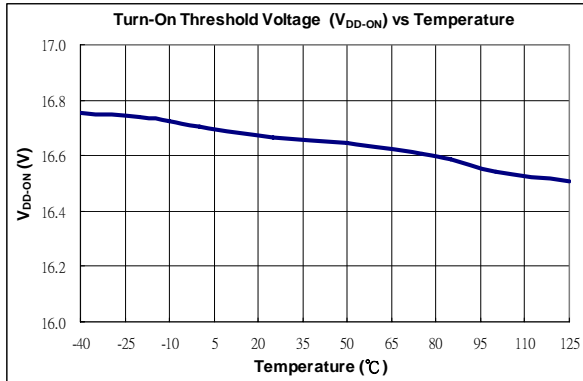

Low Cost Green-Mode PWM Controller for Flyback Converters

SG6859

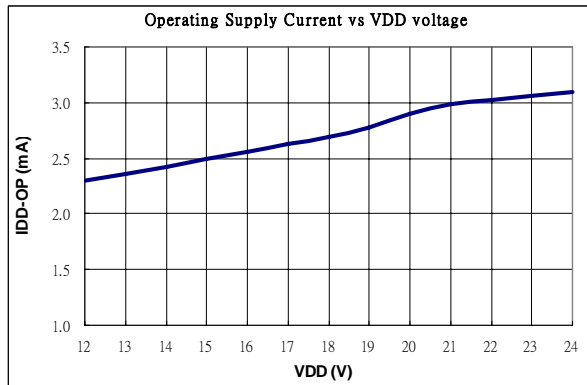
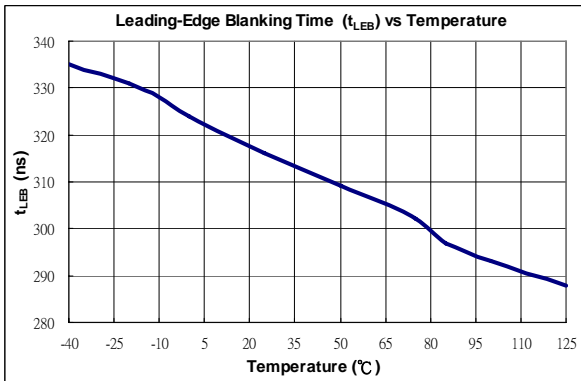
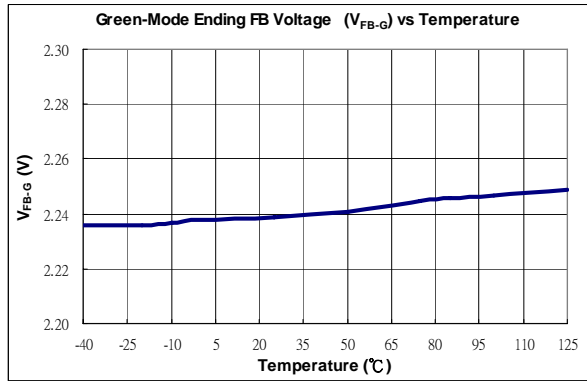
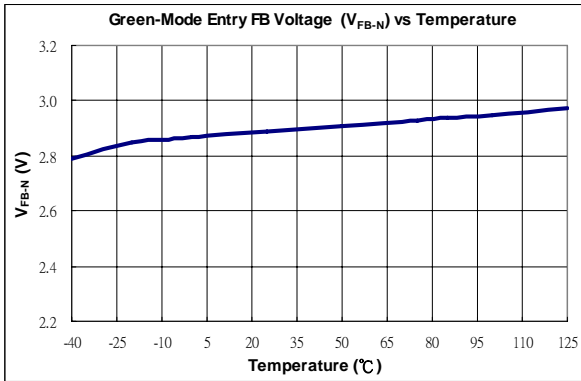

**Low Cost Green-Mode PWM Controller for Flyback Converters**
**SG6859**

## OPERATION DESCRIPTION

SG6859 devices integrate many useful designs into one controller for low-power switch-mode power supplies. The following descriptions highlight some of the features of the SG6859 series.

### Start-up Current

The start-up current is only 9uA. Low start-up current allows a start-up resistor with a high resistance and a low-wattage to supply the start-up power for the controller. A 1.5 MΩ, 0.25W, start-up resistor and a 10uF/25V V<sub>DD</sub> hold-up capacitor would be sufficient for an AC-to-DC power adapter with a wide input range (100V<sub>AC</sub> to 240V<sub>AC</sub>).

### Operating Current

The operating current has been reduced to 3mA. The low operating current results in higher efficiency and reduces the V<sub>DD</sub> hold-up capacitance requirement.

### Green-Mode Operation

The proprietary green-mode function provides off-time modulation to linearly decrease the switching frequency under light-load conditions. On-time is limited to provide stronger protection against brownouts and other abnormal conditions. The feedback current, which is sampled from the voltage feedback loop, is taken as the reference. Once the feedback current exceeds the threshold current, the switching frequency starts to decrease. This green-mode function dramatically reduces power consumption under light-load and zero-load conditions. Power supplies using the SG6859 can easily meet even the strictest regulations regarding standby power consumption.

### Oscillator Operation

A resistor connected from the RI pin to ground will generate a constant current source for the SG6859. This current is used to charge an internal capacitor. The charge-time determines the internal clock speed and the switching frequency. Increasing the resistance will reduce the amplitude of the input current and reduce the switching frequency. A 95kΩ resistor R<sub>i</sub> results in a 50uA constant current I<sub>i</sub> and a 70kHz switching frequency. The relationship between R<sub>i</sub> and the switching frequency is:

$$f_{PWM} = \frac{6650}{R_i \text{ (k}\Omega\text{)}} \text{ (kHz)}$$

### Leading-Edge Blanking

Each time the power MOSFET is switched on, a turn-on spike will inevitably occur at the sense-resistor. To avoid premature termination of the switching pulse, a 320nsec leading edge blanking time is built in. Conventional RC filtering can therefore be omitted. During this blanking period, the current-limit comparator is disabled and it cannot switch off the gate driver.

### Constant Output Power Limit

When the SENSE voltage across the sense resistor R<sub>s</sub> reaches the threshold voltage (around 0.96V), the output GATE drive will be turned off following a short propagation delay t<sub>PD</sub>.

This propagation delay will introduce an additional current proportional to t<sub>PD</sub>\*V<sub>in</sub>/L<sub>p</sub>. The propagation delay is nearly constant regardless of the input line voltage V<sub>IN</sub>. Higher input line voltages will result in larger additional currents. At high input line voltages, the output power limit will be higher than at low input line voltages.

To compensate for this output power limit variation across a wide AC input range, the threshold voltage is adjusted by adding a positive ramp.

This ramp signal rises from 0.80V to 0.96V, and then flattens out at 0.96V. A smaller threshold voltage forces the output GATE drive to terminate earlier.

This reduces the total PWM turn-on time and makes the output power equal to that of low line input. This proprietary internal compensation ensures a constant output power limit for a wide AC input voltage range (90VAC to 264VAC).

### Under Voltage Lockout (UVLO)

The turn-on and turn-off thresholds of the SG6859 are fixed internally at 16.5V/11.5V. During start-up, the hold-up capacitor must be charged to 16.5V through the start-up resistor, so that the SG6859 will be enabled. The hold-up capacitor will continue to supply V<sub>DD</sub> until power can be delivered from the auxiliary winding of the main transformer. V<sub>DD</sub> must not drop below 11.5V during this start-up process. This UVLO hysteresis window ensures that hold-up capacitor will be adequate to supply V<sub>DD</sub> during start-up.



## Gate Output

The SG6859 BiCMOS output stage is a fast totem pole gate driver. Cross conduction has been avoided to minimize heat dissipation, increase efficiency, and enhance reliability. The output driver is clamped by an internal 17V Zener diode in order to protect power MOSFET transistors against undesired over-voltage gate signals.

## Built-in Slope Compensation

The sensed voltage across the current sense resistor is used for current mode control and pulse-by-pulse current limiting. Built-in slope compensation will improve stability and prevent sub-harmonic oscillations due to peak-current mode control. The SG6859 has a synchronized, positively-sloped ramp built-in at each switching cycle. The slope of the ramp is:

$$\frac{0.36 \times Duty}{Duty(max.)}$$

## Noise Immunity

Noise from the current sense or the control signal can cause significant pulse width jitter, particularly in continuous-conduction mode. While slope compensation helps alleviate these problems, further precautions should still be taken. Good placement and layout practices should be followed. Avoiding long PCB traces and component leads, locating compensation and filter components near the SG6859, and increasing the power MOS gate resistance is advised.

Low Cost Green-Mode PWM Controller for Flyback Converters

SG6859

REFERENCE CIRCUIT

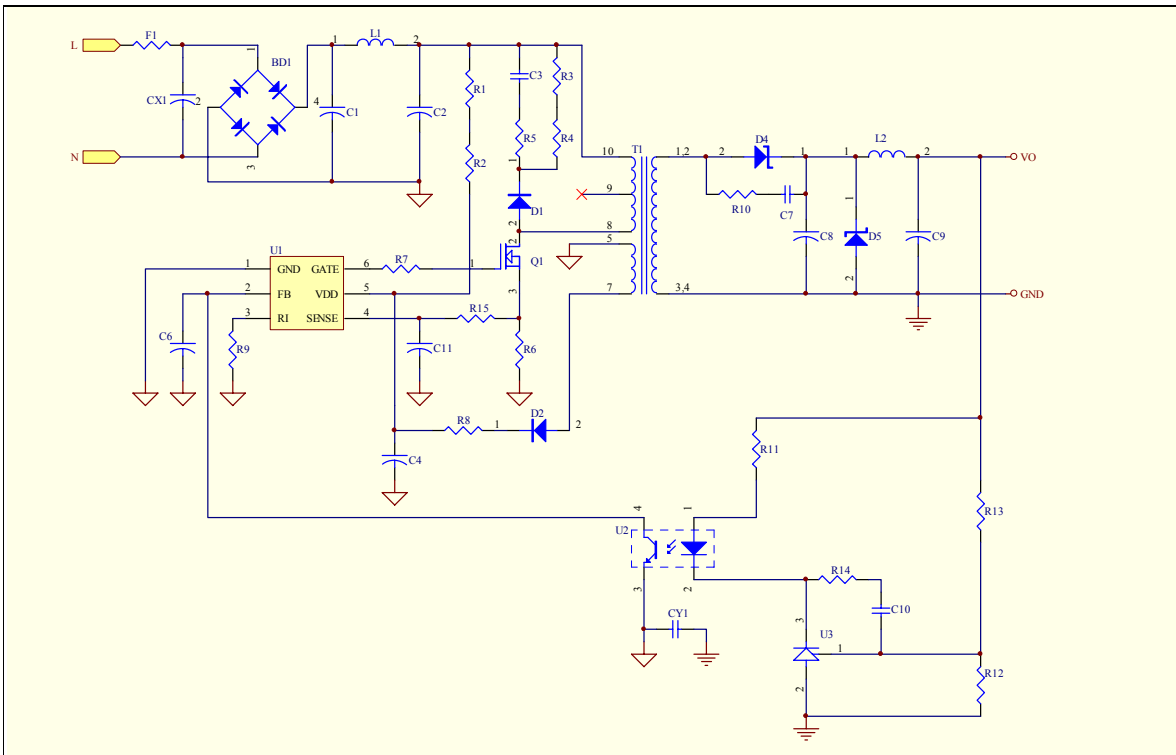

BOM

Reference	Component	Reference	Component
BD1	BD 1A/500V	L2	10uH 6mm
CX1 (Optional)	XC 0.1uF	Q1	MOSFET 1A/600V
CY1 (Optional)	YC 102P/400V (Y1)	R1,R2	R 750KΩ 1206
C1	CC 103P/500V	R3,R4	R 47KΩ 1206
C2	EC 10μF/400V 105°C	R5	R 47Ω 1206
C3	CC 102P/500V	R6	R 4.7Ω 1206
C4	EC 10μ/50V	R7	R 100Ω 0805
C6	CC 472P 0805	R8	R 10Ω 1206
C7 (Optional)	CC 102P/100V 1206	R9	R 100KΩ 0805
C8	EC 470μ/10V 105°C	R10 (Optional)	R 10Ω 1206
C9	EC 220μ/10V 105°C	R11	R 100Ω 1/8W
C10	CC 222P 0805	R12	R 33KΩ 0805
C11	N.C.	R13	R 33KΩ 1/8W
D1	Diode FRI07	R14	R 4.7KΩ 0805
D2	Diode FR102	R15	R 0Ω 0805
D4	Diode SB360	T1	EE-16
D5 (Optional)	ZD 6.8V 0.5W	U1	IC SG6859
F1	R 1Ω/0.5W	U2	PC817
L1	20mH 6*8mm	U3	TL431

**PACKAGE INFORMATION**

**8 PINS - DIP (D)**

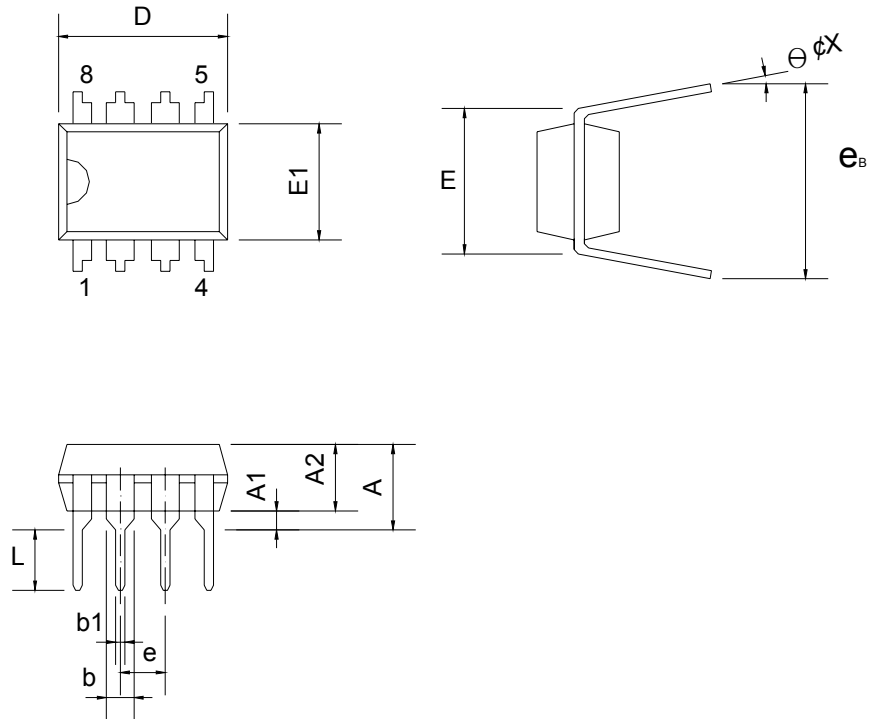

**Dimensions**

Symbol	Millimeters			Inches		
	Min.	Typ.	Max.	Min.	Typ.	Max.
A			5.334			0.210
A1	0.381			0.015		
A2	3.175	3.302	3.429	0.125	0.130	0.135
b		1.524			0.060	
b1		0.457			0.018	
D	9.017	9.271	10.160	0.355	0.365	0.400
E		7.620			0.300	
E1	6.223	6.350	6.477	0.245	0.250	0.255
e		2.540			0.100	
L	2.921	3.302	3.810	0.115	0.130	0.150
e <sub>B</sub>	8.509	9.017	9.525	0.335	0.355	0.375
θ°	0°	7°	15°	0°	7°	15°

6 PINS - SOT (T)

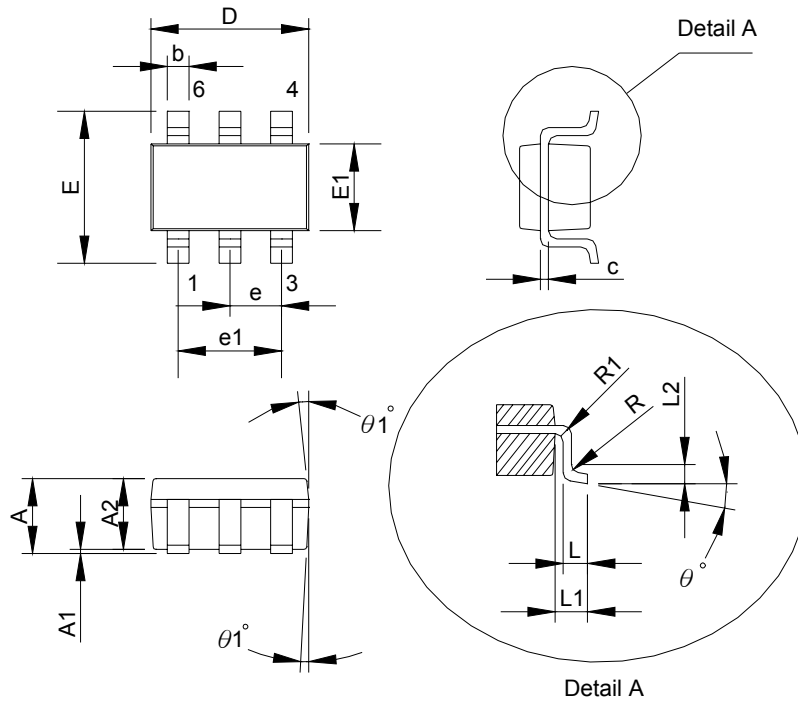

Dimensions

Symbol	Millimeters			Inches		
	Min.	Typ.	Max.	Min.	Typ.	Max.
A			1.45			0.057
A1			0.15			0.006
A2	0.90	1.15	1.30	0.036	0.045	0.051
b	0.30		0.50	0.011		0.020
c	0.08		0.22	0.003		0.009
D		2.90			0.114	
E		2.80			0.110	
E1		1.60			0.063	
e		0.95			0.037	
e1		1.90			0.075	
L	0.30	0.45	0.60	0.020	0.018	0.024
L1		0.60			0.024	
L2		0.25			0.010	
R	0.10			0.004		
R1	0.10		0.25	0.004		0.010
$\theta^\circ$	0°	4°	8°	0°	4°	8°
$\theta_1^\circ$	5°	10°	15°	5°	10°	15°

Low Cost Green-Mode PWM Controller for Flyback Converters

SG6859



**TRADEMARKS**

The following are registered and unregistered trademarks and service marks Fairchild Semiconductor owns or is authorized to use and is not intended to be an exhaustive list of all such trademarks.

ACEx <sup>®</sup>	Green FPS <sup>™</sup>	Power247 <sup>®</sup>	SuperSOT <sup>™</sup> -8
Build it Now <sup>™</sup>	Green FPS <sup>™</sup> e-Series <sup>™</sup>	POWEREDGE <sup>®</sup>	SyncFET <sup>™</sup>
CorePLUS <sup>™</sup>	GTO <sup>™</sup>	Power-SPM <sup>™</sup>	The Power Franchise <sup>®</sup>
CROSSVOLT <sup>™</sup>	i-Lo <sup>™</sup>	PowerTrench <sup>®</sup>	<b>the Power Franchise</b>
CTL <sup>™</sup>	IntelliMAX <sup>™</sup>	Programmable Active Droop <sup>™</sup>	TinyBoost <sup>™</sup>
Current Transfer Logic <sup>™</sup>	ISOPLANAR <sup>™</sup>	QFET <sup>®</sup>	TinyBuck <sup>™</sup>
EcoSPARK <sup>®</sup>	MegaBuck <sup>™</sup>	QS <sup>™</sup>	TinyLogic <sup>®</sup>
<b>F</b> <sup>®</sup>	MICROCOUPLER <sup>™</sup>	QT Optoelectronics <sup>™</sup>	TINYOPTO <sup>™</sup>
Fairchild <sup>®</sup>	MicroFET <sup>™</sup>	Quiet Series <sup>™</sup>	TinyPower <sup>™</sup>
Fairchild Semiconductor <sup>®</sup>	MicroPak <sup>™</sup>	RapidConfigure <sup>™</sup>	TinyPWM <sup>™</sup>
FACT Quiet Series <sup>™</sup>	MillerDrive <sup>™</sup>	SMART START <sup>™</sup>	TinyWire <sup>™</sup>
FACT <sup>®</sup>	Motion-SPM <sup>™</sup>	SPM <sup>®</sup>	μSerDes <sup>™</sup>
FAST <sup>®</sup>	OPTOLOGIC <sup>®</sup>	STEALTH <sup>™</sup>	UHC <sup>®</sup>
FastvCore <sup>™</sup>	OPTOPLANAR <sup>®</sup>	SuperFET <sup>™</sup>	UniFET <sup>™</sup>
FPS <sup>™</sup>	 <sup>®</sup>	SuperSOT <sup>™</sup> -3	VCX <sup>™</sup>
FRFET <sup>®</sup>	PDP-SPM <sup>™</sup>	SuperSOT <sup>™</sup> -6	
Global Power Resource <sup>SM</sup>	Power220 <sup>®</sup>		

**DISCLAIMER**

FAIRCHILD SEMICONDUCTOR RESERVES THE RIGHT TO MAKE CHANGES WITHOUT FURTHER NOTICE TO ANY PRODUCTS HEREIN TO IMPROVE RELIABILITY, FUNCTION, OR DESIGN. FAIRCHILD DOES NOT ASSUME ANY LIABILITY ARISING OUT OF THE APPLICATION OR USE OF ANY PRODUCT OR CIRCUIT DESCRIBED HEREIN; NEITHER DOES IT CONVEY ANY LICENSE UNDER ITS PATENT RIGHTS, NOR THE RIGHTS OF OTHERS. THESE SPECIFICATIONS DO NOT EXPAND THE TERMS OF FAIRCHILD'S WORLDWIDE TERMS AND CONDITIONS, SPECIFICALLY THE WARRANTY THEREIN, WHICH COVERS THESE PRODUCTS.

**LIFE SUPPORT POLICY**

FAIRCHILD'S PRODUCTS ARE NOT AUTHORIZED FOR USE AS CRITICAL COMPONENTS IN LIFE SUPPORT DEVICES OR SYSTEMS WITHOUT THE EXPRESS WRITTEN APPROVAL OF FAIRCHILD SEMICONDUCTOR CORPORATION.

As used herein:

1. Life support devices or systems are devices or systems which, (a) are intended for surgical implant into the body or (b) support or sustain life, and (c) whose failure to perform when properly used in accordance with instructions for use provided in the labeling, can be reasonably expected to result in a significant injury of the user.
2. A critical component in any component of a life support, device, or system whose failure to perform can be reasonably expected to cause the failure of the life support device or system, or to affect its safety or effectiveness.

**PRODUCT STATUS DEFINITIONS**

**Definition of Terms**

Datasheet Identification	Product Status	Definition
Advance Information	Formative or In Design	This datasheet contains the design specifications for product development. Specifications may change in any manner without notice.
Preliminary	First Production	This datasheet contains preliminary data; supplementary data will be published at a later date. Fairchild Semiconductor reserves the right to make changes at any time without notice to improve design.
No Identification Needed	Full Production	This datasheet contains final specifications. Fairchild Semiconductor reserves the right to make changes at any time without notice to improve design.
Obsolete	Not In Production	This datasheet contains specifications on a product that has been discontinued by Fairchild Semiconductor. The datasheet is printed for reference information only.

Rev. 131

ON Semiconductor and  are trademarks of Semiconductor Components Industries, LLC dba ON Semiconductor or its subsidiaries in the United States and/or other countries. ON Semiconductor owns the rights to a number of patents, trademarks, copyrights, trade secrets, and other intellectual property. A listing of ON Semiconductor's product/patent coverage may be accessed at [www.onsemi.com/site/pdf/Patent-Marking.pdf](http://www.onsemi.com/site/pdf/Patent-Marking.pdf). ON Semiconductor reserves the right to make changes without further notice to any products herein. ON Semiconductor makes no warranty, representation or guarantee regarding the suitability of its products for any particular purpose, nor does ON Semiconductor assume any liability arising out of the application or use of any product or circuit, and specifically disclaims any and all liability, including without limitation special, consequential or incidental damages. Buyer is responsible for its products and applications using ON Semiconductor products, including compliance with all laws, regulations and safety requirements or standards, regardless of any support or applications information provided by ON Semiconductor. "Typical" parameters which may be provided in ON Semiconductor data sheets and/or specifications can and do vary in different applications and actual performance may vary over time. All operating parameters, including "Typicals" must be validated for each customer application by customer's technical experts. ON Semiconductor does not convey any license under its patent rights nor the rights of others. ON Semiconductor products are not designed, intended, or authorized for use as a critical component in life support systems or any FDA Class 3 medical devices or medical devices with a same or similar classification in a foreign jurisdiction or any devices intended for implantation in the human body. Should Buyer purchase or use ON Semiconductor products for any such unintended or unauthorized application, Buyer shall indemnify and hold ON Semiconductor and its officers, employees, subsidiaries, affiliates, and distributors harmless against all claims, costs, damages, and expenses, and reasonable attorney fees arising out of, directly or indirectly, any claim of personal injury or death associated with such unintended or unauthorized use, even if such claim alleges that ON Semiconductor was negligent regarding the design or manufacture of the part. ON Semiconductor is an Equal Opportunity/Affirmative Action Employer. This literature is subject to all applicable copyright laws and is not for resale in any manner.

## PUBLICATION ORDERING INFORMATION

### LITERATURE FULFILLMENT:

Email Requests to: [orderlit@onsemi.com](mailto:orderlit@onsemi.com)

ON Semiconductor Website: [www.onsemi.com](http://www.onsemi.com)

### TECHNICAL SUPPORT

North American Technical Support:  
Voice Mail: 1 800-282-9855 Toll Free USA/Canada  
Phone: 011 421 33 790 2910

Europe, Middle East and Africa Technical Support:

Phone: 00421 33 790 2910

For additional information, please contact your local Sales Representative