

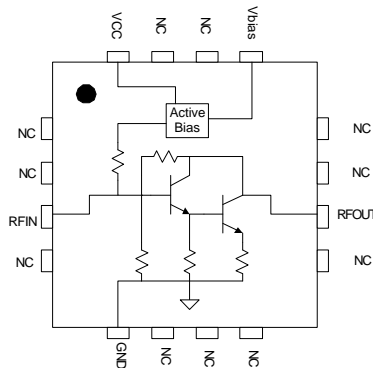

Product Description

Sirenza Microdevices' SGB-6533 is a high performance SiGe HBT MMIC amplifier utilizing a Darlington configuration with an active bias network. The active bias network provides stable current over temperature and process Beta variations. Designed to run directly from a 5V supply the SGB-6533 does not require a drop resistor as compared to typical Darlington amplifiers. This robust amplifier features a Class 1C ESD rating, low thermal resistance, and unconditional stability. The SGB-6533 product is designed for high linearity 5V gain block applications that require small size and minimal external components. It is on chip matched to 50 ohm and an external bias inductor choke is required for the application band.

Functional Block Diagram



Key Specifications

Symbol	Parameters: Test Conditions $Z_0 = 50\Omega, V_{CC} = 5.0V, I_c = 88mA, T = 30^\circ C$	Unit	Min.	Typ.	Max.
f_o	Frequency of Operation	MHz	DC		3000
S_{21}	Small Signal Gain – 850MHz	dB		25.0	
	Small Signal Gain – 1950MHz		17.0	18.5	20.0
	Small Signal Gain – 2400MHz			17.0	
P_{1dB}	Output Power at 1dB Compression – 850MHz	dBm		19.0	
	Output Power at 1dB Compression – 1950MHz		17.0	18.5	
	Output Power at 1dB Compression – 2400MHz			18.0	
OIP3	Output IP3 – 850MHz	dB		32.0	
	Output IP3 – 1950MHz		30.0	32.0	
	Output IP3 – 2400MHz			32.0	
IRL	Input Return Loss @ 1950MHz	dB	11.0	15.0	
ORL	Output Return Loss @ 1950MHz	dB	10.0	14.0	
I_c	Current	mA	76	88	98
NF	Noise Figure @ 1950MHz	dB		3.7	4.7
$R_{th, j-l}$	Thermal Resistance (junction - lead)	$^\circ C/W$		60	

The information provided herein is believed to be reliable at press time. Sirenza Microdevices assumes no responsibility for inaccuracies or omissions. Sirenza Microdevices assumes no responsibility for the use of this information, and all such information shall be entirely at the user's own risk. Prices and specifications are subject to change without notice. No patent rights or licenses to any of the circuits described herein are implied or granted to any third party. Sirenza Microdevices does not authorize or warrant any Sirenza Microdevices product for use in life-support devices and/or systems.

Copyright 2002 Sirenza Microdevices, Inc. All worldwide rights reserved.
303 South Technology Court, Broomfield, CO 80021

Phone: (800) SMI-MMIC

<http://www.sirenza.com>
EDS-103099 Rev E

SGB-6533

DC – 3 GHz Active Bias Gain Block



Product Features

- High reliability SiGe HBT Technology
- Robust Class 1C ESD
- Simple and small size
- $P_{1dB} = 18.5 \text{ dBm @ } 1950\text{MHz}$
- $IP3 = 32 \text{ dBm @ } 1950\text{MHz}$
- Low Thermal Resistance = 60 C/W

Applications

- 5V applications
- LO buffer amp
- RF pre-driver and RF receive path



SGB-6533 DC-3GHz Active Bias Gain Block

Detailed Performance Table: Vcc=5V, Ic=88mA, T=25C, Z=50ohms

Symbol	Parameter	Units	100MHz	500MHz	850MHz	1950MHz	2400MHz	3500MHz
G	Small Signal Gain	dB	28.4	26.9	25.0	18.5	17.0	13.1
OIP3	Output 3rd Order Intercept Point	dBm		32.0	32.0	32.0	32.0	
P1dB	Output Power at 1dB Compression	dBm		19.1	19.0	18.5	18.0	
IRL	Input Return Loss	dB	15.1	19.1	26.4	15.0	13.5	8.7
ORL	Output Return Loss	dB	21.4	18.5	15.3	14.0	11.9	13.6
S12	Reverse Isolation	dB	30.8	30.3	29.7	26.2	25.4	22.9
NF	Noise Figure	dB	4.6	3.1	3.1	3.7	4.2	4.9

Pin Out Description

Pin #	Function	Description
1,2,4,6,7,8,11,12,14	NC	These are no connect pins. Leave them unconnected on the PC board.
3	RFIN	RF input pin. A DC voltage should not be connected externally to this pin
5	GND	An extra ground pin that is connected to the backside exposed paddle. Connection is optional.
10	RFOUT	RF Output pin. Bias is applied to the Darlington stage thru this pin.
13	VBIAS	This pin sources the current from the active bias circuit. Connect to pin 10 thru an inductor choke.
16	VCC	This is Vcc for the active bias circuit.
Back-side	GND	The backside exposed paddle is the main electrical GND and requires multiple vias in the PC board to GND. It is also the main thermal path.

Simplified Device Schematic

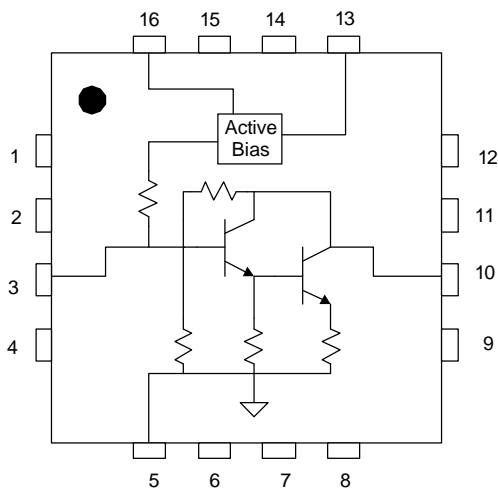

Caution: ESD Sensitive

Appropriate precaution in handling, packaging and testing devices must be observed.

Absolute Maximum Ratings

Parameters	Value	Unit
Current (Ic total)	150	mA
Device Voltage (V _D)	6.5	V
Power Dissipation	0.75	W
Operating Lead Temperature (T _L)	-40 to +85	°C
RF Input Power, Zload = 50 ohm	15	dBm
RF Input Power, Zload > 10:1 VSWR	7	dBm
Storage Temperature Range	-40 to +150	°C
Operating Junction Temperature (T _J)	+150	°C

Operation of this device beyond any one of these limits may cause permanent damage. For reliable continuous operation the device voltage and current must not exceed the maximum operating values specified in the table on page one.

Bias conditions should also satisfy the following expression:
 $I_D V_D < (T_J - T_L) / R_{TH} \cdot j$



SGB-6533 DC-3GHz Active Bias Gain Block

Evaluation Board Data ($V_{CC}=V_{BIAS} = 5.0V$, $I_C = 88mA$) Bias Tee is substituted for DC feed inductor (L1)

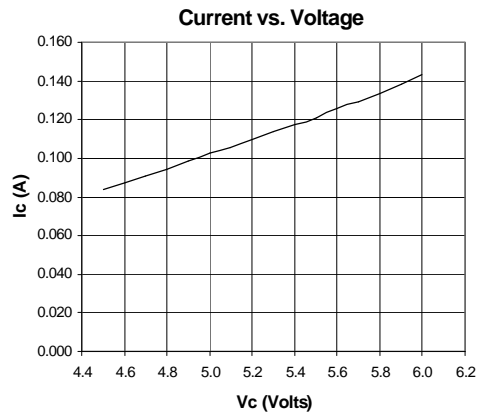
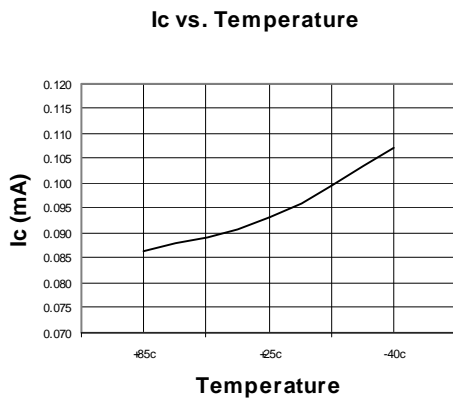
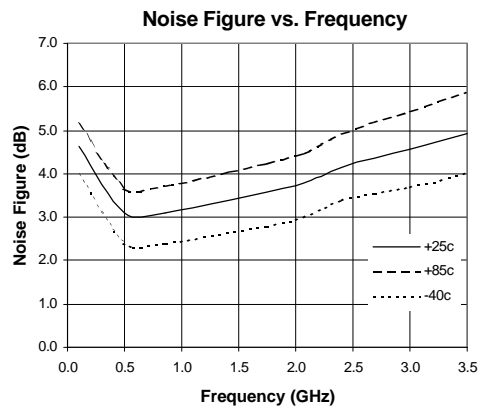
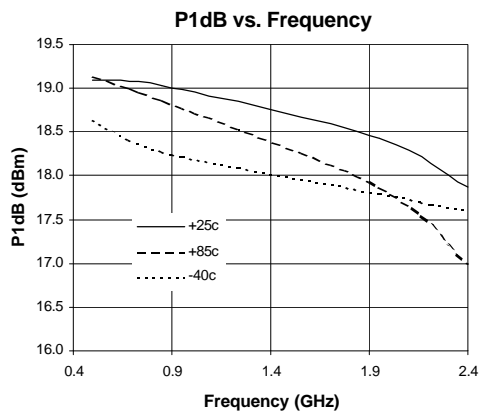
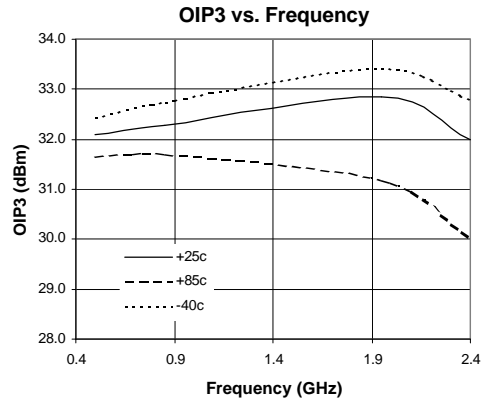
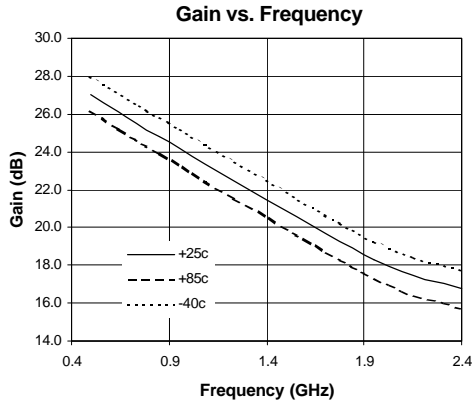



SGB-6533 DC-3GHz Active Bias Gain Block

Evaluation Board Data ($V_{CC}=V_{BIAS} = 5.0V$, $I_C = 88mA$) Bias Tee is substituted for DC feed inductor (L1)

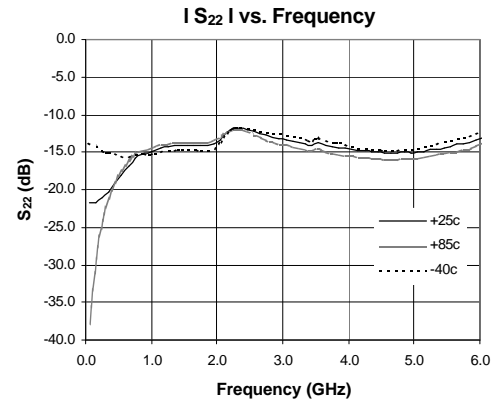
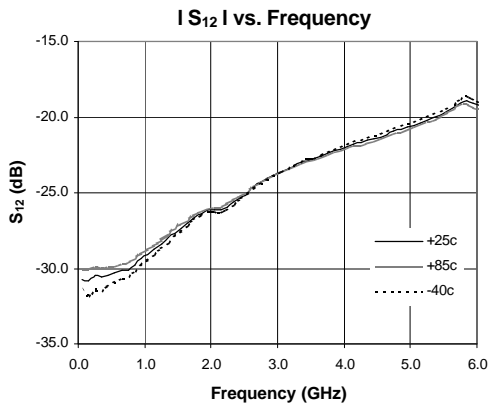
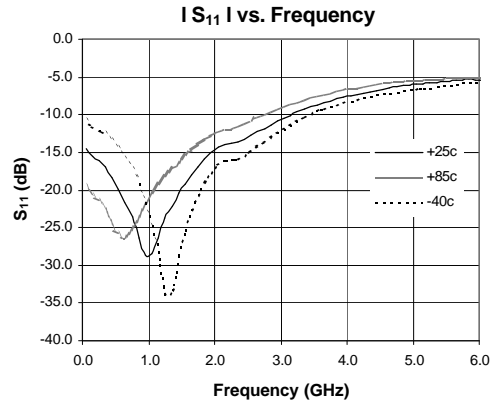
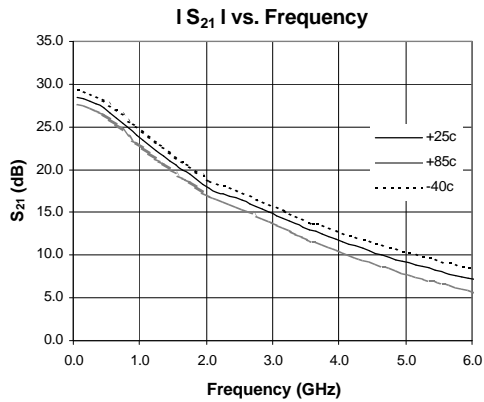

Typical Evaluation Board Schematic for 5.0V

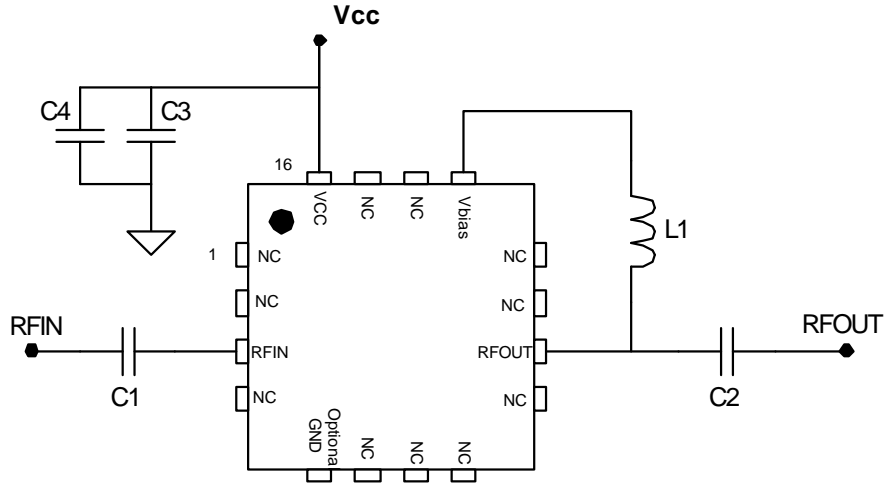

Evaluation Board - Board material GETEK, 31mil thick, Dk=4.2, 1 oz. copper

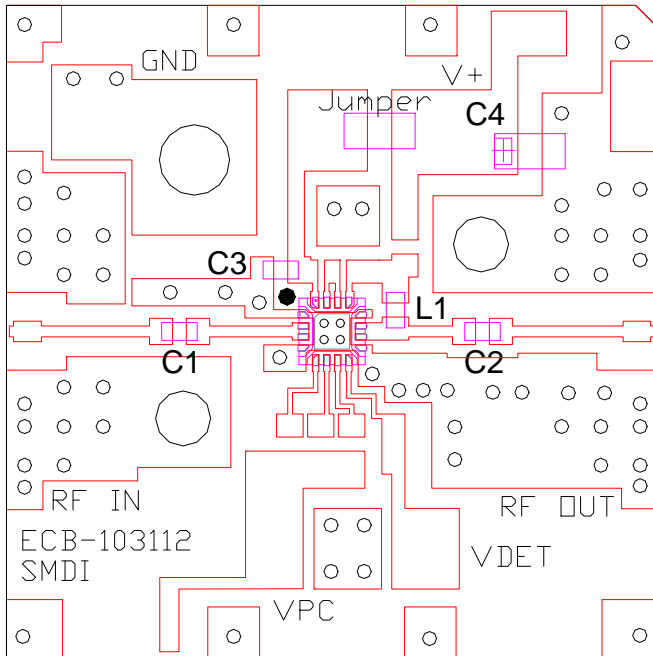

Component Values By Band

Designator	500MHz	850MHz	1950MHz	2400MHz
C3	1000pF	1000pF	1000pF	1000pF
C4*	1uF	1uF	1uF	1uF
C1, C2	220pF	68pF	43pF	22pF
L1	68 nH	33nH	22nH	18nH

* C4 is optional depending on application and filtering. Not required for SGB device operation.

Note: The amplifier can be run from a 8V supply by simply inserting a 33 ohm resistor in series with Vcc.



SGB-6533 DC-3GHz Active Bias Gain Block

Part Number Ordering Information

Part Number	Reel Size	Devices/Reel
SGB-6533	13"	3000

Part Marking

The part will be symbolized with an "SGB-6533" marking designator on the top surface of the package.

Package Outline Drawing (Dimensions in mm)

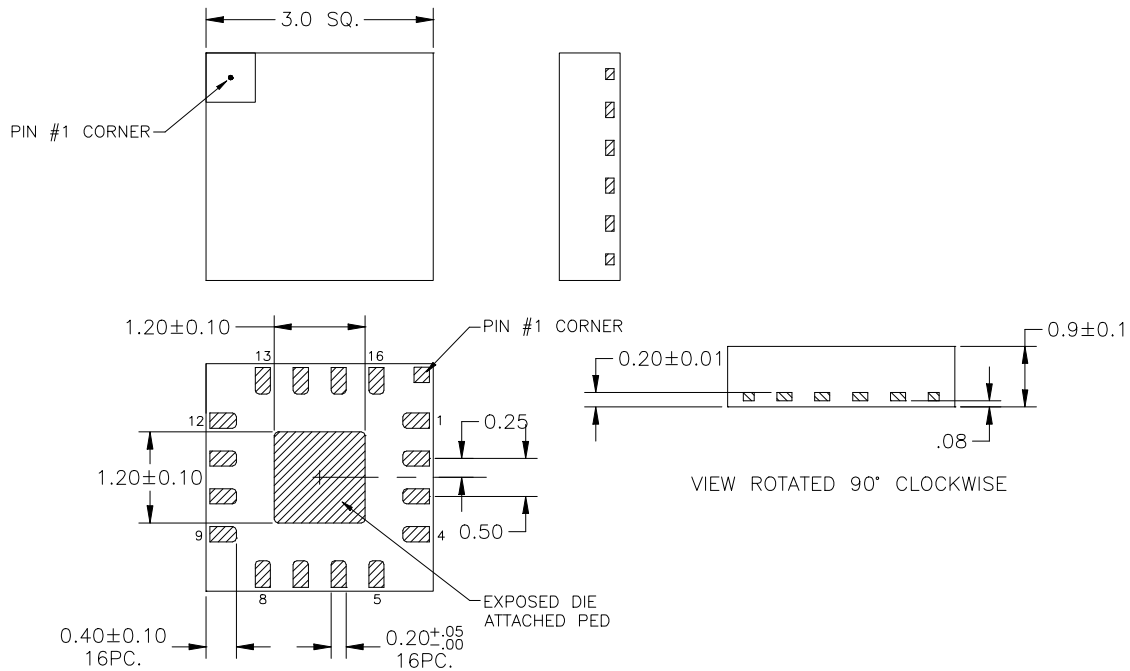

Recommended Land Pattern (dimensions in mm[in].):

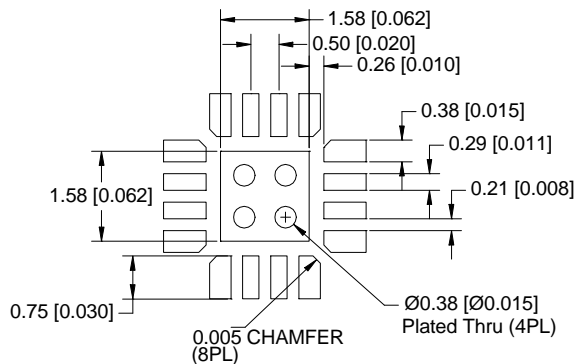

Recommended PCB Soldermask (SMOBC) for Land Pattern (dimensions in mm[in].):

