



SGM3803

90% Efficient Synchronous Step-Up Converter with 200mA Negative Charge Pump Inverter

GENERAL DESCRIPTION

The SGM3803 is a constant frequency, current mode, synchronous step-up switching regulator with 200mA negative charge pump inverter which generates an unregulated negative output voltage from an input voltage ranging from 1.4V to 5.5V. The device is typically used to generate +5V and -5V from battery.

High switching frequency minimizes the sizes of inductor and capacitor. Only three external capacitors are required to build a complete charge pump inverter. Integrated power MOSFETs and internal compensation of boost DC/DC make the SGM3803 simple to use and fit the total solution into a compact space.

The negative charge pump in SGM3803 can deliver a maximum output current of 200mA with a typical conversion efficiency of greater than 80% over a wide output current range.

For light load current, the SGM3803 boost DC/DC enters into the power-save mode to maintain high efficiency. Anti-ringing control circuitry reduces EMI concerns by damping the inductor in discontinuous mode. The SGM3803 boost DC/DC provides true output disconnect and this allows V_{OUT1} to go to zero volt during shutdown without drawing any current from the input source. The SGM3803 supports 1.8V logic for control.

The output voltage of SGM3803 boost DC/DC can be programmed by an external resistor divider. Boost DC/DC and negative charge pump inverter have independent enable control.

The device is available in TDFN-3x3-12L package. It operates over an ambient temperature range of -40°C to +85°C.

FEATURES

Boost DC/DC

- 90% Efficient Synchronous Boost Converter
- Device Quiescent Current: 30µA (TYP)
- Less than 1µA Shutdown Current
- Input Voltage Range: 2.7V to 5.5V
- Output Voltage Clamping: 6V
- Adjustable Output Voltage Up to 5.5V
- Power-Save Mode for Improved Efficiency at Low Output Power
- Load Disconnect During Shutdown
- Low Reverse Leakage Current when $V_{OUT1} > V_{CC}$
- 1.8V Logic on EN1 Pin for Control
- Over-Temperature Protection

Negative Charge Pump Inverter

- Up to 200mA Output Current
- Only Three Small 2.2µF to 4.7µF Ceramic Capacitors Needed
- Input Voltage Range: 1.4V to 5.5V
- Low 1.5mA (TYP) Quiescent Current in Active Status
- 950kHz Switching Frequency
- 1.8V Logic on EN2 Pin for Control
- Integrated Active Schottky-Diode for Start-Up into Load

APPLICATIONS

Single-Cell Li Battery Powered Products

Portable Audio Players

Cellular Phones

Personal Medical Products

PACKAGE/ORDERING INFORMATION

MODEL	PACKAGE DESCRIPTION	SPECIFIED TEMPERATURE RANGE	ORDERING NUMBER	PACKAGE MARKING	PACKING OPTION
SGM3803	TDFN-3x3-12L	-40°C to +85°C	SGM3803YTDF12G/TR	SGM 3803DF XXXXX	Tape and Reel, 3000

MARKING INFORMATION

NOTE: XXXXX = Date Code and Vendor Code.

XXXXX

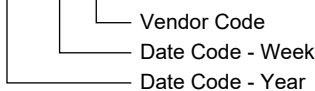

Green (RoHS & HSF): SG Micro Corp defines "Green" to mean Pb-Free (RoHS compatible) and free of halogen substances. If you have additional comments or questions, please contact your SGMICRO representative directly.

ABSOLUTE MAXIMUM RATINGS

Input Voltage Range on SW, OUT1, VCC, FB, EN1, EN2, IN	-0.3V to 6V
OUT2	-6V to 0.3V
C _{FLY-}	0.3V to V _{OUT2} - 0.3V
C _{FLY+}	-0.3V to V _{IN} + 0.3V
Junction Temperature	+150°C
Storage Temperature Range	-65°C to +150°C
Lead Temperature (Soldering, 10s)	+260°C
ESD Susceptibility	
HBM	4000V
MM	200V

RECOMMENDED OPERATING CONDITIONS

Operating Temperature Range	-40°C to +85°C
-----------------------------	----------------

OVERSTRESS CAUTION

Stresses beyond those listed in Absolute Maximum Ratings may cause permanent damage to the device. Exposure to absolute maximum rating conditions for extended periods may affect reliability. Functional operation of the device at any conditions beyond those indicated in the Recommended Operating Conditions section is not implied.

ESD SENSITIVITY CAUTION

This integrated circuit can be damaged if ESD protections are not considered carefully. SGMICRO recommends that all integrated circuits be handled with appropriate precautions. Failure to observe proper handling and installation procedures can cause damage. ESD damage can range from subtle performance degradation to complete device failure. Precision integrated circuits may be more susceptible to damage because even small parametric changes could cause the device not to meet the published specifications.

DISCLAIMER

SG Micro Corp reserves the right to make any change in circuit design, or specifications without prior notice.

PIN CONFIGURATION

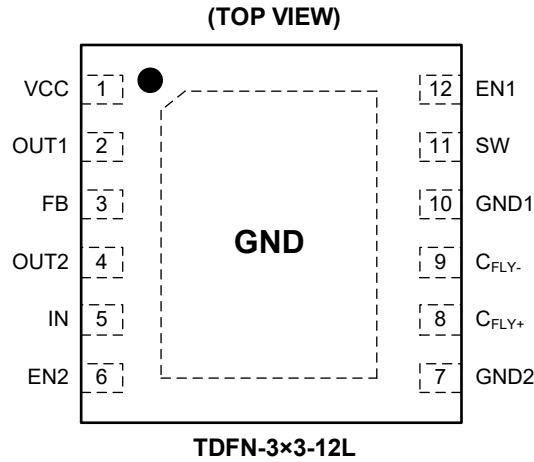

PIN DESCRIPTION

PIN	NAME	FUNCTION
1	VCC	Boost Converter Supply Voltage.
2	OUT1	Boost Converter Output.
3	FB	Boost Converter Output Voltage Feedback Pin. Voltage feedback for programming the output voltage.
4	OUT2	Charge Pump Inverter Power Output with $V_{OUT2} = -V_{IN}$.
5	IN	Charge Pump Inverter Supply Input. Connect to an input supply in the 1.4V to 5.5V range.
6	EN2	Charge Pump Inverter Enable Control. When EN2 = "High", charge pump is in active mode. When EN2 = "Low", charge pump is in shutdown mode.
7	GND2	Ground of Charge Pump Inverter.
8	C _{FLY+}	Charge Pump Inverter Positive Terminal of the Flying Capacitor C _{FLY} .
9	C _{FLY-}	Charge Pump Inverter Negative Terminal of the Flying Capacitor C _{FLY} .
10	GND1	Ground of Boost DC/DC.
11	SW	Boost and Rectifying Switch Input.
12	EN1	Boost Converter Enable Input. When EN1 = "High", boost converter is in active mode. When EN1 = "Low", boost converter is in shutdown mode.

ELECTRICAL CHARACTERISTICS**Boost DC/DC**(Full = -40°C to +85°C, typical values are at $T_A = +25^\circ\text{C}$, unless otherwise noted.)

PARAMETER	SYMBOL	CONDITIONS	TEMP	MIN	TYP	MAX	UNITS
DC/DC Stage							
Output Voltage Range	V_{OUT1}		Full	3		5.5	V
Input Voltage Range	V_{CC}		+25°C	2.7		5.5	V
Feedback Voltage	V_{FB}		Full	487	500	516	mV
Oscillator Frequency	f_1		Full	940	1200	1460	kHz
Switch Current Limit	I_{SW}		Full	0.85	1.1	1.35	A
Start-Up Current Limit			+25°C		300		mA
Boost Switch-On Resistance		$V_{OUT1} = 5V$	+25°C		400		mΩ
Rectifying Switch-On Resistance		$V_{OUT1} = 5V$	+25°C		530		mΩ
Line Regulation		$V_{CC} = 2.7V$ to $V_{OUT1} - 0.5V$, $I_{OUT1} = 0mA$	Full		0.5	1	%
Load Regulation			+25°C		0.5		%
Quiescent Current	V_{CC}	$V_{EN1} = V_{CC} = 2.7V$, $I_{OUT1} = 0mA$	Full		0.1	1	μA
	V_{OUT}	$V_{EN1} = V_{CC} = 2.7V$, $I_{OUT1} = 0mA$, $V_{OUT1} = 5V$	+25°C		30	65	
Shutdown Current		$V_{EN1} = 0V$, $V_{CC} = 2.7V$	+25°C			1	μA
Control Stage							
EN1 Input Low Voltage	V_{IL1}		Full			0.4	V
EN1 Input High Voltage	V_{IH1}		Full	1.6			V
EN1 Input Current		Clamped on GND or VCC	Full			1	μA
Over-Temperature Protection					150		°C
Over-Temperature Hysteresis					20		°C

Negative Charge Pump Inverter(C_{IN2} = C_{FLY} = C_{OUT2} = 3.3μF, V_{IN} = 5V, Full = -40°C to +85°C. Typical values are at $T_A = +25^\circ\text{C}$, unless otherwise noted.)

PARAMETER	SYMBOL	CONDITIONS	TEMP	MIN	TYP	MAX	UNITS
Charge Pump Stage							
Input Voltage Range	V_{IN}	$R_L = 5k\Omega$	Full	1.4		5.5	V
Maximum Output Current Range at OUT2	I_{OUT2}		Full	200			mA
Output Voltage	V_{OUT2}		+25°C		$-V_{IN}$		V
Output Voltage Ripple	V_{PP}	$I_{OUT2} = 100mA$, $C_{FLY} = C_{OUT2} = 3.3\mu F$	+25°C		20		mV _{P-P}
Quiescent Current (No Load Input Current)	I_Q		+25°C		1.5	1.85	mA
			Full			1.9	
		Shutdown mode	+25°C		0.4	1	μA
			Full			2	
Oscillator Frequency	f_2		+25°C	800	950	1100	kHz
			Full	750		1150	
Impedance		$I_{OUT2} = 30mA$	+25°C		4.2	7.5	Ω
			Full			8	
Control Stage							
EN2 Input High Voltage	V_{IH2}		Full	1.5			V
EN2 Input Low Voltage	V_{IL2}		Full			0.4	V

TYPICAL PERFORMANCE CHARACTERISTICS

All the curves are measured with typical application, and load current I_{OUT} is between V_{OUT1} and V_{OUT2} , unless otherwise noted.

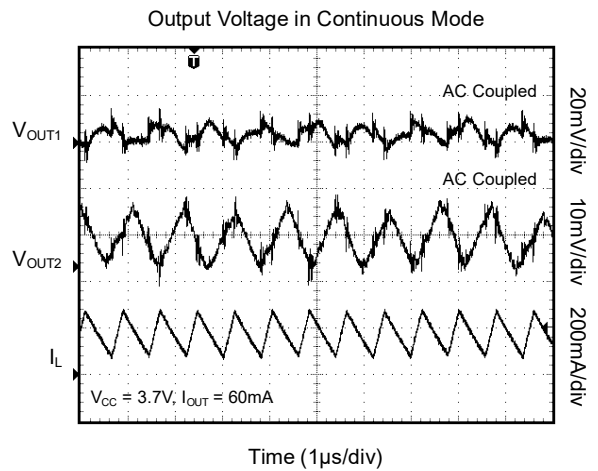
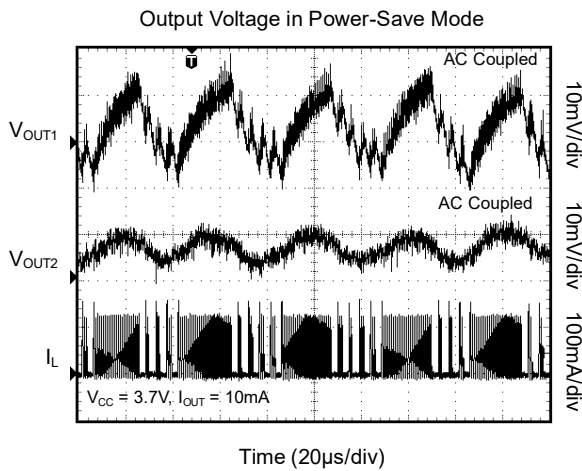
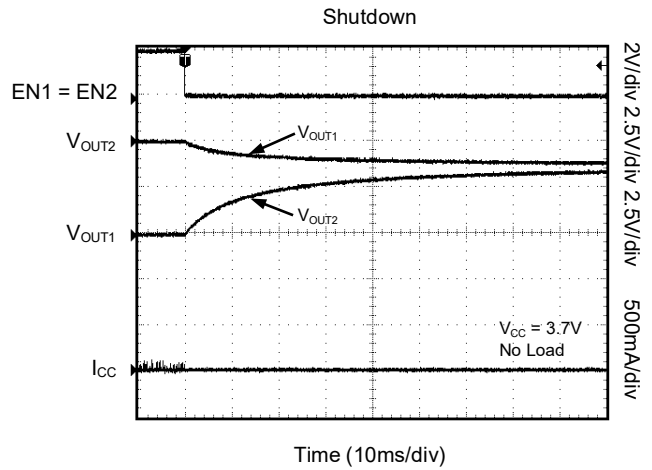
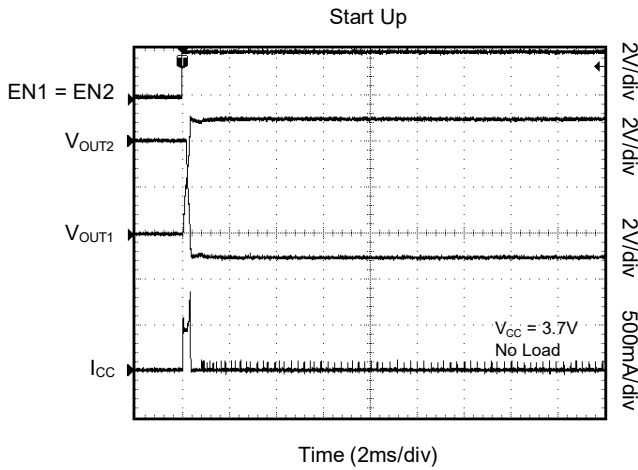
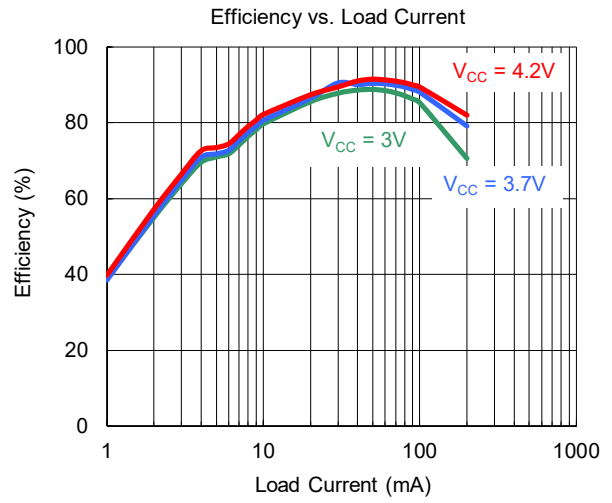
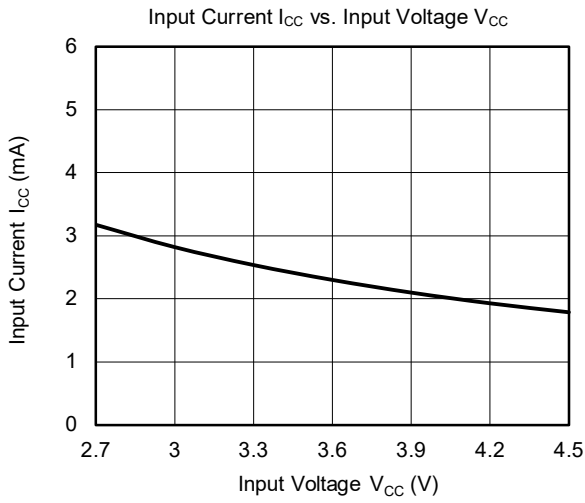

TYPICAL PERFORMANCE CHARACTERISTICS (continued)

All the curves are measured with typical application, and load current I_{OUT} is between V_{OUT1} and V_{OUT2} , unless otherwise noted.

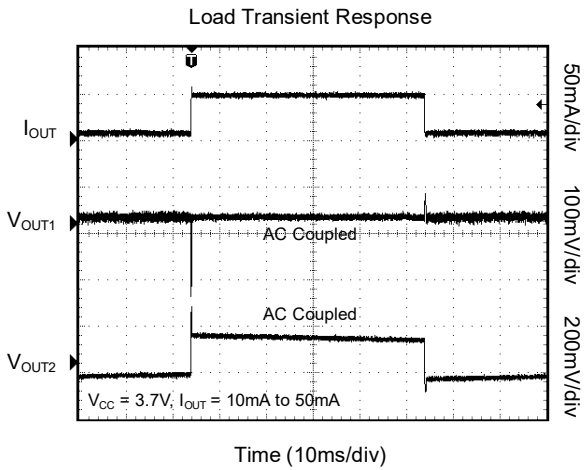
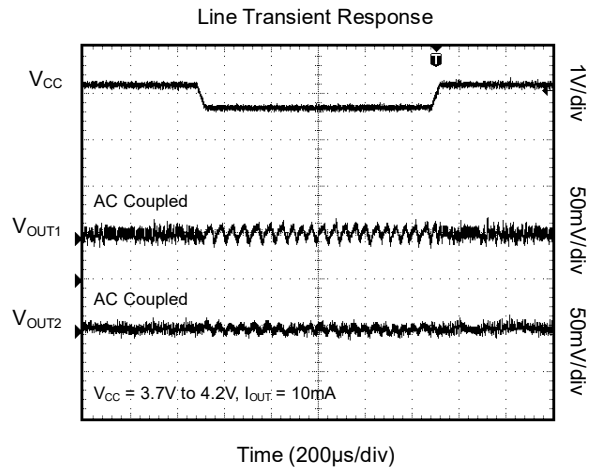
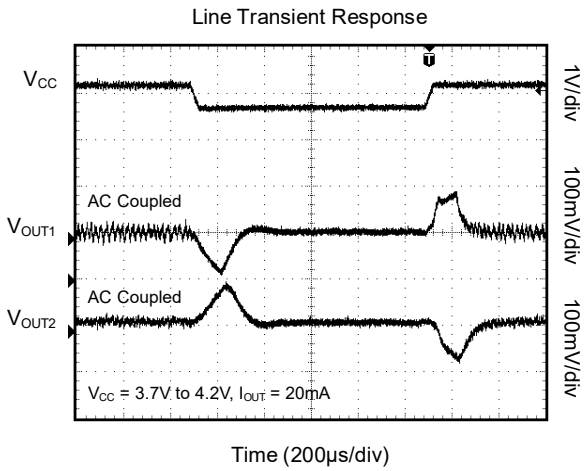

TYPICAL APPLICATION

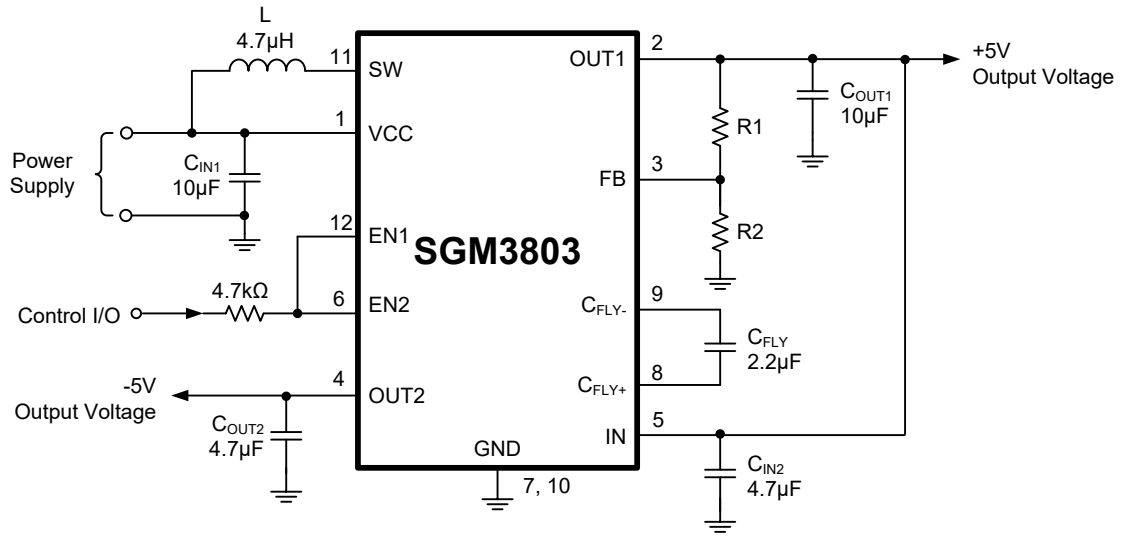

90% Efficient Synchronous Step-Up Converter with 200mA Negative Charge Pump Inverter

SGM3803

DETAILED DESCRIPTION

Charge Pump Voltage Inverter Operating Principle

The SGM3803 charge pump inverts the voltage applied to the input. For the best performance, use low equivalent series resistance (ESR) capacitors (e.g., ceramic). During the first half-cycle, switches S2 and S4 open, switches S1 and S3 close, and capacitor C_{FLY} charges to the voltage at V_{IN}. During the second half-cycle, S1 and S3 open and S2 and S4 close. This connects the positive terminal of C_{FLY} to GND and the negative to V_{OUT2}. By connecting C_{FLY} in parallel, C_{OUT2} is charged negative. The actual voltage at the output is more positive than -V_{IN}, since switches S1-S4 have resistance and the load drains charge from C_{OUT2}.

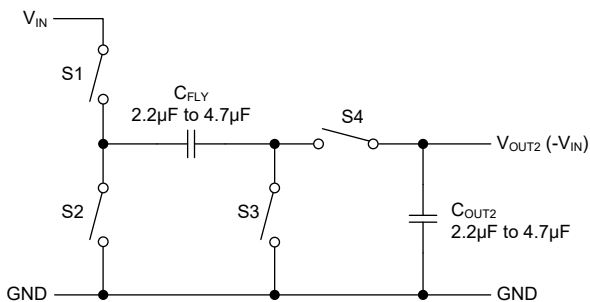

Figure 1. Operating Principle

Charge Pump Output Resistance

The charge pump output source resistance is approximately 4.2Ω at room temperature (with V_{IN} = 5V), and V_{OUT2} approaches 5V when lightly loaded. V_{OUT2} will drop toward GND as load current increases.

$$V_{OUT2} = -(V_{IN} - R_{OUT2} \times I_{OUT2})$$

$$R_{OUT2} \approx \frac{1}{f_2 \times C_{FLY}} + 4(2R_{SWITCH} + ESR_{C_{FLY}}) + ESR_{C_{OUT2}}$$

where

R_{OUT2} = output resistance of the converter.

R_{SWITCH} = resistance of a single MOSFET-switch inside the converter.

f₂ = oscillator frequency.

Efficiency Considerations of Charge Pump Inverter

The power efficiency of a switched-capacitor voltage converter is affected by three factors: the internal losses in the converter IC, the resistive losses of the capacitors, and the conversion losses during charge transfer between the capacitors. The internal losses are associated with the IC's internal functions, such as driving the switches, oscillator, etc. These losses are affected by operating conditions such as input voltage, temperature, and frequency. The next two losses are associated with the voltage converter circuit's output resistance. Switch losses occur because of the on-resistance of the MOSFET switches in the IC. Charge pump capacitor losses occur because of their ESR. The relationship between these losses and the output resistance is as follows.

$$P_{CAPACITOR\ LOSSES} + P_{CONVERSION\ LOSSES} = I_{OUT2}^2 \times R_{OUT2}$$

The first term is the effective resistance from an ideal switched-capacitor circuit. Conversion losses occur during the charge transfer between C_{FLY} and C_{OUT2} when there is a voltage difference between them. The power loss is:

$$P_{CONVERSION\ LOSS} = \left[\frac{1}{2} \times C_{FLY} (V_{IN}^2 - V_{OUT2}^2) + \frac{1}{2} C_{OUT2} (V_{OUT2RIPPLE}^2 - 2V_{OUT2} V_{OUT2RIPPLE}) \right] \times f_2$$

The efficiency of charge pump is dominated by their quiescent supply current at low output current and by their output impedance at higher current.

$$\eta \cong \frac{I_{OUT2}}{I_{OUT2} + I_Q} \left(1 - \frac{I_{OUT2} \times R_{OUT2}}{V_{IN}} \right)$$

where I_Q = quiescent current.

APPLICATION INFORMATION

Boost DC/DC Design Procedure

The SGM3803 DC/DC converter is intended for systems powered by dual to triple-cell alkaline, NiCd and NiMH battery with a typical terminal voltage between 2.7V and 5.5V. It can also be used in systems powered by one-cell Li-ion or Li-polymer with a typical voltage between 3.0V and 4.2V.

Setting Boost DC/DC Output Voltage

In "TYPICAL APPLICATION", the output voltage of the SGM3803 boost DC/DC converter can be adjusted with an external resistor divider. The typical value of the voltage at the FB pin is 500mV. The maximum recommended value for the output voltage is 5.5V. R1 and R2 are calculated as follows.

$$R1 = R2 \times \left(\frac{V_{OUT1}}{V_{FB}} - 1 \right) = R2 \times \left(\frac{V_{OUT1}}{500mV} - 1 \right)$$

R2 is recommended to be 100kΩ. For example, if an output voltage of 5.5V is needed, a 1MΩ resistor should be chosen for R1.

Boost DC/DC Inductor Selection

A boost converter normally requires two main passive components for storing energy during the conversion. A boost inductor and a storage capacitor at the output are required. To select the boost inductor, it is recommended to keep the possible peak inductor current below the current limit threshold of the power switch in the chosen configuration. The highest peak current through the inductor and the switch depends on the output load, the input (V_{CC}), and the output voltage (V_{OUT1}). Estimation of the maximum average inductor current is done using the follow.

$$I_L = I_{OUT1} \times \frac{V_{OUT1}}{V_{CC} \times 0.8}$$

For example, for an output current of 75mA at 5V, at least an average current of 170mA flows through the inductor at a minimum input voltage of 2.7V.

The second parameter for choosing the inductor is the desired current ripple in the inductor. Normally, it is advisable to work with a ripple of less than 20% of the average inductor current. A smaller ripple reduces the magnetic hysteresis losses in the inductor, as well as output voltage ripple and EMI. But in the same way, regulation time rises at load changes. In addition, a larger inductor increases the total system costs.

$$L = \frac{V_{CC} \times (V_{OUT1} - V_{CC})}{\Delta I_L \times f_1 \times V_{OUT1}}$$

Parameter f_1 is the switching frequency and ΔI_L is the ripple current in the inductor. In typical applications, a 4.7μH inductance is recommended. The device has been optimized to operate with inductance values between 2.2μH and 10μH. Nevertheless, operation with higher inductance values may be possible in some applications. Detailed stability analysis is then recommended. Care must be taken because load transients and losses in the circuit can lead to higher currents as estimated in equation. Also, the losses in the inductor which include magnetic hysteresis losses and copper losses are a major parameter for total circuit efficiency.

Input Capacitor of Boost DC/DC

At least a 10μF input capacitor is recommended to improve transient behavior of the regulator and EMI behavior of the total power supply circuit. A ceramic capacitor or a tantalum capacitor with a 100nF ceramic capacitor in parallel, placed close to the IC, is recommended.

APPLICATION INFORMATION (continued)

Output Capacitor of Boost DC/DC

The major parameter necessary to define the output capacitor is the maximum allowed output voltage ripple of the converter. This ripple is determined by two parameters of the capacitor, the capacitance and the ESR. It is possible to calculate the minimum capacitance needed for the defined ripple, supposing that the ESR is zero, by using following equation:

$$C_{\text{MIN}} = \frac{I_{\text{OUT1}} \times (V_{\text{OUT1}} - V_{\text{CC}})}{f_1 \times \Delta V \times V_{\text{OUT1}}}$$

Parameter f_1 is the switching frequency and ΔV is the maximum allowed ripple.

With a chosen ripple voltage of 10mV, a minimum capacitance of 4.5 μ F is needed. In this value range, ceramic capacitors are a good choice. The ESR and the additional ripple created are negligible.

$$\Delta V_{\text{ESR}} = I_{\text{OUT1}} \times R_{\text{ESR}}$$

The total ripple is the sum of the ripple caused by the capacitance and the ripple caused by the ESR of the capacitor. Additional ripple is caused by load transients. This means that the output capacitor has to completely supply the load during the charging phase of the inductor.

The value of the output capacitance depends on the speed of the load transients and the load current during the load change. With the calculated minimum value of 4.5 μ F and load transient considerations, the recommended output capacitance value is in the range of 4.7 μ F to 22 μ F.

Care must be taken on capacitance loss caused by derating due to the applied dc voltage and the frequency characteristic of the capacitor. For example, larger form factor capacitors (in 1206 size) have their self resonant frequencies in the same frequency range as the SGM3803 operating frequency. So the effective capacitance of the capacitors used may be significantly lower. Therefore, the recommendation is to use smaller capacitors in parallel instead of one larger capacitor.

Capacitor Selection of Charge Pump Inverter

To maintain the lowest output resistance, use capacitors with low ESR (see Table 1). The charge pump output resistance is a function of C_{FLY} 's and C_{OUT} 's ESR. Therefore, minimizing the charge-pump capacitor's ESR minimizes the total output resistance. The capacitor values are closely linked to the required output current and the output noise and ripple requirements. It is possible to only use 3.3 μ F capacitors of the same type.

Table 1. Recommended Capacitor Values

V _{IN} (V)	I _{OUT2} (mA)	C _{IN2} (μ F)	C _{FLY} (μ F)	C _{OUT2} (μ F)
1.4 to 5.5	200	2.2 ~ 4.7	2.2 ~ 4.7	2.2 ~ 4.7

Input Capacitor of Charge Pump

Bypass the incoming supply to reduce its AC impedance and the impact of the charge pump switching noise. The recommended bypassing depends on the circuit configuration and where the load is connected. When the inverter is loaded from OUT2 to GND, current from the supply switches between $2 \times I_{\text{OUT2}}$ and zero. Therefore, use a large bypass capacitor (e.g., equal to the value of C_{FLY}) if the supply has high AC impedance. When the inverter is loaded from IN to OUT2, the circuit draws $2 \times I_{\text{OUT2}}$ constantly, except for short switching spikes. A 0.1 μ F bypass capacitor is sufficient.

Flying Capacitor of Charge Pump

Increasing the flying capacitor's size reduces the output resistance. Small values increase the output resistance. Above a certain point, increasing C_{FLY} 's capacitance has a negligible effect, because the output resistance becomes dominated by the internal switch resistance and capacitor ESR.

Output Capacitor of Charge Pump

Increasing the output capacitor's size reduces the output ripple voltage. Decreasing its ESR reduces both output resistance and ripple. Smaller capacitance values can be used with light loads if higher output ripple can be tolerated. Use the following equation to calculate the peak-to-peak ripple.

$$V_{\text{OUT2RIPPLE}} = \frac{I_{\text{OUT2}}}{f_2 \times C_{\text{OUT2}}} + 2 \times I_{\text{OUT2}} \times \text{ESR}_{\text{COUT2}}$$

APPLICATION INFORMATION (continued)

Layout Considerations of Boost DC/DC

As for all switching power supplies, the layout is an important step in the design, especially at high-peak currents and high switching frequencies. If the layout is not carefully done, the regulator could show stability problems as well as EMI problems. Therefore, use wide and short traces for the main current path and for the power ground tracks. The input capacitor, output capacitor, and the inductor should be placed as close as possible to the IC. Use a common ground node for power ground and a different one for control ground to minimize the effects of ground noise. Connect these ground nodes at any place close to the ground pin of the IC.

The feedback divider should be placed as close as possible to the ground pin of the IC. To lay out the control ground, it is recommended to use short traces as well, separated from the power ground traces. This avoids ground shift problems, which can occur due to superimposition of power ground current and control ground current.

Thermal Information

Implementation of integrated circuits in low-profile and fine-pitch surface-mount packages typically requires special attention to power dissipation. Many system-dependent issues such as thermal coupling, airflow, added heat sinks and convection surfaces, and the presence of other heat-generating components affect the power-dissipation limits of a given component.

Three basic approaches for enhancing thermal performance follow.

- 1. Improving the power dissipation capability of the PCB design.
2. Improving the thermal coupling of the component to the PCB.
3. Introducing airflow in the system.

REVISION HISTORY

NOTE: Page numbers for previous revisions may differ from page numbers in the current version.

JUNE 2014 – REV.A to REV.A.1 Page
Changed 3.3µF Capacitors to 2.2µF ~ 4.7µF All

Changes from Original (APRIL 2014) to REV.A Page
Changed from product preview to production data..... All

PACKAGE OUTLINE DIMENSIONS

TDFN-3x3-12L

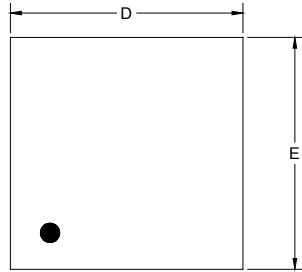

TOP VIEW

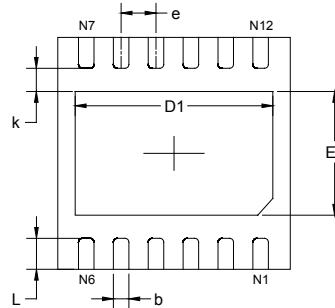

BOTTOM VIEW



SIDE VIEW

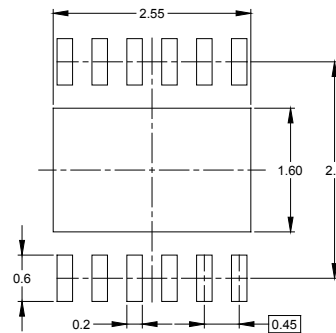

RECOMMENDED LAND PATTERN (Unit: mm)

Symbol	Dimensions In Millimeters		Dimensions In Inches	
	MIN	MAX	MIN	MAX
A	0.700	0.800	0.028	0.031
A1	0.000	0.050	0.000	0.002
A2	0.203 REF		0.008 REF	
D	2.924	3.076	0.115	0.121
D1	2.450	2.650	0.096	0.104
E	2.924	3.076	0.115	0.121
E1	1.500	1.700	0.059	0.067
k	0.200 MIN		0.008 MIN	
b	0.150	0.250	0.006	0.010
e	0.450 TYP		0.018 TYP	
L	0.324	0.476	0.013	0.019

PACKAGE INFORMATION

TAPE AND REEL INFORMATION

REEL DIMENSIONS

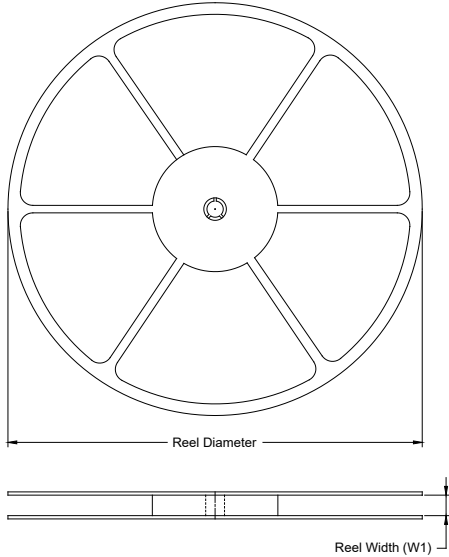

TAPE DIMENSIONS

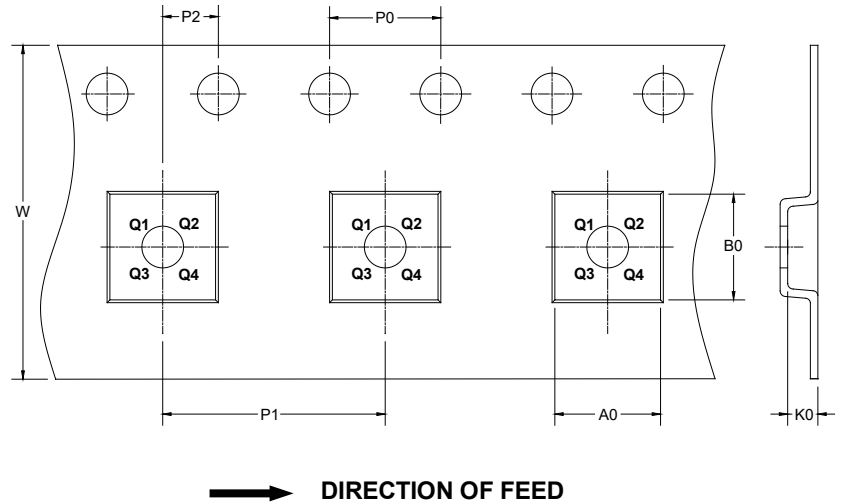

NOTE: The picture is only for reference. Please make the object as the standard.

KEY PARAMETER LIST OF TAPE AND REEL

Package Type	Reel Diameter	Reel Width W1 (mm)	A0 (mm)	B0 (mm)	K0 (mm)	P0 (mm)	P1 (mm)	P2 (mm)	W (mm)	Pin1 Quadrant
TDFN-3×3-12L	13"	12.4	3.30	3.30	1.10	4.0	8.0	2.0	12.0	Q1

DD0001

PACKAGE INFORMATION

CARTON BOX DIMENSIONS

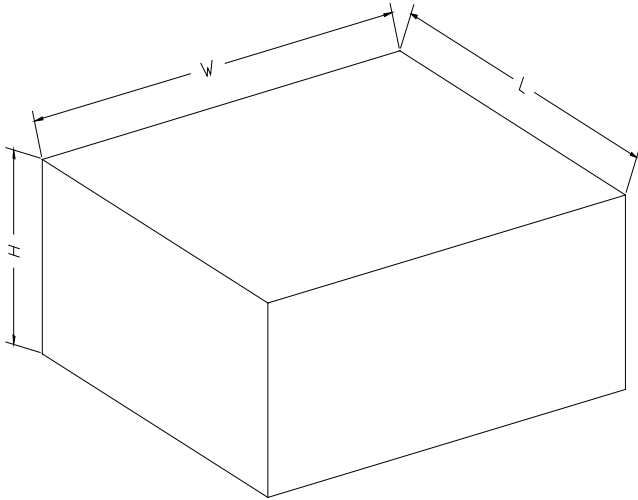

NOTE: The picture is only for reference. Please make the object as the standard.

KEY PARAMETER LIST OF CARTON BOX

Reel Type	Length (mm)	Width (mm)	Height (mm)	Pizza/Carton
13"	386	280	370	5

DD0002