



SGM4518

36V High Voltage, CMOS Analog Multiplexer

GENERAL DESCRIPTION

The SGM4518 is a high voltage, CMOS analog IC configured as an 8-channel multiplexer.

This CMOS device can operate from $\pm 3.2\text{V}$ to $\pm 18\text{V}$ dual power supplies or from $+3.2\text{V}$ to $+36\text{V}$ single supply. Each switch can handle rail-to-rail analog signals. The off leakage current is only $0.01\mu\text{A}$ (TYP).

All digital inputs have 0.8V to 2.4V logic thresholds, ensuring TTL/CMOS-logic compatibility when using a single $+5\text{V}$ supply or dual $\pm 5\text{V}$ supplies.

The SGM4518 is available in Green SOIC-16, SSOP-16, TSSOP-16 and TQFN-3 \times 3-16L packages. It operates over an operating temperature range of -40°C to $+125^\circ\text{C}$.

FEATURES

- **On-Resistance:**
 22Ω (TYP) with Single 36V Supply
- **Low Off Leakage Current: $0.01\mu\text{A}$ (TYP)**
- **Low On Leakage Current: $0.01\mu\text{A}$ (TYP)**
- **$\pm 3.2\text{V}$ to $\pm 18\text{V}$ Dual-Supply Operation or $+3.2\text{V}$ to $+36\text{V}$ Single-Supply Operation**
- **TTL/CMOS-Logic Compatible**
- **Low Distortion: 0.001% (TYP) ($R_L = 600\Omega$, $f = 1\text{kHz}$)**
- **High Off-Isolation: -85dB (TYP) ($R_L = 50\Omega$, $f = 1\text{MHz}$)**
- **-40°C to $+125^\circ\text{C}$ Operating Temperature Range**
- **Available in Green SOIC-16, SSOP-16, TSSOP-16 and TQFN-3 \times 3-16L Packages**

APPLICATIONS

Battery-Operated Equipment
Audio and Video Signal Routing
Low Voltage Data Acquisition Systems
Communications Circuits

PACKAGE/ORDERING INFORMATION

MODEL	PACKAGE DESCRIPTION	SPECIFIED TEMPERATURE RANGE	ORDERING NUMBER	PACKAGE MARKING	PACKING OPTION
SGM4518	SOIC-16	-40°C to +125°C	SGM4518XS16G/TR	SGM4518XS16 XXXXX	Tape and Reel, 2500
	SSOP-16	-40°C to +125°C	SGM4518XQS16G/TR	SGM4518 XQS16 XXXXX	Tape and Reel, 4000
	TSSOP-16	-40°C to +125°C	SGM4518XTS16G/TR	SGM4518 XTS16 XXXXX	Tape and Reel, 4000
	TQFN-3×3-16L	-40°C to +125°C	SGM4518XTQ16G/TR	4518TQ XXXXX	Tape and Reel, 4000

MARKING INFORMATION

NOTE: XXXXX = Date Code, Trace Code and Vendor Code.

XXXXX

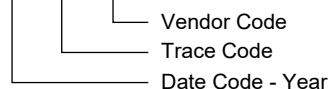

Green (RoHS & HSF): SG Micro Corp defines "Green" to mean Pb-Free (RoHS compatible) and free of halogen substances. If you have additional comments or questions, please contact your SGMICRO representative directly.

ABSOLUTE MAXIMUM RATINGS

Voltages Referenced to V_{EE}

V_{CC}	-0.3V to 40V
GND	-0.3V to 40V
Analog Switch I/O Voltage, V_{IS}	$(V_{EE} - 0.3V)$ to $(V_{CC} + 0.3V)$
Digital Control Voltage	$(GND - 0.3V)$ to $(V_{CC} + 0.3V)$
Continuous Current into Analog Switch I/O, $X_{(1)}$ or $X_{...}$	$\pm 40mA$
Junction Temperature	+150°C
Storage Temperature Range	-65°C to +150°C
Lead Temperature (Soldering, 10s)	+260°C
ESD Susceptibility	
HBM	4000V
CDM	1000V

RECOMMENDED OPERATING CONDITIONS

Operating Temperature Range	-40°C to +125°C
-----------------------------------	-----------------

NOTE:

1. $X_{...}$: Analog Switch Inputs X0-X7.

OVERSTRESS CAUTION

Stresses beyond those listed in Absolute Maximum Ratings may cause permanent damage to the device. Exposure to absolute maximum rating conditions for extended periods may affect reliability. Functional operation of the device at any conditions beyond those indicated in the Recommended Operating Conditions section is not implied.

ESD SENSITIVITY CAUTION

This integrated circuit can be damaged if ESD protections are not considered carefully. SGMICRO recommends that all integrated circuits be handled with appropriate precautions. Failure to observe proper handling and installation procedures can cause damage. ESD damage can range from subtle performance degradation to complete device failure. Precision integrated circuits may be more susceptible to damage because even small parametric changes could cause the device not to meet the published specifications.

DISCLAIMER

SG Micro Corp reserves the right to make any change in circuit design, or specifications without prior notice.

PIN CONFIGURATIONS

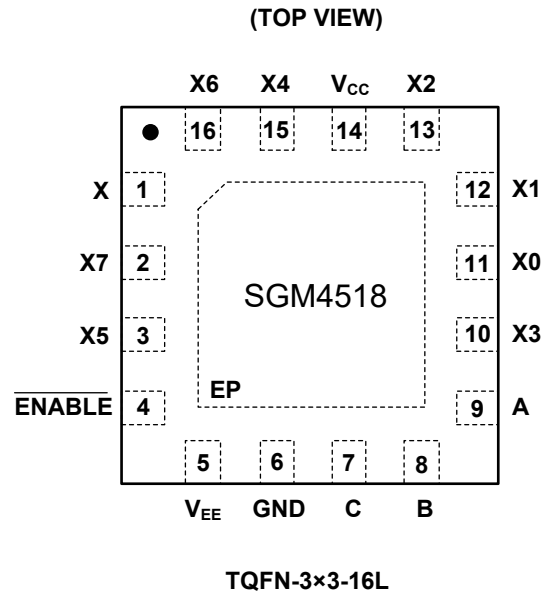
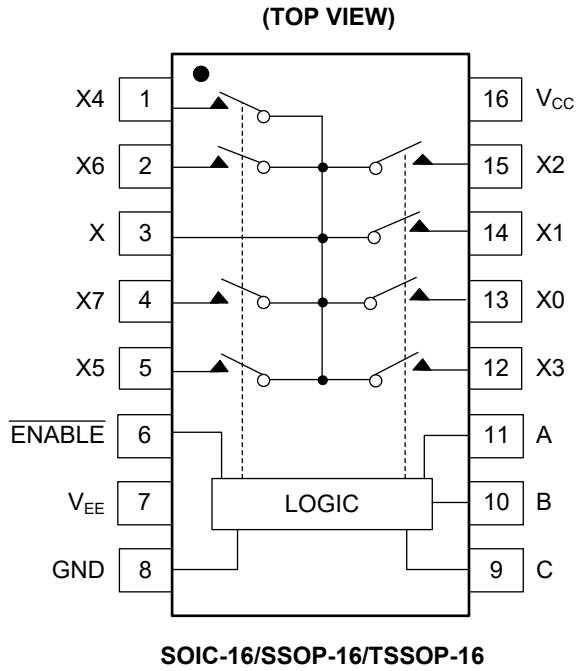

PIN DESCRIPTION

PIN		NAME	FUNCTION
SOIC-16, SSOP-16, TSSOP-16	TQFN-3x3-16L		
13, 14, 15, 12, 1, 5, 2, 4	11, 12, 13, 10, 15, 3, 16, 2	X0-X7	Analog Switch Inputs X0-X7.
3	1	X	Analog Switch "X" Output.
16	14	V _{CC}	Positive Analog and Digital Supply Voltage Input.
11	9	A	Digital Address "A" Input.
10	8	B	Digital Address "B" Input.
9	7	C	Digital Address "C" Input.
8	6	GND	Ground. Connect to digital ground. (Analog signals have no ground reference; they are limited to V _{CC} and V _{EE} .)
7	5	V _{EE}	Negative Analog Supply Voltage Input. Connect to GND for single-supply operation.
6	4	ENABLE	Digital Enable Input (Active Low).
—	Exposed Pad	EP	Exposed Pad. It can be connected to V _{EE} or be left floating.

NOTE: Input and output pins are identical and interchangeable. Either may be considered as an input or output; signals pass equally well in both directions.

FUNCTION TABLE

$\overline{\text{ENABLE}}$ Input	Select Inputs			On Switches
	C	B	A	
H	X	X	X	All Switches Open
L	L	L	L	X-X0
L	L	L	H	X-X1
L	L	H	L	X-X2
L	L	H	H	X-X3
L	H	L	L	X-X4
L	H	L	H	X-X5
L	H	H	L	X-X6
L	H	H	H	X-X7

X = Don't care.

ELECTRICAL CHARACTERISTICS

(V_{CC} = 3.2V to 36V, V_{EE} = 0V, GND = 0V, Full = -40°C to +125°C, typical values are at T_A = +25°C, unless otherwise noted.)

PARAMETER	SYMBOL	CONDITIONS	TEMP	MIN	TYP	MAX	UNITS
Analog Switch							
Analog Signal Range	V _{X-} , V _X		Full	V _{EE}		V _{CC}	V
On-Resistance	R _{ON}	V _{CC} = 3.2V, I _X = 10mA	+25°C		26	34	Ω
			Full			44	
		V _{CC} = 5V to 36V, I _X = 10mA	+25°C		22	29	
			Full			45	
On-Resistance Match Between Channels	ΔR _{ON}	V _{CC} = 3.2V, I _X = 10mA	+25°C		0.1	4	Ω
			Full			5	
		V _{CC} = 5V to 36V, I _X = 10mA	+25°C		0.2	3	
			Full			4	
On-Resistance Flatness	R _{FLAT(ON)}	V _{CC} = 3.2V, I _X = 10mA	+25°C		8	14	Ω
			Full			18	
		V _{CC} = 5V to 36V, I _X = 10mA	+25°C		11	17	
			Full			26	
X ₋ Off Leakage Current	I _{X(OFF)}	V _{CC} = 18V, V _{EE} = -18V, V _{X-} = ±18V, V _X = ∓18V	Full		0.01	2	μA
X Off Leakage Current	I _{X(OFF)}	V _{CC} = 18V, V _{EE} = -18V, V _{X-} = ±18V, V _X = ∓18V	Full		0.01	2	μA
X On Leakage Current	I _{X(ON)}	V _{CC} = 18V, V _{EE} = -18V, V _{X-} = ±18V, V _X = Floating	Full		0.01	1.5	μA
Digital I/O							
Input High Voltage	V _{AH} , V _{BH} , V _{CH} , V _{ENABLEH}		Full	2.4			V
Input Low Voltage	V _{AL} , V _{BL} , V _{CL} , V _{ENABLEL}		Full			0.8	V
High-Level Input Current	I _{AH} , I _{BH} , I _{CH} , I _{ENABLEH}	V _A , V _B , V _C , V _{ENABLE} = V _{CC}	+25°C		0.3	1	μA
			Full			1.5	
Low-Level Input Current	I _{AL} , I _{BL} , I _{CL} , I _{ENABLEL}	V _A , V _B , V _C , V _{ENABLE} = 0V	+25°C		0.01	1	μA
			Full			1.5	
Dynamic Characteristics							
Address Transition Time	t _{TRANS}	V _{CC} = 5V, V _{EE} = 0V, V _{X-} = 3V, 0V, C _L = 35pF, R _L = 300Ω, Test Circuit 1	+25°C		150		ns
		V _{CC} = 18V, V _{EE} = -18V, V _{X-} = 3V, -3V, C _L = 35pF, R _L = 300Ω, Test Circuit 1	+25°C		130		
ENABLE Turn-On Time	t _{ON}	V _{CC} = 5V, V _{EE} = 0V, V _{X-} = 3V, C _L = 35pF, R _L = 300Ω, Test Circuit 2	+25°C		80		ns
		V _{CC} = 18V, V _{EE} = -18V, V _{X-} = 3V, C _L = 35pF, R _L = 300Ω, Test Circuit 2	+25°C		70		
ENABLE Turn-Off Time	t _{OFF}	V _{CC} = 5V, V _{EE} = 0V, V _{X-} = 3V, C _L = 35pF, R _L = 300Ω, Test Circuit 2	+25°C		160		ns
		V _{CC} = 18V, V _{EE} = -18V, V _{X-} = 3V, C _L = 35pF, R _L = 300Ω, Test Circuit 2	+25°C		120		
Break-Before-Make Time	t _D	V _{CC} = 5V to 36V, V _{X-} = 3V, C _L = 35pF, R _L = 300Ω, Test Circuit 3	+25°C		70		ns
Charge Injection	Q	V _{CC} = 5V, V _{EE} = 0V, R _S = 0Ω, C _L = 1nF, V _S = 0V, Test Circuit 4	+25°C		90		pC
		V _{CC} = 18V, V _{EE} = -18V, R _S = 0Ω, C _L = 1nF, V _S = 0V, Test Circuit 4	+25°C		160		
Off Isolation	O _{ISO}	V _{CC} = 5V to 36V, R _L = 50Ω, f = 1MHz, Test Circuit 5	+25°C		-85		dB

ELECTRICAL CHARACTERISTICS (continued)(V_{CC} = 3.2V to 36V, V_{EE} = 0V, GND = 0V, Full = -40°C to +125°C, typical values are at T_A = +25°C, unless otherwise noted.)

PARAMETER	SYMBOL	CONDITIONS	TEMP	MIN	TYP	MAX	UNITS
Dynamic Characteristics (continued)							
Input Off-Capacitance	C _{X(OFF)}	V _{CC} = 5V, V _{EE} = 0V, V _X = 0V, f = 1MHz, Test Circuit 6	+25°C		20		pF
		V _{CC} = 18V, V _{EE} = -18V, V _X = 0V, f = 1MHz, Test Circuit 6	+25°C		10		
Output Off-Capacitance	C _{X(OFF)}	V _{CC} = 5V, V _{EE} = 0V, V _X = 0V, f = 1MHz, Test Circuit 6	+25°C		70		pF
		V _{CC} = 18V, V _{EE} = -18V, V _X = 0V, f = 1MHz, Test Circuit 6	+25°C		25		
Output On-Capacitance	C _{X(ON)}	V _{CC} = 5V, V _{EE} = 0V, V _X = 0V, f = 1MHz, Test Circuit 6	+25°C		70		pF
		V _{CC} = 18V, V _{EE} = -18V, V _X = 0V, f = 1MHz, Test Circuit 6	+25°C		25		
-3dB Bandwidth	BW	V _{CC} = 5V, V _{EE} = 0V, R _L = 50Ω	+25°C		25		MHz
		V _{CC} = 18V, V _{EE} = -18V, R _L = 50Ω	+25°C		160		
Total Harmonic Distortion	THD	V _{CC} = 18V, V _{EE} = -18V, R _L = 600Ω, V _{OUT} = 5V _{P-P} , f = 1kHz	+25°C		0.001		%
Power Supply							
Power Supply Range (Single Supply)	V _{CC}	V _{EE} = 0V	+25°C	+3.2		+36	V
Power Supply Range (Dual Supplies)	V _{CC} , V _{EE}		+25°C	±3.2		±18	
Power Supply Current	I _{CC} , I _{EE}	V _A , V _B , V _C , V _{ENABLE} = V _{CC} or 0V	+25°C		15	24	μA
			Full			26	

TYPICAL PERFORMANCE CHARACTERISTICS

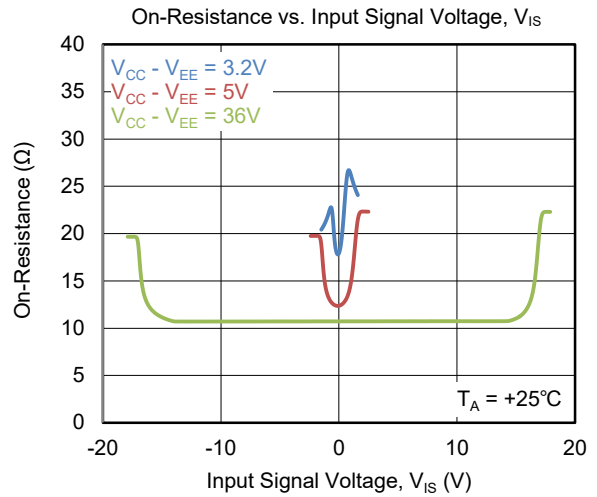
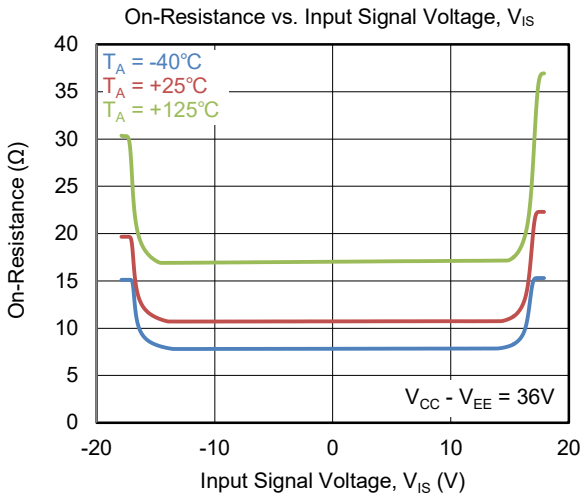
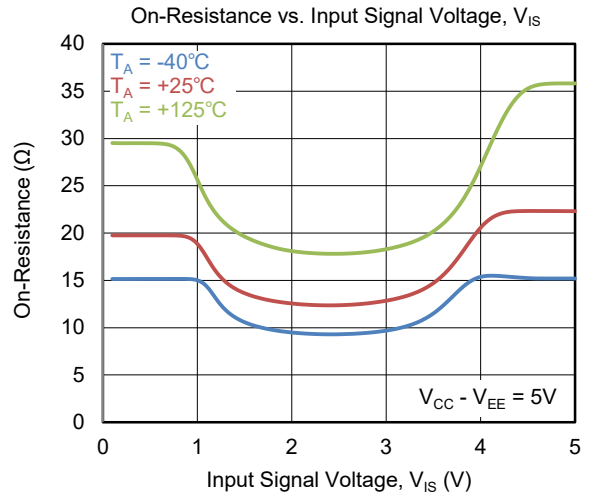
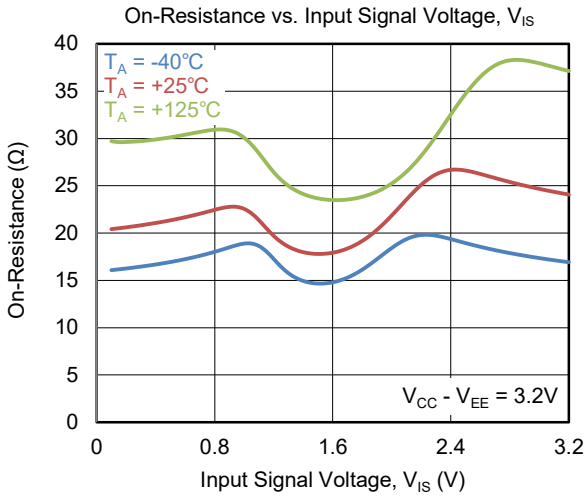

TEST CIRCUITS

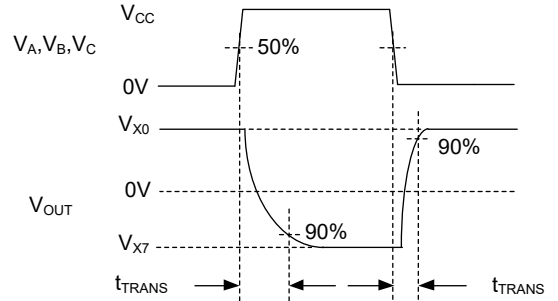
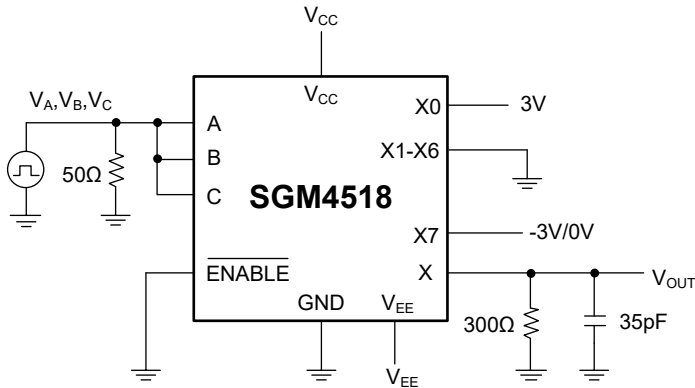

$V_{EE} = 0V$ for Single-Supply Operation.
Test Each Section Individually.

Test Circuit 1. Address Transition Times (t_{TRANS})

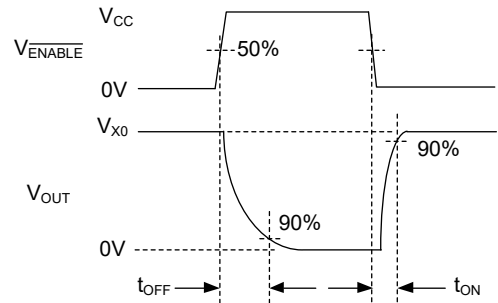
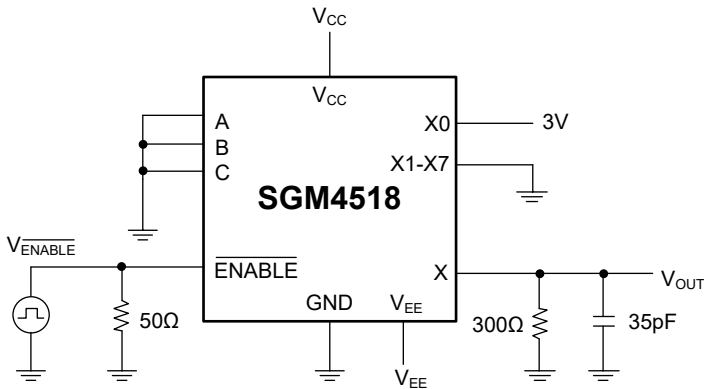

$V_{EE} = 0V$ for Single-Supply Operation.
Test Each Section Individually.

Test Circuit 2. Switching Times (t_{ON} , t_{OFF})

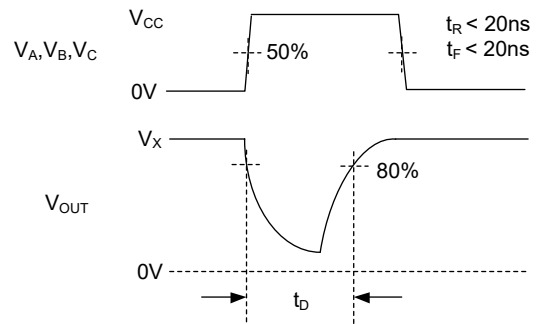
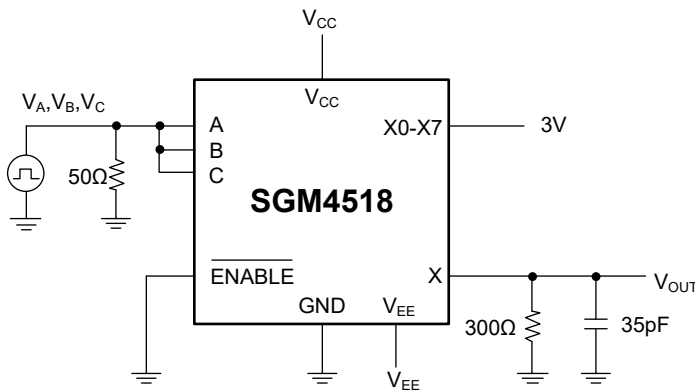

$V_{EE} = 0V$ for Single-Supply Operation.
Test Each Section Individually.

Test Circuit 3. Break-Before-Make Time (t_D)

TEST CIRCUITS (continued)

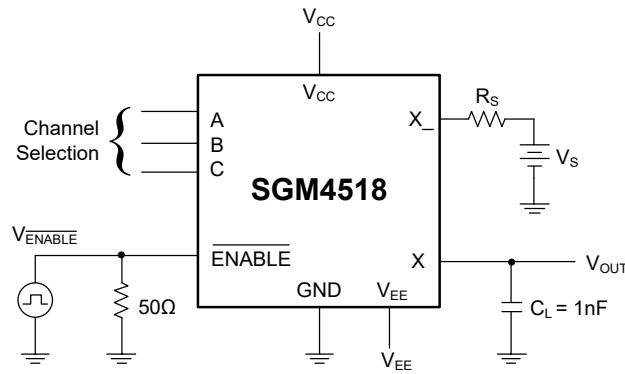

V_{EE} = 0V for Single-Supply Operation.
Test Each Section Individually.

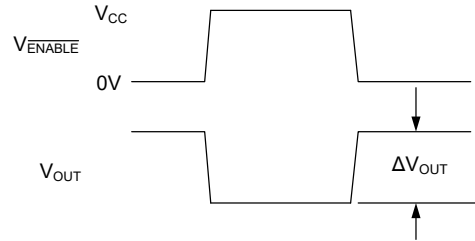

ΔV_{OUT} is the Measured Voltage due to Charge Transfer Error Q when the Channel Turns Off.
 $Q = \Delta V_{OUT} \times C_L$

Test Circuit 4. Charge Injection (Q)

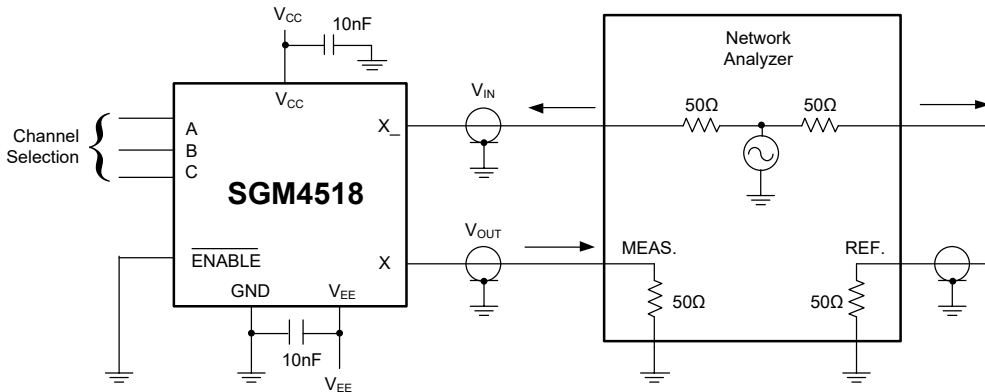

Off Isolation = $20 \log (V_{OUT}/V_{IN})$
On Loss = $20 \log (V_{OUT}/V_{IN})$

Measurements are Standardized against Short at Socket Terminals.
Off Isolation is Measured between X and "OFF" X₋ Terminal on Each Switch.
On Loss is Measured between X and "ON" X₋ Terminal on Each Switch.
Signal Direction through Switch is Reversed; Worst Values are Recorded.

Test Circuit 5. Off Isolation, On Loss

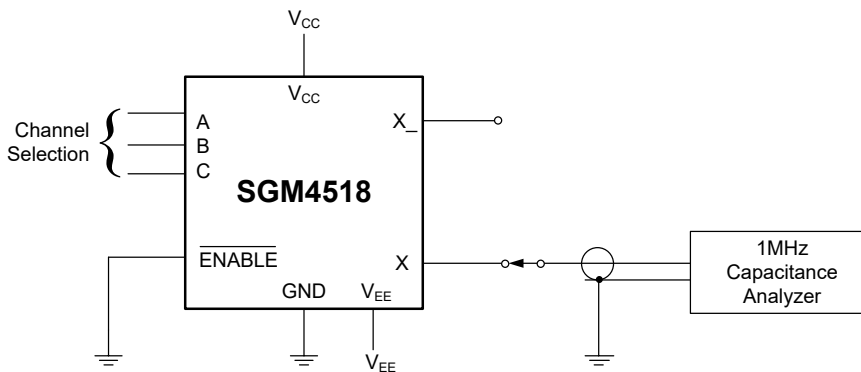

V_{EE} = 0V for Single-Supply Operation.
Test Each Section Individually.

Test Circuit 6. Capacitance

REVISION HISTORY

NOTE: Page numbers for previous revisions may differ from page numbers in the current version.

Changes from Original (DECEMBER 2020) to REV.A	Page
Changed from product preview to production data.....	All

PACKAGE OUTLINE DIMENSIONS

SOIC-16

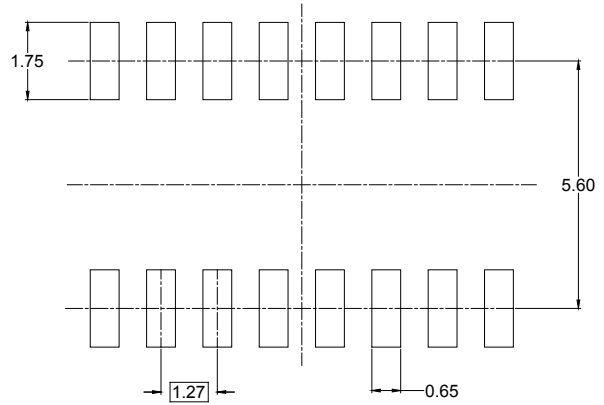
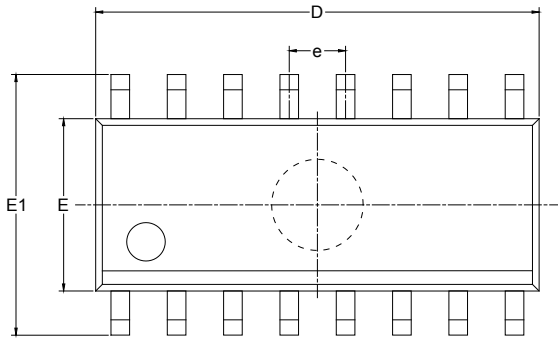

RECOMMENDED LAND PATTERN (Unit: mm)

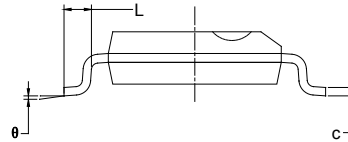
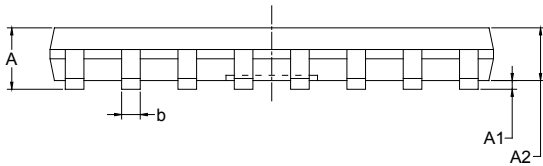

Symbol	Dimensions In Millimeters		Dimensions In Inches	
	MIN	MAX	MIN	MAX
A	1.350	1.750	0.053	0.069
A1	0.100	0.250	0.004	0.010
A2	1.350	1.550	0.053	0.061
b	0.330	0.510	0.013	0.020
c	0.170	0.250	0.006	0.010
D	9.800	10.200	0.386	0.402
E	3.800	4.000	0.150	0.157
E1	5.800	6.200	0.228	0.244
e	1.27 BSC		0.050 BSC	
L	0.400	1.270	0.016	0.050
θ	0°	8°	0°	8°

PACKAGE OUTLINE DIMENSIONS

SSOP-16

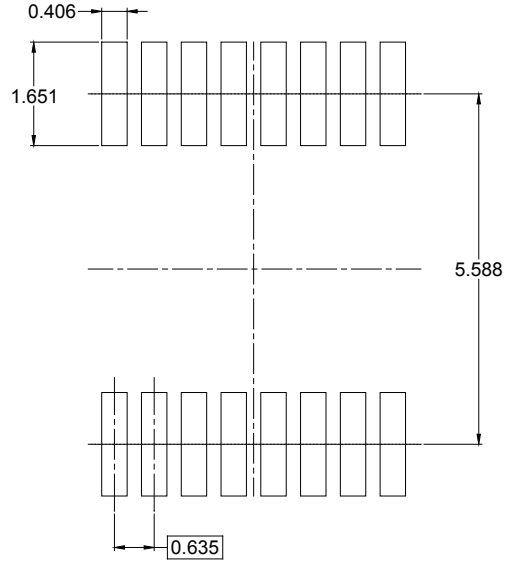
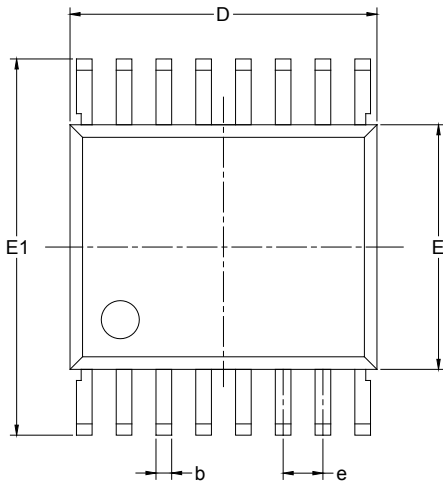

RECOMMENDED LAND PATTERN (Unit: mm)

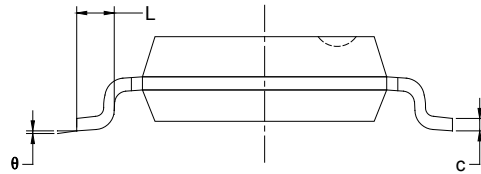
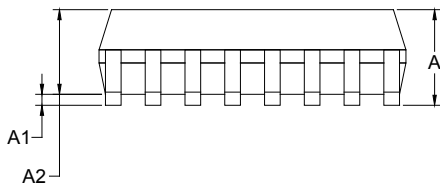

Symbol	Dimensions In Millimeters		Dimensions In Inches	
	MIN	MAX	MIN	MAX
A	1.350	1.750	0.053	0.069
A1	0.100	0.250	0.004	0.010
A2	1.350	1.550	0.053	0.061
b	0.200	0.300	0.008	0.012
c	0.170	0.250	0.007	0.010
D	4.700	5.100	0.185	0.200
E	3.800	4.000	0.150	0.157
E1	5.800	6.200	0.228	0.244
e	0.635 BSC		0.025 BSC	
L	0.400	1.270	0.016	0.050
θ	0°	8°	0°	8°

PACKAGE OUTLINE DIMENSIONS

TSSOP-16

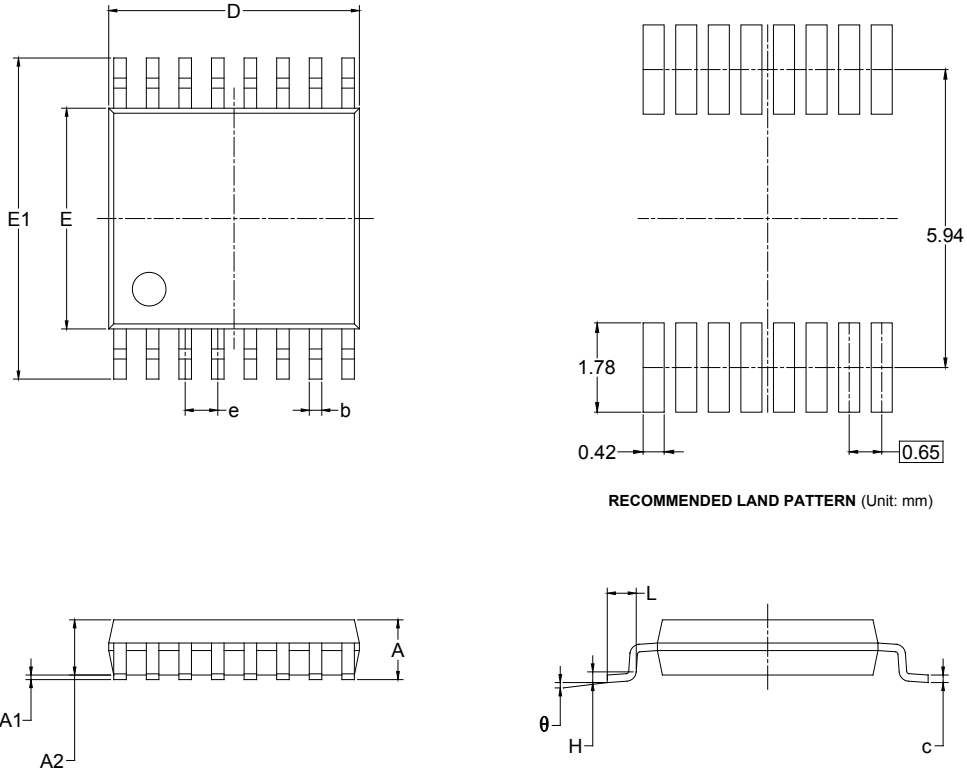

RECOMMENDED LAND PATTERN (Unit: mm)

Symbol	Dimensions In Millimeters		Dimensions In Inches	
	MIN	MAX	MIN	MAX
A		1.200		0.047
A1	0.050	0.150	0.002	0.006
A2	0.800	1.050	0.031	0.041
b	0.190	0.300	0.007	0.012
c	0.090	0.200	0.004	0.008
D	4.860	5.100	0.191	0.201
E	4.300	4.500	0.169	0.177
E1	6.200	6.600	0.244	0.260
e	0.650 BSC		0.026 BSC	
L	0.500	0.700	0.02	0.028
H	0.25 TYP		0.01 TYP	
θ	1°	7°	1°	7°

PACKAGE INFORMATION

PACKAGE OUTLINE DIMENSIONS

TQFN-3×3-16L

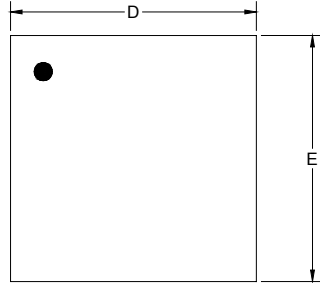

TOP VIEW

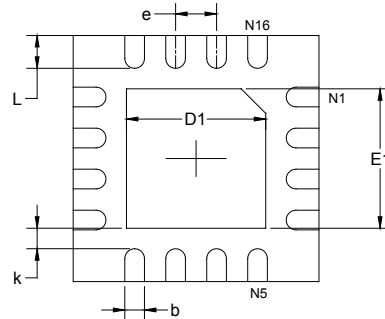

BOTTOM VIEW

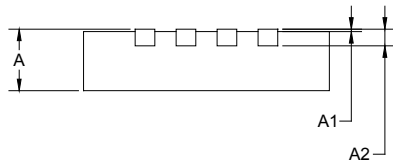

SIDE VIEW

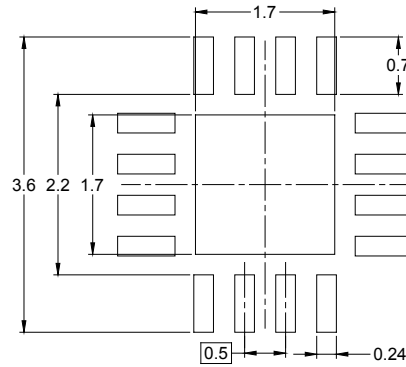

RECOMMENDED LAND PATTERN (Unit: mm)

Symbol	Dimensions In Millimeters		Dimensions In Inches	
	MIN	MAX	MIN	MAX
A	0.700	0.800	0.028	0.031
A1	0.000	0.050	0.000	0.002
A2	0.203 REF		0.008 REF	
D	2.900	3.100	0.114	0.122
D1	1.600	1.800	0.063	0.071
E	2.900	3.100	0.114	0.122
E1	1.600	1.800	0.063	0.071
k	0.200 MIN		0.008 MIN	
b	0.180	0.300	0.007	0.012
e	0.500 TYP		0.020 TYP	
L	0.300	0.500	0.012	0.020

PACKAGE INFORMATION

TAPE AND REEL INFORMATION

REEL DIMENSIONS



TAPE DIMENSIONS



NOTE: The picture is only for reference. Please make the object as the standard.

KEY PARAMETER LIST OF TAPE AND REEL

Package Type	Reel Diameter	Reel Width W1 (mm)	A0 (mm)	B0 (mm)	K0 (mm)	P0 (mm)	P1 (mm)	P2 (mm)	W (mm)	Pin1 Quadrant
SOIC-16	13"	16.4	6.50	10.30	2.10	4.0	8.0	2.0	16.0	Q1
SSOP-16	13"	12.4	6.40	5.40	2.10	4.0	8.0	2.0	12.0	Q1
TSSOP-16	13"	12.4	6.90	5.60	1.20	4.0	8.0	2.0	12.0	Q1
TQFN-3×3-16L	13"	12.4	3.35	3.35	1.13	4.0	8.0	2.0	12.0	Q2

D00001

PACKAGE INFORMATION

CARTON BOX DIMENSIONS



NOTE: The picture is only for reference. Please make the object as the standard.

KEY PARAMETER LIST OF CARTON BOX

Reel Type	Length (mm)	Width (mm)	Height (mm)	Pizza/Carton
13"	386	280	370	5

DD0002