

GENERAL DESCRIPTION

The SGM6607A is a high voltage switching regulator. It integrates a 40V low-side MOSFET to offer an output voltage up to 38V. It also accepts a wide input voltage range of 3V to 20V from multi-cell batteries or regulated 5V/12V power rails. A 1.1MHz switching frequency makes the use of low-profile inductors and low-value ceramic input and output capacitors available.

The device supports Boost, SEPIC and some other standard switching-regulator topologies. The device regulates the output with PWM (pulse width modulation) control. This device also includes the built-in functions of over-current limit, soft-start and thermal shutdown.

The SGM6607A is available in Green TDFN-2x2-6AL and TSOT-23-6 packages and is rated over the -40°C to +85°C temperature range.

FEATURES

- **Input Voltage Range: 3V to 20V**
- **Up to 38V High Output Voltage**
- **1.2A Integrated Switch**
- **1.1MHz Fixed Switching Frequency**
- **At 5V Input (TYP):**
 - 12V at 300mA**
 - 24V at 150mA**
- **Up to 93% Efficiency**
- **Skip-Switching for Light Load**
- **500kΩ Pull-Down Resistor on EN Pin**
- **Soft-Start and Thermal Shutdown Built-in Functions**
- **-40°C to +85°C Operating Temperature Range**
- **Available in Green TDFN-2x2-6AL and TSOT-23-6 Packages**

APPLICATIONS

Mobile Phones
 Portable Equipment

TYPICAL APPLICATION

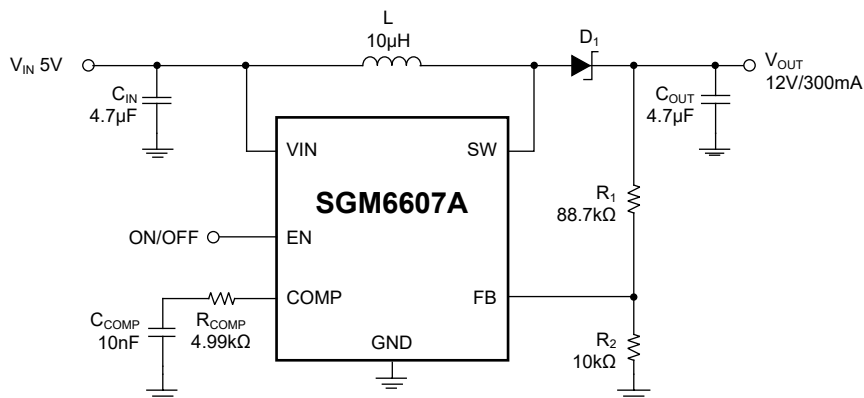

Figure 1. Typical Application Circuit

PACKAGE/ORDERING INFORMATION

MODEL	PACKAGE DESCRIPTION	SPECIFIED TEMPERATURE RANGE	ORDERING NUMBER	PACKAGE MARKING	PACKING OPTION
SGM6607A	TDFN-2×2-6AL	-40°C to +85°C	SGM6607AYTDI6G/TR	R17 XXXX	Tape and Reel, 3000
	TSOT-23-6	-40°C to +85°C	SGM6607AYTN6G/TR	RA9XX	Tape and Reel, 3000

MARKING INFORMATION

NOTE: XX = Date Code, XXXX = Date Code and Trace Code.

TSOT-23-6

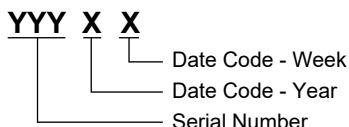

TDFN-2×2-6AL

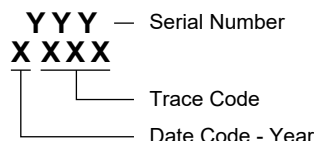

Green (RoHS & HSF): SG Micro Corp defines "Green" to mean Pb-Free (RoHS compatible) and free of halogen substances. If you have additional comments or questions, please contact your SGMICRO representative directly.

ABSOLUTE MAXIMUM RATINGS

- Supply Voltage on VIN..... -0.3V to 22V
- Voltage on EN..... -0.3V to 6V
- Voltages on FB and COMP..... -0.3V to 3V
- Voltage on SW
 - DC..... -0.3V to 40V
 - Pulse, less than 10ns..... -2.5V to 40V
 - Pulse, less than 80ns -1.0V to 40V
- Package Thermal Resistance
 - TDFN-2×2-6AL, θ_{JA} 78°C/W
 - TSOT-23-6, θ_{JA} 190°C/W
- Junction Temperature.....+150°C
- Storage Temperature Range..... -65°C to +150°C
- Lead Temperature (Soldering, 10s).....+260°C
- ESD Susceptibility
 - HBM.....4000V
 - CDM 1000V

RECOMMENDED OPERATING CONDITIONS

- Input Voltage Range.....3V to 20V
- Output Voltage Range 1.1 × V_{IN} to 38V
- Operating Ambient Temperature Range..... -40°C to +85°C
- Operating Junction Temperature Range..... -40°C to +125°C

OVERSTRESS CAUTION

Stresses beyond those listed in Absolute Maximum Ratings may cause permanent damage to the device. Exposure to absolute maximum rating conditions for extended periods may affect reliability. Functional operation of the device at any conditions beyond those indicated in the Recommended Operating Conditions section is not implied.

ESD SENSITIVITY CAUTION

This integrated circuit can be damaged if ESD protections are not considered carefully. SGMICRO recommends that all integrated circuits be handled with appropriate precautions. Failure to observe proper handling and installation procedures can cause damage. ESD damage can range from subtle performance degradation to complete device failure. Precision integrated circuits may be more susceptible to damage because even small parametric changes could cause the device not to meet the published specifications.

DISCLAIMER

SG Micro Corp reserves the right to make any change in circuit design, or specifications without prior notice.

PIN CONFIGURATIONS

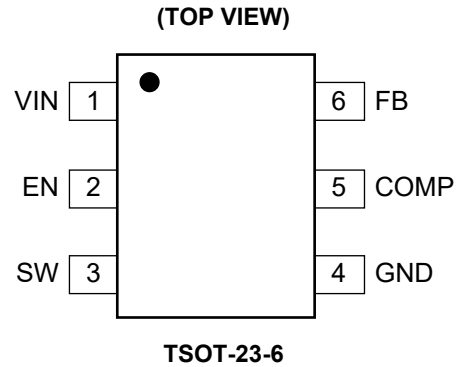
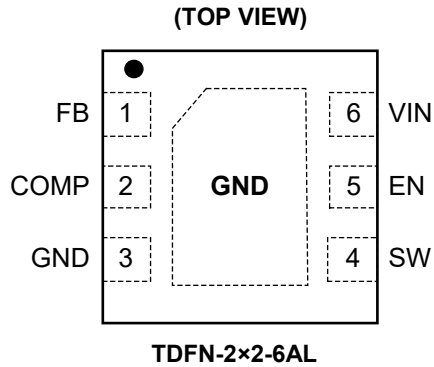

PIN DESCRIPTION

PIN		NAME	I/O	FUNCTION
TDFN-2x2-6AL	TSOT-23-6			
1	6	FB	I	Feedback Pin to Program the Output Voltage.
2	5	COMP	O	Control Loop Compensation Pin.
3	4	GND	O	Ground Pin of the IC.
4	3	SW	I	Switch Node. Drain connection of low-side power MOSFET.
5	2	EN	I	Device Enable Node. Pulling this pin logic high enables the device and pulling it logic low disables the device.
6	1	VIN	I	Power Supply Input.
Exposed Pad	—	GND	—	The exposed pad should be soldered to the GND plane. Install thermal via to connect to internal ground plane for better thermal dissipation.

ELECTRICAL CHARACTERISTICS(V_{IN} = 3.6V, V_{EN} = V_{IN}, T_J = -40°C to +85°C, typical values are at T_J = +25°C, unless otherwise noted.)

PARAMETER	SYMBOL	CONDITIONS	MIN	TYP	MAX	UNITS
Input Supply						
Input Voltage Range	V _{IN}		3		20	V
Operating Quiescent Current into VIN	I _Q	V _{EN} = V _{IN} = 3.6V, no load, device not switching		400	600	μA
Shutdown Current	I _{SHDN}	T _J = +25°C, V _{EN} = GND, V _{IN} = 4.2V			1	μA
Under-Voltage Lockout Threshold	UVLO	V _{IN} falling		2.2	2.5	V
Under-Voltage Lockout Hysteresis	V _{HYS}			70		mV
Enable and Reference Control						
EN Logic High Voltage	V _{IH}	V _{IN} = 3V to 20V	1.6			V
EN Logic Low Voltage	V _{IL}	V _{IN} = 3V to 20V			0.4	V
EN Pull-Down Resistor	R _{EN}	T _J = +25°C	300	500	700	kΩ
Voltage and Current Control						
Voltage Feedback Regulation Voltage	V _{REF}		1.203	1.229	1.255	V
Voltage Feedback Input Bias Current	I _{FB}	V _{FB} = 1.3V			300	nA
Oscillator Frequency	f _s		0.86	1.1	1.38	MHz
Maximum Duty Cycle	D	V _{FB} = 1.1V	90	95		%
Minimum ON Pulse Width	t _{MIN_ON}			80		ns
COMP Pin Sink Current	I _{SINK}			55		μA
COMP Pin Source Current	I _{SOURCE}			55		μA
Error Amplifier Transconductance	G _{EA}		200	300	440	μs
Power Switch						
N-Channel MOSFET On-Resistance	R _{DS(ON)}	T _J = +25°C, V _{IN} = 3.6V		0.36	0.55	Ω
		T _J = +25°C, V _{IN} = 3.0V			0.6	
N-Channel Leakage Current	I _{LN_NFET}	T _J = +25°C, V _{SW} = 35V, V _{EN} = 0V			1	μA
Over-Current and Soft-Start						
N-Channel MOSFET Current Limit	I _{LIM}	T _J = +25°C	0.9	1.2	1.56	A
V _{REF} Ramp Up Time	t _r			2		ms
Thermal Shutdown						
Thermal Shutdown Threshold	T _{SHDN}			150		°C
Thermal Shutdown Threshold Hysteresis	T _{HYS}			15		°C

TYPICAL PERFORMANCE CHARACTERISTICS

$T_J = +25^\circ\text{C}$, $L = 10\mu\text{H}$ and $D_1 = \text{ONsemi MBR0540T1}$, unless otherwise noted.

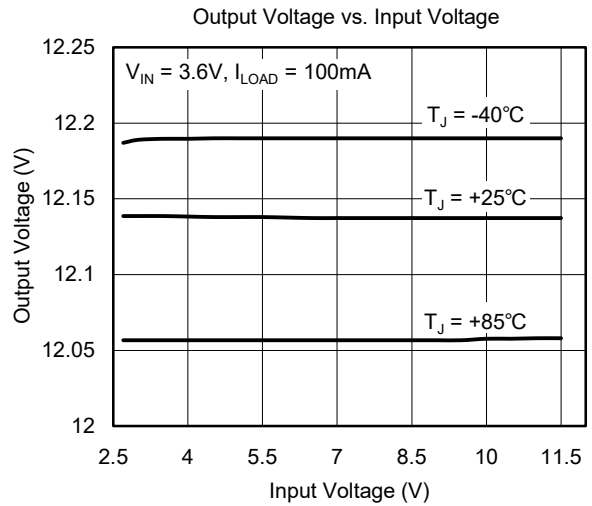
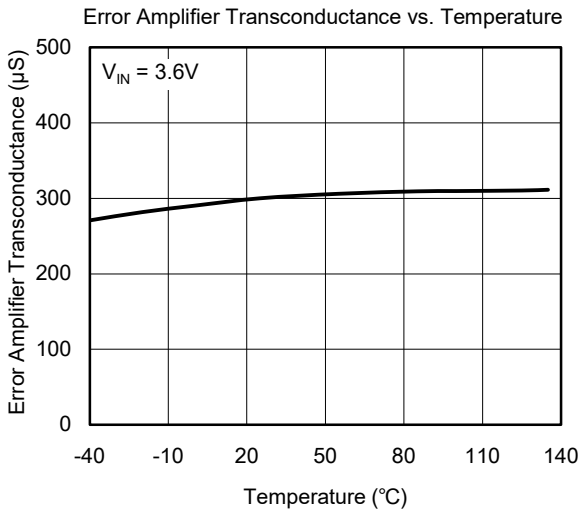
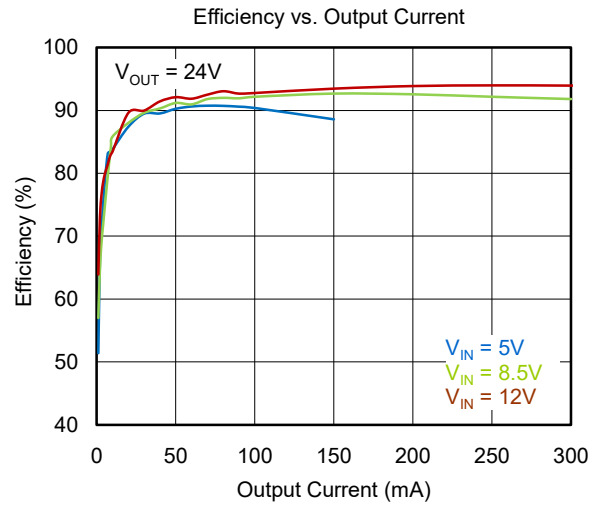
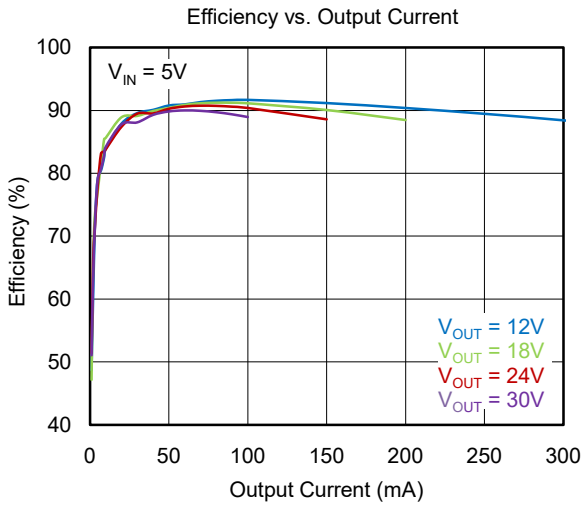

TYPICAL PERFORMANCE CHARACTERISTICS (continued)

$T_J = +25^\circ\text{C}$, $L = 10\mu\text{H}$ and $D_1 = \text{ONsemi MBR0540T1}$, unless otherwise noted.

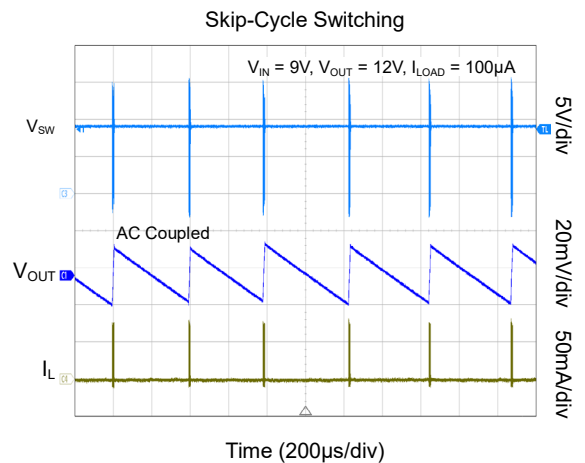
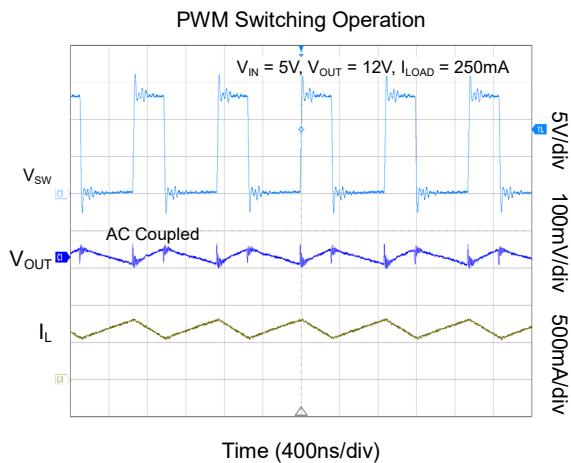
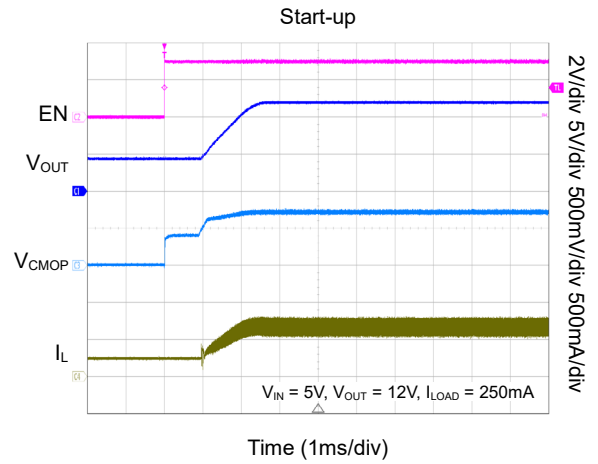
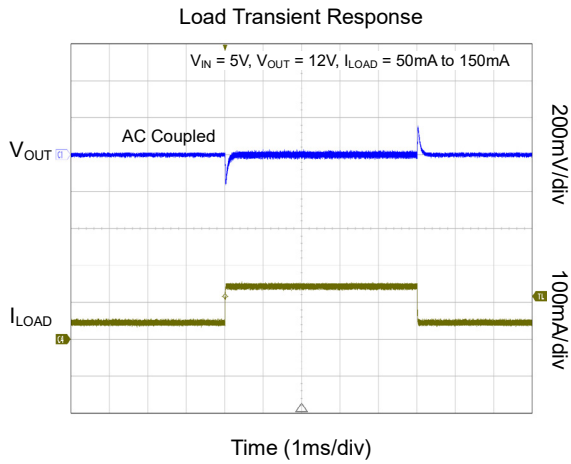

TYPICAL APPLICATION CIRCUITS

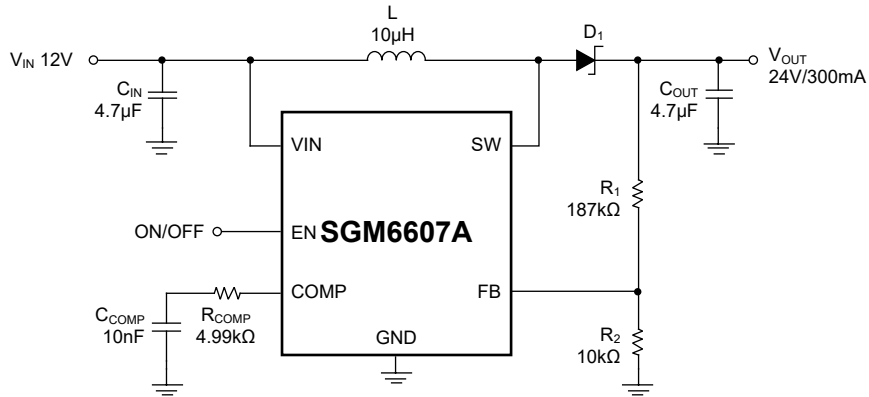

Figure 2. 12V to 24V DC/DC Power Conversion

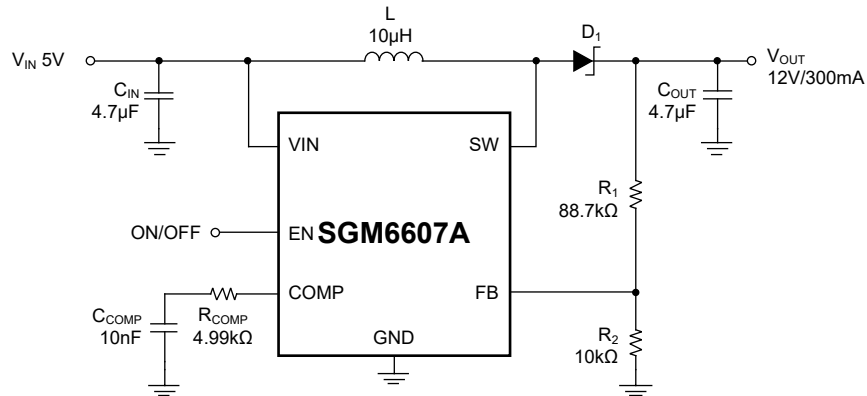

Figure 3. 5V to 12V DC/DC Power Conversion

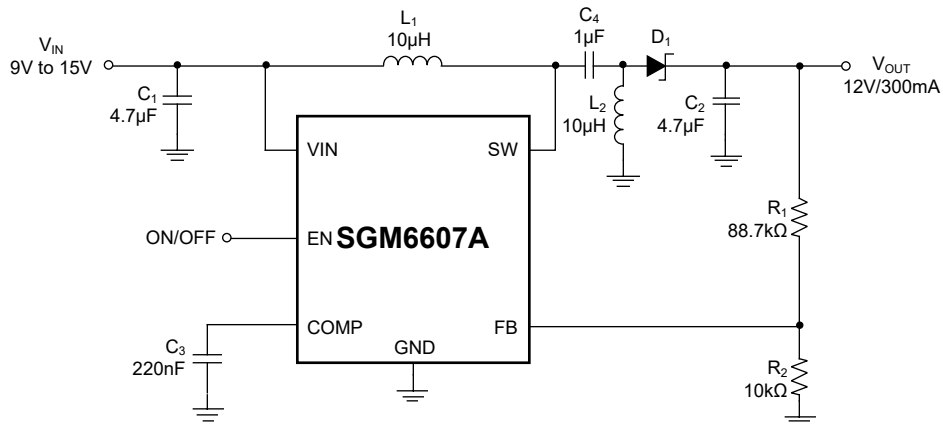

Figure 4. 12V SEPIC (Buck-Boost) Converter

FUNCTIONAL BLOCK DIAGRAM

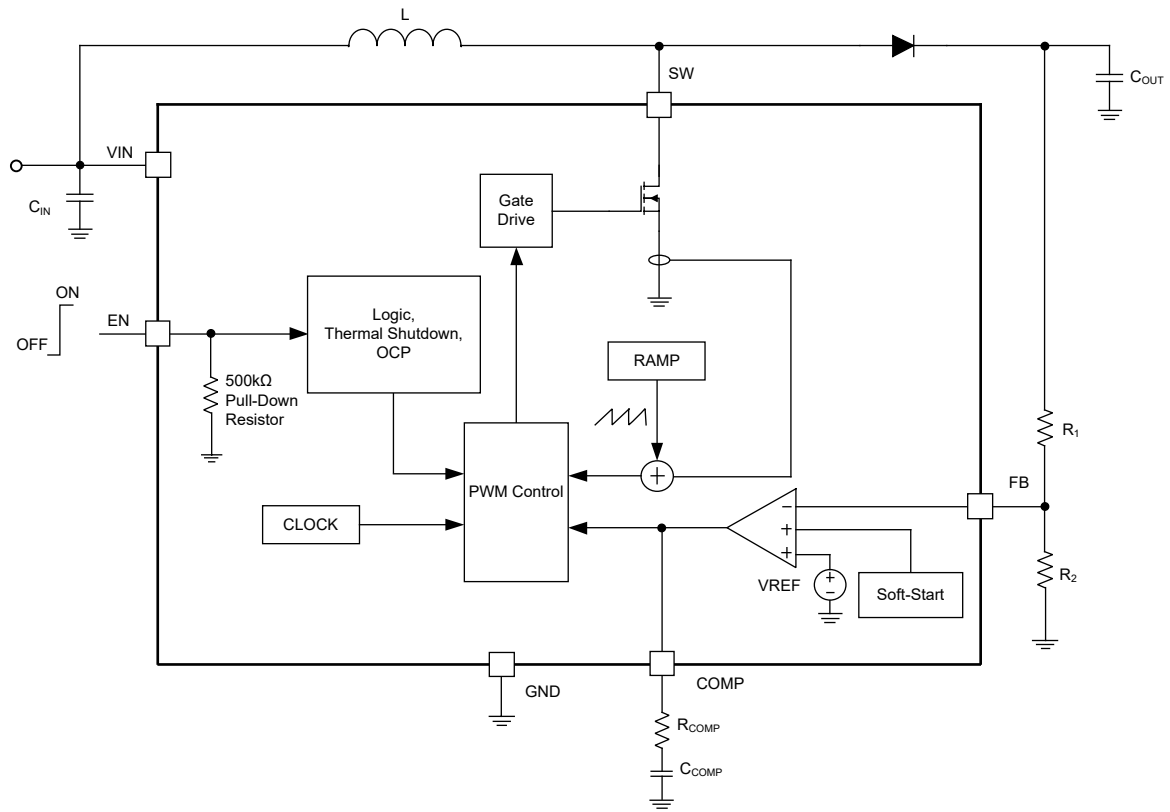

Figure 5. Functional Block Diagram

DETAILED DESCRIPTION**Operation**

The SGM6607A is a non-synchronous Boost converter with integrated low-side power FET, capable of delivering up to 38V DC output. The SGM6607A adopts the peak current mode control architecture with fixed 1.1MHz switching frequency. A slope ramp is added to the sensed peak current ramp to avoid sub-harmonic oscillation at operation duty cycle higher than 40%. The error amplifier compares the FB pin voltage with an internal reference signal to provide an error signal for the PWM comparator to adjust the duty cycle, which ultimately regulates the output voltage to the desired voltage. At the beginning of each clock cycle, the PWM comparator turns on the low-side (LS) FET to ramp up the inductor current. As the inductor current reaches the level set by the error amplifier's output, the LS FET turns off, which causes the external Schottky diode to be forward biased to ramp down the inductor current which delivers the energy to the load as well as replenishes the output capacitor.

Soft-Start

The SGM6607A implements the internal soft-start feature to reduce the inrush current drawn during start-up. When the voltage applied on VIN pin is higher than 3V and a logic high is applied on the EN pin, the device starts operation and ramps up the reference voltage to 1.229V in 2ms. The 2ms soft-start time ensures the output voltage to ramp slowly, which effectively reduces the inrush current during start-up.

Over-Current Protection

The peak current mode control of SGM6607A provides inherent over-current protection. The LS FET is turned off when the peak current reaches the current limit threshold of 1.2A (TYP), and the LS FET is not turned on again until the next clock cycle.

Under-Voltage Lockout (UVLO)

The SGM6607A implements input under-voltage lockout feature. When the input voltage falls below the falling threshold of 2.2V (TYP), the device stops switching and turns off the internal FET.

Thermal Shutdown

A thermal shutdown function is implemented to prevent damage caused by excessive heat and power dissipation. Once a junction temperature of +150°C (TYP) is exceeded, the device is shut down. The device is released from shutdown automatically when the junction temperature decreases by 15°C.

Enable and Shutdown

The SGM6607A implements the EN function to turn on/off the device. A logic signal higher than 1.6V turns on the device, and logic signal lower than 0.4V turns off the device. The EN pin integrates an internal 500kΩ (TYP) pull-down resistor to prevent the device from false turn-on when the EN pin is left floating.

APPLICATION INFORMATION

Program Output Voltage

The output voltage of SGM6607A is configured via a resistive divider connected to the FB pin. Use Equation 1 to program the output voltage. R_1 is the top feedback resistor and R_2 is the bottom feedback resistor.

$$V_{OUT} = 1.229V \times \left(\frac{R_1}{R_2} + 1 \right)$$

$$R_1 = R_2 \times \left(\frac{V_{OUT}}{1.229V} - 1 \right) \quad (1)$$

Due to the leakage current of the resistor divider, the resistance of R_2 should be no less than 10k Ω .

Switch Duty Cycle

The Boost converter's duty cycle determines the Boost ratio available for the device. The SGM6607A implements maximum switch duty cycle (D) of 95% (TYP), the duty cycle and input/output voltage relationship is shown in Equation 2. Care should be taken to ensure that the maximum duty cycle limit is not reached.

$$D = \frac{V_{OUT} - V_{IN}}{V_{OUT}} \quad (2)$$

The SGM6607A also implements minimum on-time of 80ns (TYP), which is related to minimum duty cycle. In light load condition, the device enters pulse-skipping mode, and the device operates with minimum duty cycle in this mode.

Inductor Selection

Inductor is an essential element for current DC/DC switch mode power supplies regardless of topology. Inductor serves as the energy storage element for power conversion. Inductance and saturation current of inductor are two most important criterions for inductor selection. For general design guidance, the selected inductance should provide a peak to peak ripple current that is around 30% of the average inductor current at full load and nominal input voltage. The average inductor current for a Boost converter is the input current. Equation 3 shows the calculation of inductance selection, where f_{SW} is the switching frequency and ΔI_L is the inductor ripple current.

$$L = \frac{V_{CC}}{\Delta I_L \times f_{SW}} \times \left(1 - \frac{V_{IN}}{V_O} \right) \quad (3)$$

The selected inductor should have a saturation current

rating higher than the 1.2A (TYP) current limit of SGM6607A.

The inductor also affects the close loop response of the DC/DC converter. The recommended inductor ranges from 6.8 μ H to 22 μ H. Since the SGM6607A implements built-in slope compensation to prevent sub-harmonic oscillation, inductance lower than 6.8 μ H might results in insufficient slope compensation, which ultimately results in unstable operation.

Compensation Capacitor Selection

The control loop's compensation is done externally on SGM6607A, which provides design flexibility for various input and output voltage combinations. A series RC connected on the COMP pin forms a pole and zero, in addition to the inherent pole of current mode control, set the close loop frequency response of the device.

Equations 4 to 8 indicate the calculation of corresponding poles and zeros of Boost frequency response. Equation 4 presents the dominant pole formed with C_{COMP} . Equation 5 presents the output load pole, where R_{OUT} is the equivalent load resistance. Equation 6 presents the right half plane zero, the designed loop response cross over frequency should be less than 1/5th of the right half plane zero frequency to ensure enough phase margin at cross over frequency. Equation 7 presents the phase Boost zero. Lastly, Equation 8 presents the DC gain of the system, where G_{EA} can be found in the Electrical Characteristics table, R_{SENSE} is 200m Ω .

$$f_{P1} = \frac{1}{2\pi \times 140M\Omega \times C_{COMP}} \quad (4)$$

$$f_{P2} = \frac{2}{2\pi \times R_{OUT} \times C_{OUT}} \quad (5)$$

$$f_{RHPZ} = \frac{R_{OUT}}{2\pi \times L} \times \left(\frac{V_{IN}}{V_{OUT}} \right)^2 \quad (6)$$

$$f_z = \frac{1}{2\pi \times R_{COMP} \times C_{COMP}} \quad (7)$$

$$A = \frac{1.229V}{V_{OUT}} \times G_{EA} \times 140M\Omega \times \frac{V_{IN}}{V_{OUT} \times R_{SENSE}} \times R_{OUT} \times \frac{1}{2} \quad (8)$$

The recommended value for R_{COMP} and C_{COMP} is 4.99k Ω and 10nF to ensure stable operation and acceptable load transient response, C_{COMP} can be tuned in the range of 1nF to 22nF.

APPLICATION INFORMATION (continued)**Schottky Diode Selection**

The external rectification diode selection is critical to ensure device performance. A high speed and low forward voltage drop diode is recommended to improve efficiency. The average current rating of the diode should be higher than the peak load. The breakdown voltage of the selected diode should be higher than the programmed output voltage with margin, for example, a 12V output application requires a minimal of 20V breakdown voltage.

Input and Output Capacitor Selection

The output capacitors of Boost converter dictate the output voltage ripple and load transient response. Equation 9 is used to estimate the necessary capacitance to achieve desired output voltage ripple, where ΔV is the maximum allowed ripple.

$$C_{\text{MIN}} = \frac{I_{\text{O}} \times (V_{\text{OUT}} - V_{\text{CC}})}{f \times \Delta V \times V_{\text{OUT}}} \quad (9)$$

The recommended output capacitor ranges from 1 μ F to 10 μ F. Due to the DC bias nature of ceramic capacitors, care should be taken by verifying manufacture's datasheet to ensure enough effective capacitance at desired output voltage.

Boost converter's input capacitor has continuous current throughout the entire switching cycle, a 4.7 μ F ceramic capacitor is recommended to place as close as possible between the VIN pin and GND pin of the device. For applications where the SGM6607A is located far away from the input source, a 47 μ F or higher capacitance capacitor is recommended to damp the wiring harness inductance.

REVISION HISTORY

NOTE: Page numbers for previous revisions may differ from page numbers in the current version.

SEPTEMBER 2023 – REV.A.2 to REV.A.3	Page
Added SW pin pulse values in Absolute Maximum Ratings section	2
AUGUST 2022 – REV.A.1 to REV.A.2	Page
Updated I_{Q} condition in Electrical Characteristics section.....	4
Updated Figure 5 Functional Block Diagram.....	8
MAY 2022 – REV.A to REV.A.1	Page
Updated Detailed Description and Application Information sections.....	9, 10, 11
Changes from Original (APRIL 2021) to REV.A	Page
Changed from product preview to production data.....	All

PACKAGE OUTLINE DIMENSIONS

TDFN-2x2-6AL

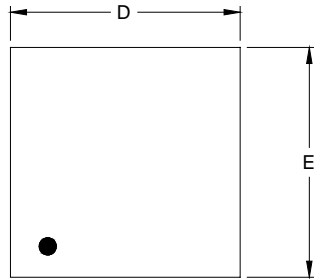

TOP VIEW

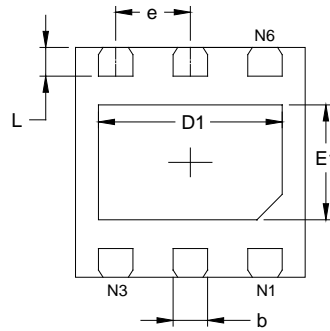

BOTTOM VIEW

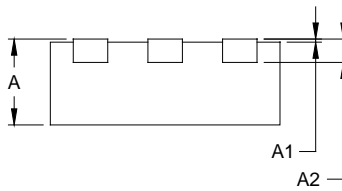

SIDE VIEW

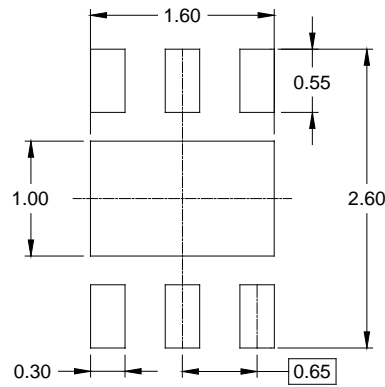

RECOMMENDED LAND PATTERN (Unit: mm)

Symbol	Dimensions In Millimeters		Dimensions In Inches	
	MIN	MAX	MIN	MAX
A	0.700	0.800	0.028	0.031
A1	0.000	0.050	0.000	0.002
A2	0.203 REF		0.008 REF	
D	1.900	2.100	0.075	0.083
D1	1.500	1.700	0.059	0.067
E	1.900	2.100	0.075	0.083
E1	0.900	1.100	0.035	0.043
b	0.250	0.350	0.010	0.014
e	0.650 BSC		0.026 BSC	
L	0.174	0.326	0.007	0.013

NOTE: This drawing is subject to change without notice.

PACKAGE INFORMATION

PACKAGE OUTLINE DIMENSIONS

TSOT-23-6

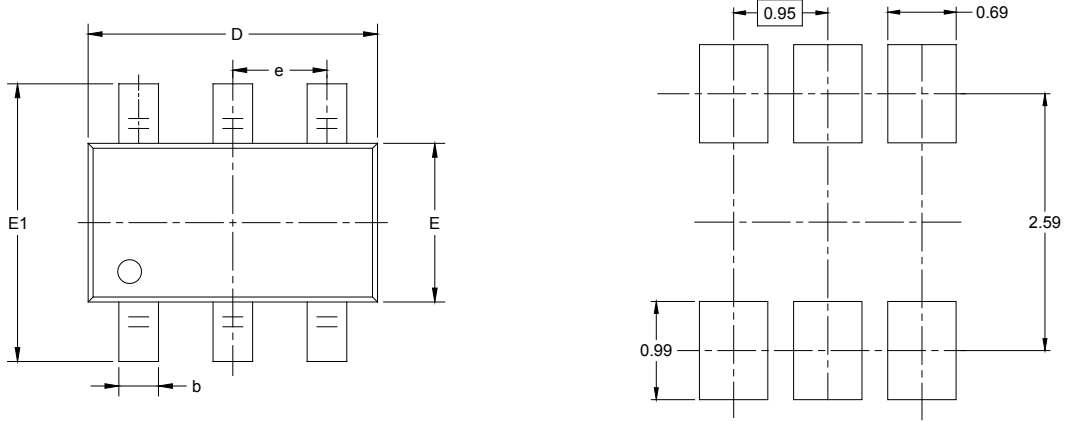

RECOMMENDED LAND PATTERN (Unit: mm)

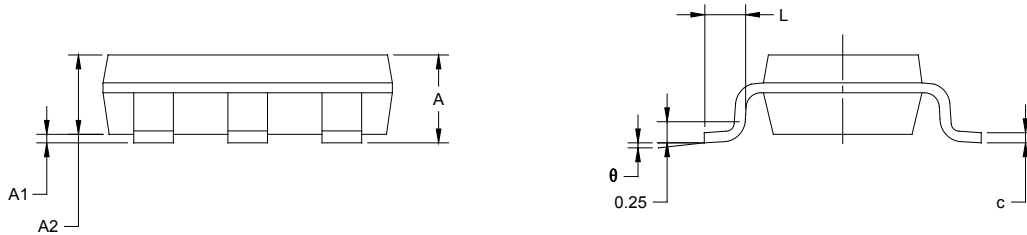

Symbol	Dimensions In Millimeters		Dimensions In Inches	
	MIN	MAX	MIN	MAX
A		1.000		0.043
A1	0.000	0.100	0.000	0.004
A2	0.700	0.900	0.028	0.039
b	0.300	0.500	0.012	0.020
c	0.080	0.200	0.003	0.008
D	2.850	2.950	0.112	0.116
E	1.550	1.650	0.061	0.065
E1	2.650	2.950	0.104	0.116
e	0.950 BSC		0.037 BSC	
L	0.300	0.600	0.012	0.024
θ	0°	8°	0°	8°

TAPE AND REEL INFORMATION

REEL DIMENSIONS



TAPE DIMENSIONS



NOTE: The picture is only for reference. Please make the object as the standard.

KEY PARAMETER LIST OF TAPE AND REEL

Package Type	Reel Diameter	Reel Width W1 (mm)	A0 (mm)	B0 (mm)	K0 (mm)	P0 (mm)	P1 (mm)	P2 (mm)	W (mm)	Pin1 Quadrant
TDFN-2×2-6AL	7"	9.5	2.30	2.30	1.10	4.0	4.0	2.0	8.0	Q2
TSOT-23-6	7"	9.5	3.20	3.10	1.10	4.0	4.0	2.0	8.0	Q3

DD0001

PACKAGE INFORMATION

CARTON BOX DIMENSIONS



NOTE: The picture is only for reference. Please make the object as the standard.

KEY PARAMETER LIST OF CARTON BOX

Reel Type	Length (mm)	Width (mm)	Height (mm)	Pizza/Carton
7" (Option)	368	227	224	8
7"	442	410	224	18

DD0002