

GENERAL DESCRIPTION

The SGM706 microprocessor supervisory circuit reduces the complexity and number of components required to monitor power supply and monitor microprocessor activity. It significantly improves system reliability and accuracy compared to separate ICs or discrete components.

The SGM706 provides power supply monitoring circuitry that generates a reset output during power-up, power-down and brownout conditions. The reset output remains operational with V_{CC} as low as 1V. Independent watchdog monitoring circuitry is also provided. This is activated if the watchdog input has not been toggled within 1.6 seconds.

In addition, there is a 1.25V threshold detector for power-fail warning, low-battery detection, or monitoring an additional power supply. An active-low manual-reset input (\overline{MR}) is also included.

The SGM706 is available in a Green SOIC-8 package. The SGM706-S is available in Green SOIC-8 and MSOP-8 packages. They operate over an ambient temperature range of -40°C to $+85^{\circ}\text{C}$.

FEATURES

- **Precision Supply-Voltage Monitor**
 - 4.65V for SGM706-L
 - 4.40V for SGM706-M
 - 4.0V for SGM706-J
 - 3.08V for SGM706-T
 - 2.93V for SGM706-S
 - 2.63V for SGM706-R
- **Guaranteed $\overline{\text{RESET}}$ Valid at $V_{CC} = 1\text{V}$**
- **200ms Reset Pulse Width**
- **Debounced TTL/CMOS-Compatible Manual-Reset Input**
- **Independent Watchdog Timer (1.6sec) Timeout**
- **Voltage Monitor for Power-Fail or Low-Battery Warning**
- **-40°C to $+85^{\circ}\text{C}$ Operating Temperature Range**
- **SGM706 is Available in a Green SOIC-8 Package**
- **SGM706-S is Available in Green SOIC-8 and MSOP-8 Packages**

APPLICATIONS

- Computers
- Controllers
- Intelligent Instruments
- Automotive Systems
- Critical μP Power Monitoring

TYPICAL APPLICATION

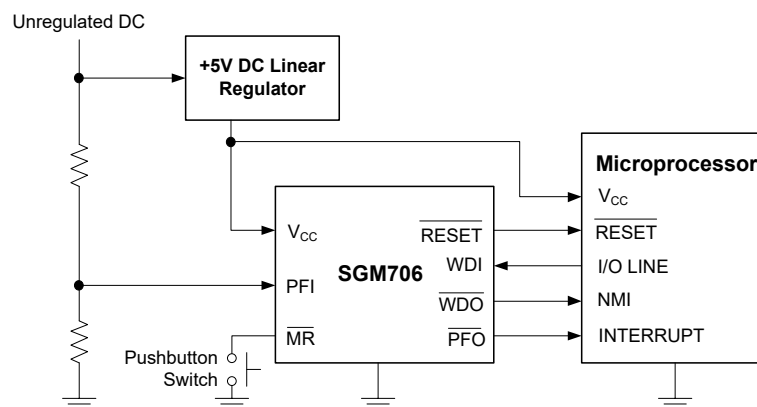

SGM706

PACKAGE/ORDERING INFORMATION

MODEL	RESET THRESHOLD (V)	PACKAGE DESCRIPTION	ORDERING NUMBER	PACKAGE MARKING	PACKAGE OPTION
SGM706	4.65	SOIC-8	SGM706-LYS8G/TR	SGM706-LYS8 XXXXX	Tape and Reel, 4000
	4.40	SOIC-8	SGM706-MYS8G/TR	SGM706-MYS8 XXXXX	Tape and Reel, 4000
	4.0	SOIC-8	SGM706-JYS8G/TR	SGM706-JYS8 XXXXX	Tape and Reel, 4000
	3.08	SOIC-8	SGM706-TYS8G/TR	SGM706-TYS8 XXXXX	Tape and Reel, 4000
	2.93	SOIC-8	SGM706-SYS8G/TR	SGM706-SYS8 XXXXX	Tape and Reel, 4000
	2.93	MSOP-8	SGM706-SYMS8G/TR	SGM706S YMS8 XXXXX	Tape and Reel, 4000
	2.63	SOIC-8	SGM706-RYS8G/TR	SGM706-RYS8 XXXXX	Tape and Reel, 4000

MARKING INFORMATION

NOTE: XXXXX = Date Code and Vendor Code.

XXXXX

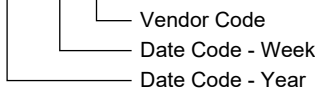

Green (RoHS & HSF): SG Micro Corp defines "Green" to mean Pb-Free (RoHS compatible) and free of halogen substances. If you have additional comments or questions, please contact your SGMICRO representative directly.

ABSOLUTE MAXIMUM RATINGS

(Typical values are at T_A = +25°C, unless otherwise noted.)

Terminal Voltage (with respect to GND)

- V_{CC} -0.3V to 6V
- All Other Inputs -0.3V to (V_{CC} + 0.3V)
- Input Current, V_{CC} 20mA
- GND 20mA
- Output Current, (all outputs) 20mA
- Junction Temperature +150°C
- Storage Temperature -65°C to +150°C
- Lead Temperature (Soldering, 10s) +260°C
- ESD Susceptibility
- HBM 4000V
- MM 300V

RECOMMENDED OPERATING CONDITIONS

Ambient Temperature Range -40°C to +85°C

OVERSTRESS CAUTION

Stresses beyond those listed in Absolute Maximum Ratings may cause permanent damage to the device. Exposure to absolute maximum rating conditions for extended periods may affect reliability. Functional operation of the device at any conditions beyond those indicated in the Recommended Operating Conditions section is not implied.

ESD SENSITIVITY CAUTION

This integrated circuit can be damaged if ESD protections are not considered carefully. SGMICRO recommends that all integrated circuits be handled with appropriate precautions. Failure to observe proper handling and installation procedures can cause damage. ESD damage can range from subtle performance degradation to complete device failure. Precision integrated circuits may be more susceptible to damage because even small parametric changes could cause the device not to meet the published specifications.

DISCLAIMER

SG Micro Corp reserves the right to make any change in circuit design, or specifications without prior notice.

SGM706

PIN CONFIGURATIONS

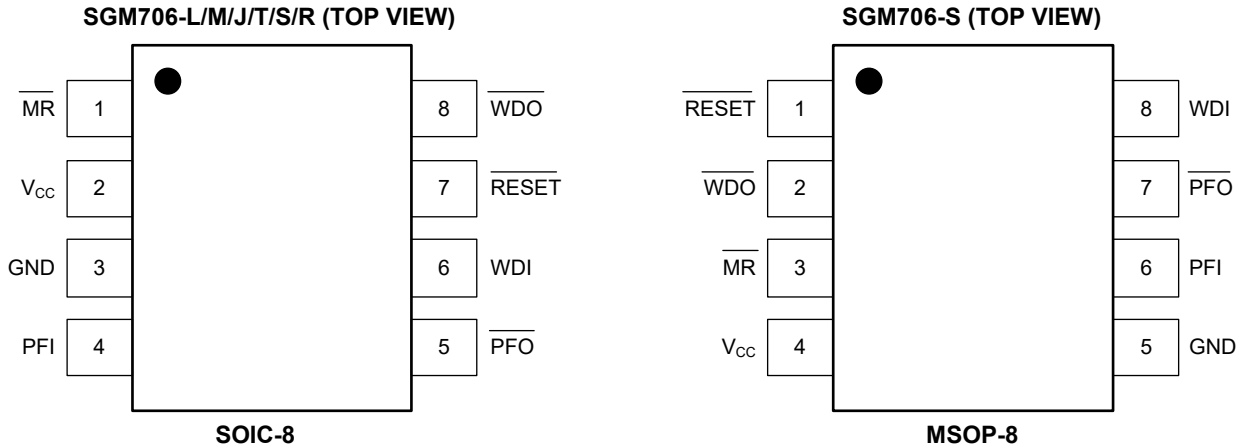

PIN DESCRIPTION

PIN		NAME	FUNCTION
SOIC-8	MSOP-8		
1	3	\overline{MR}	Manual-Reset Input triggers a reset pulse when pulled below 0.8V. This active-low input has an internal 250 μ A ($V_{CC} = +5V$) pull-up current. It can be driven from a TTL or CMOS logic line as well as shorted to ground with a switch.
2	4	V_{CC}	Power Supply Voltage that is monitored.
3	5	GND	0V Ground Reference for all signals.
4	6	PFI	Power-Fail Voltage Monitor Input. When PFI is less than 1.25V, \overline{PFO} goes low. Connect PFI to GND or V_{CC} when not used.
5	7	\overline{PFO}	Power-Fail Output goes low and sinks current when PFI is less than 1.25V; otherwise \overline{PFO} stays high.
6	8	WDI	Watchdog Input. If WDI remains high or low for 1.6sec, the internal watchdog timer runs out and \overline{WDO} goes low (BLOCK DIAGRAM). Floating WDI or connecting WDI to a high-impedance three-state buffer disables the watchdog feature. The internal watchdog timer clears whenever reset is asserted, WDI is three-stated, or WDI sees a rising or falling edge.
7	1	\overline{RESET}	Active-Low Reset Output pulses low for 200ms when triggered, and stays low whenever V_{CC} is below the reset threshold (4.65V for SGM706-L, 4.4V for SGM706-M, 4.0V for SGM706-J, 3.08V for SGM706-T and 2.93V for SGM706-S, 2.63V for SGM706-R). It remains low for 200ms after V_{CC} rises above the reset threshold or \overline{MR} goes from low to high. A watchdog timeout will not trigger \overline{RESET} unless \overline{WDO} is connected to \overline{MR} .
8	2	\overline{WDO}	Watchdog Output pulls low when the internal watchdog timer finishes its 1.6sec count and does not go high again until the watchdog is cleared. \overline{WDO} also goes low during low-line conditions. Whenever V_{CC} is below the reset threshold, \overline{WDO} stays low; however, unlike \overline{RESET} , \overline{WDO} does not have a minimum pulse width. As soon as V_{CC} rises above the reset threshold, \overline{WDO} goes high with no delay.

SGM706

ELECTRICAL CHARACTERISTICS

($V_{CC} = 4.75V$ to $5.5V$ for SGM706-L; $V_{CC} = 4.5V$ to $5.5V$ for SGM706-M; $V_{CC} = 4.07V$ to $5.5V$ for SGM706-J; $V_{CC} = 3.14V$ to $5.5V$ for SGM706-T; $V_{CC} = 2.95V$ to $5.5V$ for SGM706-S; $V_{CC} = 2.68V$ to $5.5V$ for SGM706-R; $T_A = -40^{\circ}C$ to $+85^{\circ}C$, unless otherwise noted.)

PARAMETER		CONDITIONS	MIN	TYP	MAX	UNITS
Operating Voltage Range (V_{CC})			1.0		5.5	V
Supply Current (I_{SUPPLY})				50	150	μA
Reset Threshold (V_{RT})	SGM706-L		4.5	4.65	4.75	V
	SGM706-M		4.25	4.4	4.5	
	SGM706-J		3.91	4.0	4.07	
	SGM706-T		3.02	3.08	3.14	
	SGM706-S (SOIC-8)		2.85	2.93	2.95	
	SGM706-S (MSOP-8)		2.82	2.93	2.95	
	SGM706-R		2.56	2.63	2.68	
Reset Threshold Hysteresis	SGM706-L, SGM706-M			40		mV
	SGM706-J			34		
	SGM706-T, SGM706-S			25		
	SGM706-R			22		
Reset Pulse Width (t_{RS})			120	200	280	ms
\overline{RESET} Output Voltage		$I_{SOURCE} = 800\mu A$	$0.7 \times V_{CC}$			V
		$I_{SINK} = 3.2mA$			0.4	
		$V_{CC} = 1V, I_{SINK} = 50\mu A$			0.3	
Watchdog Timeout Period (t_{WD})			1.0	1.6	2.25	sec
WDI Pulse Width (t_{WP})		$V_{IL} = 0.4V, V_{IH} = V_{CC}$	70			ns
WDI Input Threshold	Low	$V_{CC} = 5V$			0.8	V
	High	$V_{CC} = 5V$	3.5			
	Low	$V_{RST(MAX)} < V_{CC} < 3.6V$			0.8	
	High	$V_{RST(MAX)} < V_{CC} < 3.6V$	$0.7 \times V_{CC}$			
WDI Input Current		$WDI = V_{CC}$		50	150	μA
		$WDI = 0V$	-150	-50		
\overline{WDO} Output Voltage		$I_{SOURCE} = 800\mu A$	$0.7 \times V_{CC}$			V
		$I_{SINK} = 1.2mA$			0.4	
\overline{MR} Pull-Up Current		$\overline{MR} = 0V$	100		600	μA
\overline{MR} Pulse Width (t_{MR})			250			ns
\overline{MR} Input Threshold	Low	$T_A = +25^{\circ}C$			0.8	V
	High		2			
\overline{MR} to Reset Out Delay (t_{MD})					350	ns
PFI Input Threshold		$V_{CC} = 5V$	1.18	1.25	1.3	V
PFI Input Current				0.2		nA
PFO Output Voltage		$I_{SOURCE} = 800\mu A$	$0.7 \times V_{CC}$			V
		$I_{SINK} = 3.2mA$			0.4	

SGM706

FUNCTIONAL BLOCK DIAGRAM

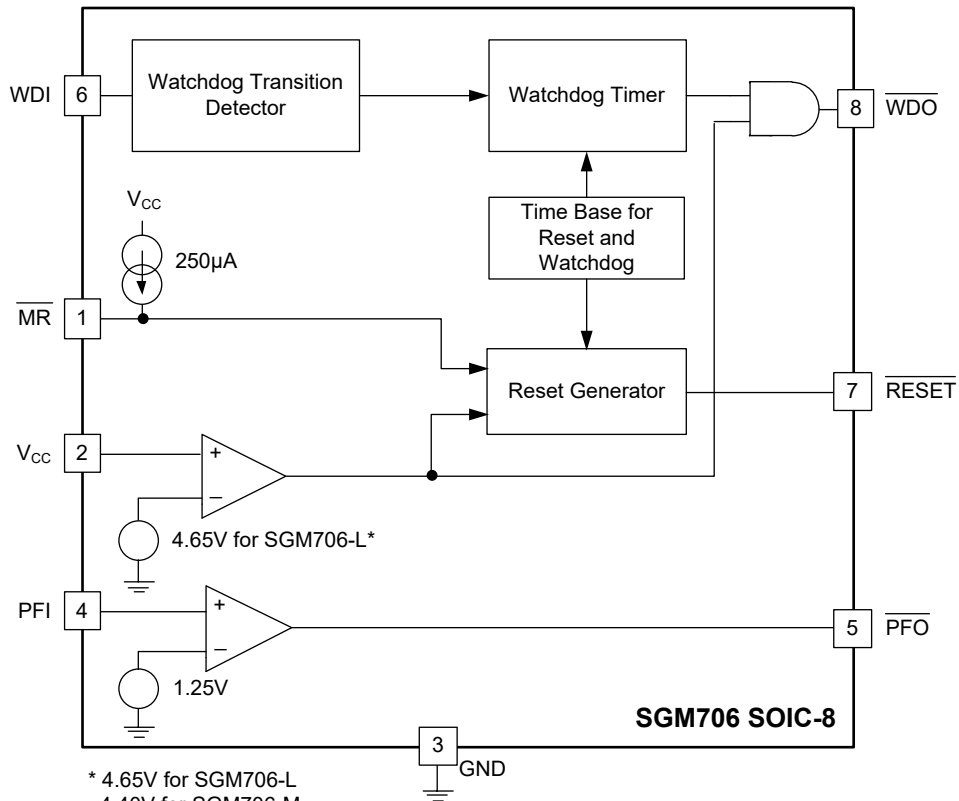

* 4.65V for SGM706-L
4.40V for SGM706-M
4.0V for SGM706-J
3.08V for SGM706-T
2.93V for SGM706-S
2.63V for SGM706-R

TYPICAL PERFORMANCE CHARACTERISTICS

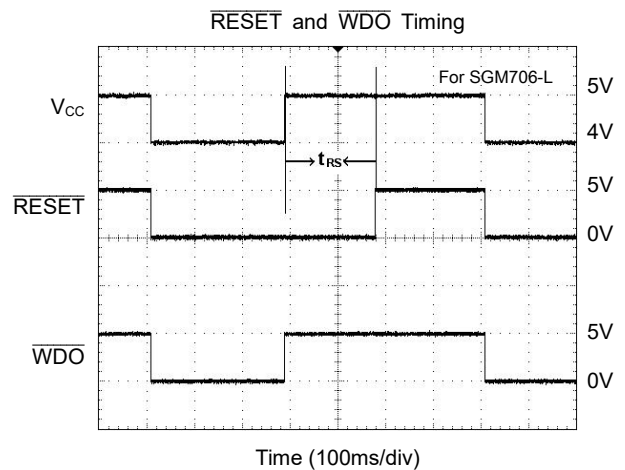
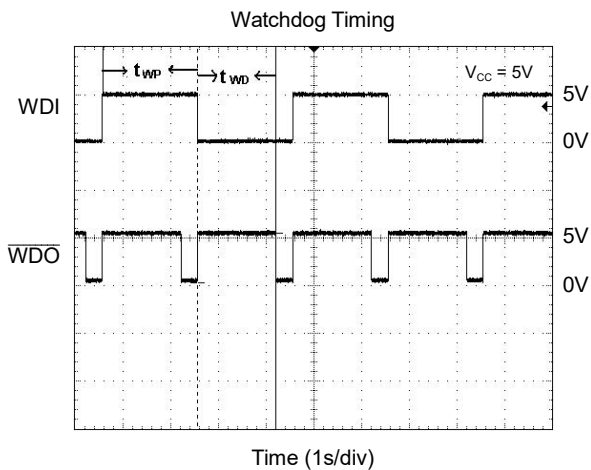
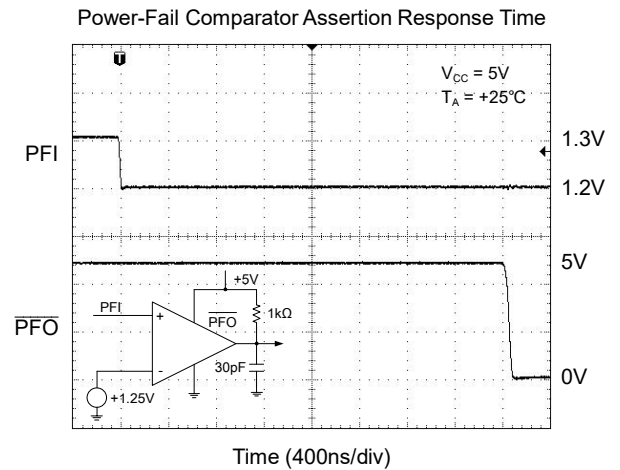
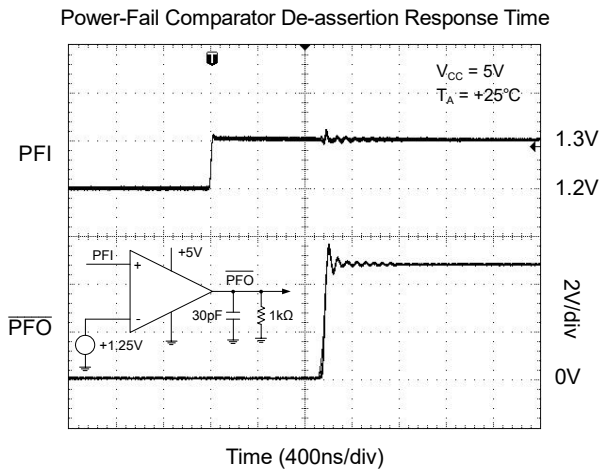
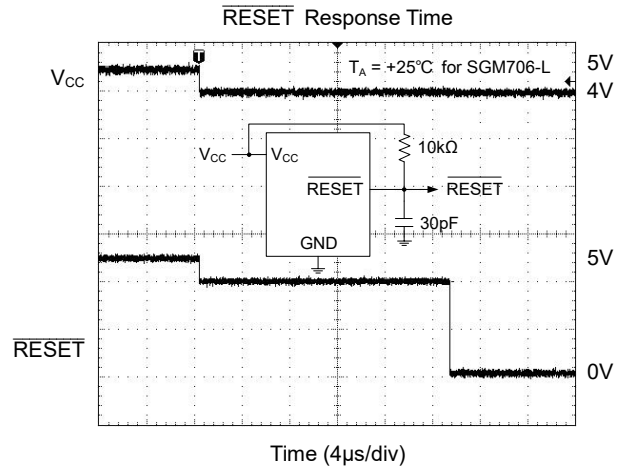
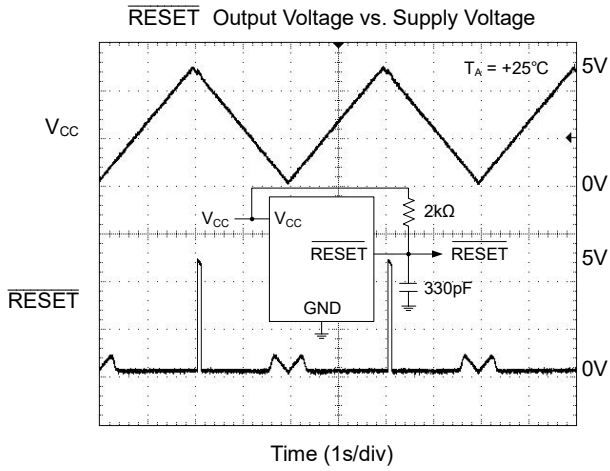

TYPICAL PERFORMANCE CHARACTERISTICS (continued)

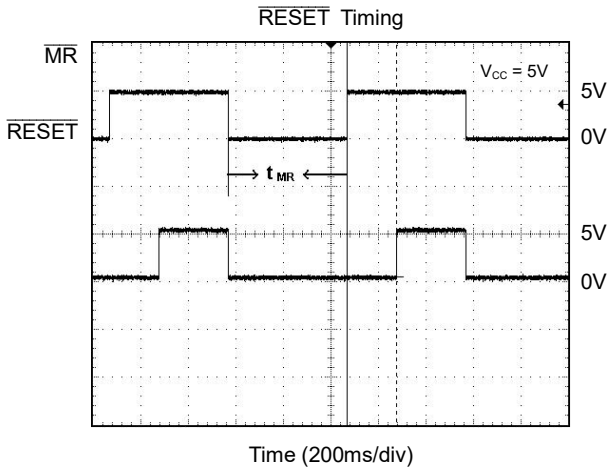

APPLICATION NOTES

Ensuring a Valid $\overline{\text{RESET}}$ Output Down to $V_{CC} = 0V$

When V_{CC} falls below 1V, the SGM706 $\overline{\text{RESET}}$ output no longer sinks current—it becomes an open circuit. High-impedance CMOS logic inputs can drift to undetermined voltages if left undriven. If a pull-down resistor is added to the $\overline{\text{RESET}}$ pin as shown in Figure 1, any stray charge or leakage currents will be drained to ground, holding $\overline{\text{RESET}}$ low. Resistor value (R1) is not critical. It should be about 100k Ω , large enough not to load $\overline{\text{RESET}}$ and small enough to pull $\overline{\text{RESET}}$ to ground.

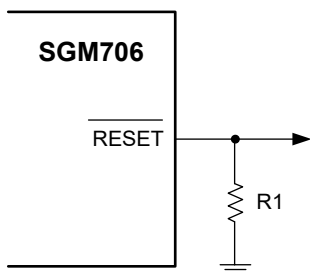

Figure 1. $\overline{\text{RESET}}$ Valid to Ground Circuit

Monitoring Voltages Other Than the Unregulated DC Input

Monitor voltages other than the unregulated DC by connecting a voltage divider to PFI and adjusting the ratio appropriately. If required, add hysteresis by connecting a resistor (with a value approximately 10 times the sum of the two resistors in the potential divider network) between PFI and $\overline{\text{PFO}}$. A capacitor between PFI and GND will reduce the power-fail circuit's sensitivity to high-frequency noise on the line being monitored. $\overline{\text{RESET}}$ can be asserted on other voltages in addition to the +5V V_{CC} line. Connect $\overline{\text{PFO}}$ to $\overline{\text{MR}}$ to initiate a $\overline{\text{RESET}}$ pulse when PFI drops below 1.25V. Figure 2 shows the SGM706 configured to assert $\overline{\text{RESET}}$ when the +5V supply falls below the reset threshold, or when the +12V supply falls below approximately 11V.

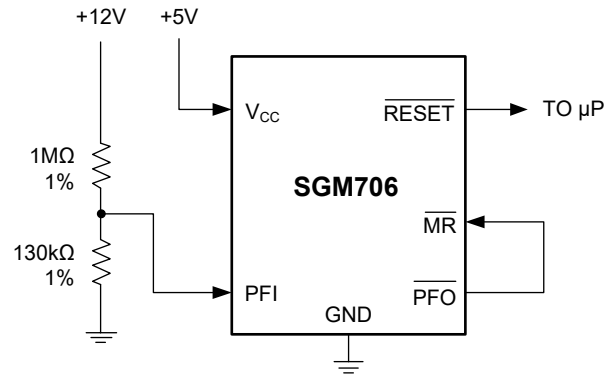
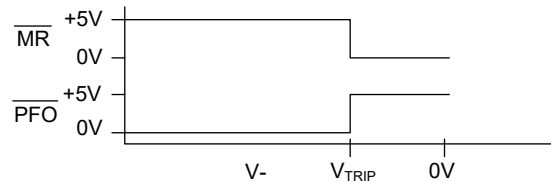
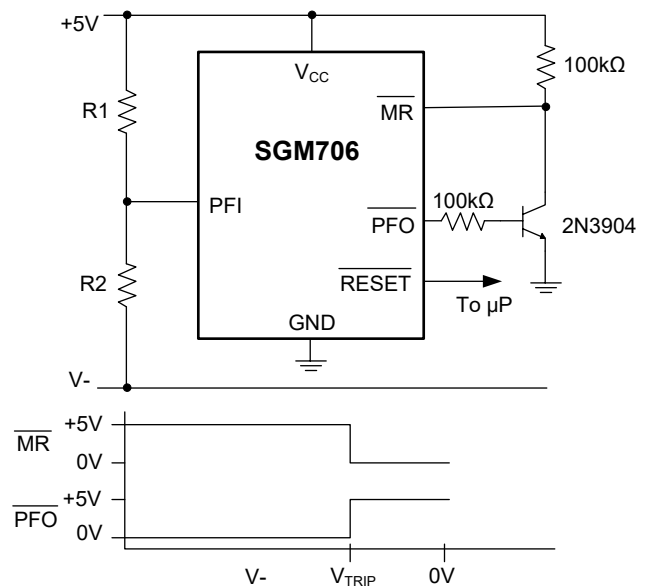

Figure 2. Monitoring Both +5V and +12V

Monitoring a Negative Voltage

The power-fail comparator can also monitor a negative supply rail (Figure 3). When the negative rail is good (a negative voltage of large magnitude), $\overline{\text{PFO}}$ is low, and when the negative rail is degraded (a negative voltage of lesser magnitude), $\overline{\text{PFO}}$ is high. By adding the resistors and transistor as shown, a high $\overline{\text{PFO}}$ triggers reset. As long as $\overline{\text{PFO}}$ remains high, the SGM706 will keep reset asserted ($\overline{\text{RESET}}$ = low, RESET = high). Note that this circuit's accuracy depends on the PFI threshold tolerance, the V_{CC} line, and the resistors.



$$\frac{5 - 1.25}{R1} = \frac{1.25 - V_{TRIP}}{R2} \quad V_{TRIP} < 0$$

Figure 3. Monitoring a Negative Voltage

SGM706

Interfacing to μ Ps with Bidirectional Reset Pins

μ Ps with bidirectional reset pins, such as the Motorola 68HC11 series, can contend with the SGM706 $\overline{\text{RESET}}$ output. If, for example, the $\overline{\text{RESET}}$ output is driven high and the Microprocessor wants to pull it low, indeterminate logic levels may result. To correct this, connect a 4.7k Ω resistor between the $\overline{\text{RESET}}$ output and the μ P reset I/O, as in Figure 4. Buffer the $\overline{\text{RESET}}$ output to other system components.

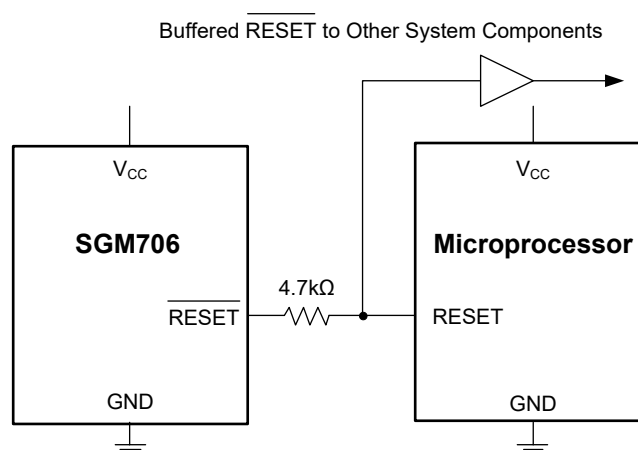

Figure 4. Interfacing to Microprocessors with Bidirectional Reset I/O

REVISION HISTORY

NOTE: Page numbers for previous revisions may differ from page numbers in the current version.

DECEMBER 2017 – REV.A.4 to REV.B	Page
Changed Electrical Characteristics section	4
AUGUST 2017 – REV.A.3 to REV.A.4	Page
SGM706-S Added MSOP-8 Package	All
MARCH 2017 – REV.A.2 to REV.A.3	Page
Changed Packing Option	2
JANUARY 2013 – REV.A.1 to REV.A.2	Page
Added Recommended Land Pattern Information	10
Added Tape and Reel Information	11, 12
MAY 2011 – REV.A to REV.A.1	Page
Updated Package Description	All
Changes from Original (APRIL 2010) to REV.A	Page
Changed from product preview to production data	All

PACKAGE OUTLINE DIMENSIONS

SOIC-8

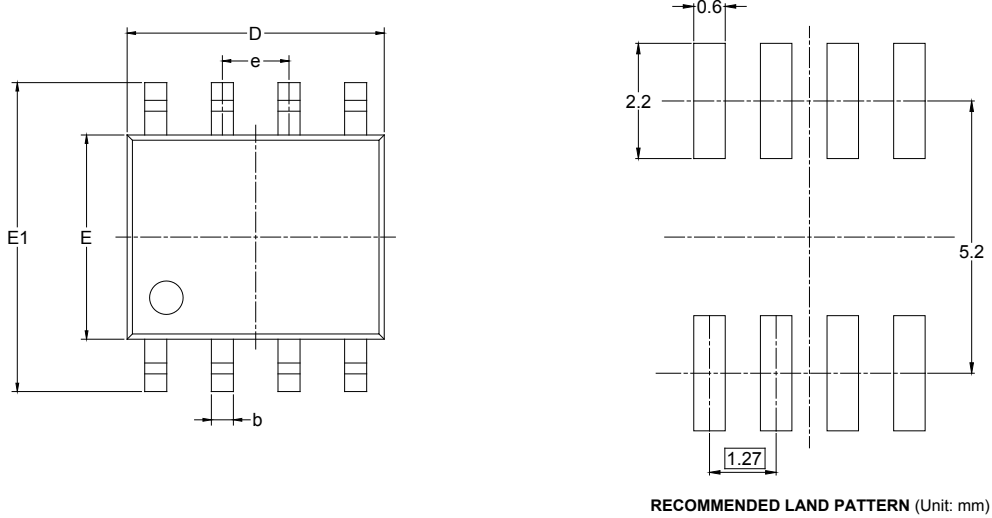

Symbol	Dimensions In Millimeters		Dimensions In Inches	
	MIN	MAX	MIN	MAX
A	1.350	1.750	0.053	0.069
A1	0.100	0.250	0.004	0.010
A2	1.350	1.550	0.053	0.061
b	0.330	0.510	0.013	0.020
c	0.170	0.250	0.006	0.010
D	4.700	5.100	0.185	0.200
E	3.800	4.000	0.150	0.157
E1	5.800	6.200	0.228	0.244
e	1.27 BSC		0.050 BSC	
L	0.400	1.270	0.016	0.050
θ	0°	8°	0°	8°

PACKAGE OUTLINE DIMENSIONS

MSOP-8

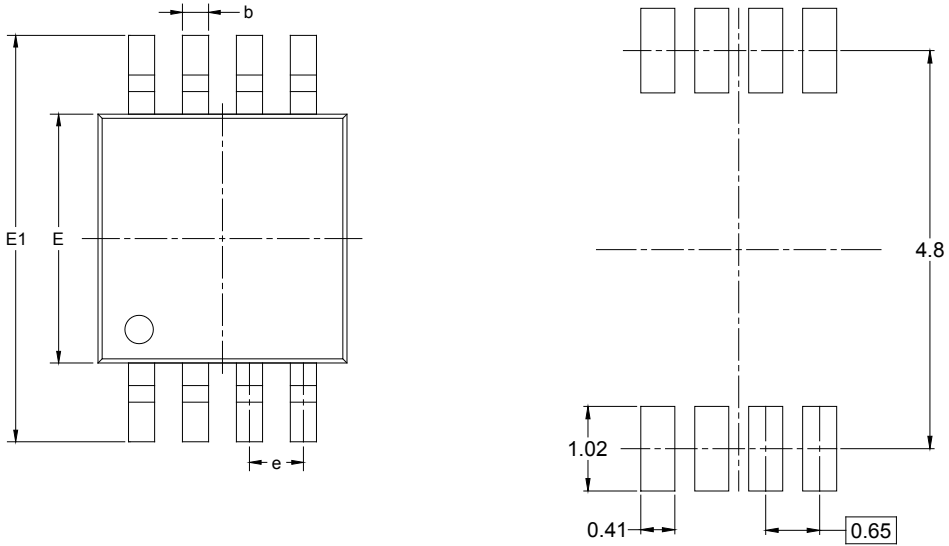

RECOMMENDED LAND PATTERN (Unit: mm)

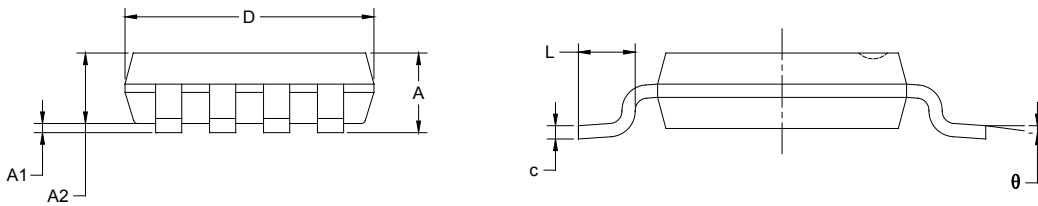

Symbol	Dimensions In Millimeters		Dimensions In Inches	
	MIN	MAX	MIN	MAX
A	0.820	1.100	0.032	0.043
A1	0.020	0.150	0.001	0.006
A2	0.750	0.950	0.030	0.037
b	0.250	0.380	0.010	0.015
c	0.090	0.230	0.004	0.009
D	2.900	3.100	0.114	0.122
E	2.900	3.100	0.114	0.122
E1	4.750	5.050	0.187	0.199
e	0.650 BSC		0.026 BSC	
L	0.400	0.800	0.016	0.031
θ	0°	6°	0°	6°

PACKAGE INFORMATION

TAPE AND REEL INFORMATION

REEL DIMENSIONS

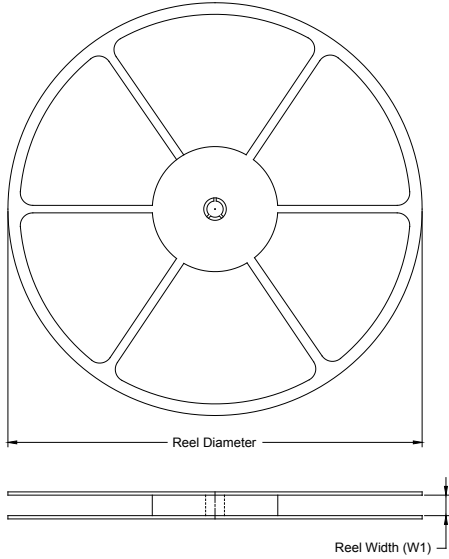

TAPE DIMENSIONS

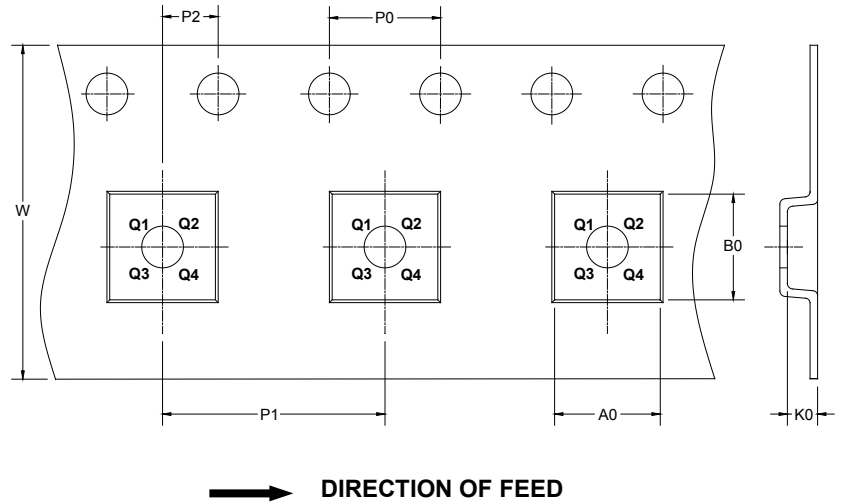

NOTE: The picture is only for reference. Please make the object as the standard.

KEY PARAMETER LIST OF TAPE AND REEL

Package Type	Reel Diameter	Reel Width W1 (mm)	A0 (mm)	B0 (mm)	K0 (mm)	P0 (mm)	P1 (mm)	P2 (mm)	W (mm)	Pin1 Quadrant
SOIC-8	13"	12.4	6.40	5.40	2.10	4.0	8.0	2.0	12.0	Q1
MSOP-8	13"	12.4	5.20	3.30	1.50	4.0	8.0	2.0	12.0	Q1

DD0001

PACKAGE INFORMATION

CARTON BOX DIMENSIONS



NOTE: The picture is only for reference. Please make the object as the standard.

KEY PARAMETER LIST OF CARTON BOX

Reel Type	Length (mm)	Width (mm)	Height (mm)	Pizza/Carton
13"	386	280	370	5

DD0002