

GENERAL DESCRIPTION

The SGM8902 is a 2Vrms to 3Vrms pop/click-free stereo line driver designed to allow the removal of the output DC-blocking capacitors for reduced component count and cost. The device is ideal for single supply electronics where size and cost are critical design parameters.

The SGM8902 is capable of driving 2Vrms into a 2.5k Ω load with 3.3V supply voltage. The device has differential inputs and uses external gain setting resistors that supports a gain range of $\pm 1V/V$ to $\pm 10V/V$. The use of external gain resistors also allows the implementation of a 2nd-order low pass filter to compliment DAC's and SOC converters. The SGM8902 has build-in shutdown control for pop/click-free on/off control.

Using the SGM8902 in audio products can reduce component count compared to traditional methods of generating a 2Vrms output. The SGM8902 doesn't require a power supply greater than 3.3V to generate a 5.6V_{PP} output, nor does the device require a split rail power supply. The SGM8902 integrates a charge pump to generate a negative supply rail that provides a clean, pop/click-free ground-biased 2Vrms output.

The SGM8902 is available in Green TSSOP-14 package. It operates over an ambient temperature range of -40°C to +85°C.

FEATURES

- **Capless Structure**
 - Eliminates Pop/Clicks
 - Eliminates Output DC-Blocking Capacitors
 - Provides Flat Frequency Response from DC to 20kHz
- **Low Noise and THD**
 - Typical SNR = 114dB
 - Typical V_N = 5.5 μ Vrms
 - Typical THD+N = 0.001% (f = 1kHz)
- **2Vrms Output Voltage into 2.5k Ω Load with 3.3V Supply Voltage**
- **3Vrms Output Voltage into 2.5k Ω Load with 5V Supply Voltage**
- **Differential Input**
- **-40°C to +85°C Operating Temperature Range**
- **Available in the Green TSSOP-14 Package**

APPLICATIONS

Set-Top Box
LCD TV
Blue-Ray DVD-Players
Home Theater in a Box

PACKAGE/ORDERING INFORMATION

MODEL	PACKAGE DESCRIPTION	SPECIFIED TEMPERATURE RANGE	ORDERING NUMBER	PACKAGE MARKING	PACKING OPTION
SGM8902	TSSOP-14	-40°C to +85°C	SGM8902YTS14G/TR	SGM8902 YTS14 XXXXX	Tape and Reel, 3000

NOTE: XXXXX = Date Code and Vendor Code.

Green (RoHS & HSF): SG Micro Corp defines "Green" to mean Pb-Free (RoHS compatible) and free of halogen substances. If you have additional comments or questions, please contact your SGMICRO representative directly.

ABSOLUTE MAXIMUM RATINGS

Supply Voltage..... -0.3V to 6V
 Input Voltage..... $V_{SS} - 0.3V$ to $V_{DD} + 0.3V$
 Minimum Load Impedance (R_L)600Ω
 EN to GND.....-0.3V to $V_{DD} + 0.3V$
 Junction Temperature+150°C
 Storage Temperature Range.....-65°C to +150°C
 Lead Temperature (Soldering, 10s)+260°C
 ESD Susceptibility
 HBM..... 6000V
 MM..... 300V
 CDM 1000V

RECOMMENDED OPERATING CONDITIONS

Supply Voltage Range3V to 5.5V
 Operating Temperature Range-40°C to +85°C

OVERSTRESS CAUTION

Stresses beyond those listed may cause permanent damage to the device. Functional operation of the device at these or any other conditions beyond those indicated in the operational section of the specification is not implied. Exposure to absolute maximum rating conditions for extended periods may affect reliability.

ESD SENSITIVITY CAUTION

This integrated circuit can be damaged by ESD if you don't pay attention to ESD protection. SGMICRO recommends that all integrated circuits be handled with appropriate precautions. Failure to observe proper handling and installation procedures can cause damage. ESD damage can range from subtle performance degradation to complete device failure. Precision integrated circuits may be more susceptible to damage because very small parametric changes could cause the device not to meet its published specifications.

DISCLAIMER

SG Micro Corp reserves the right to make any change in circuit design, specification or other related things if necessary without notice at any time.

TYPICAL OPERATION CIRCUIT

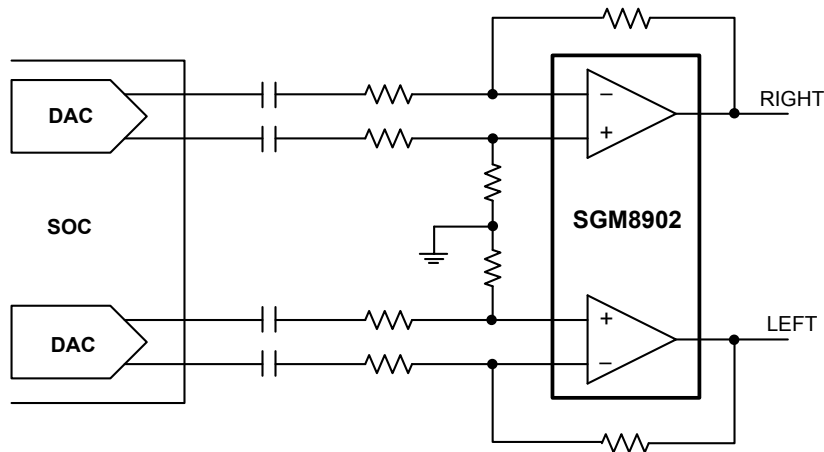

PIN CONFIGURATION

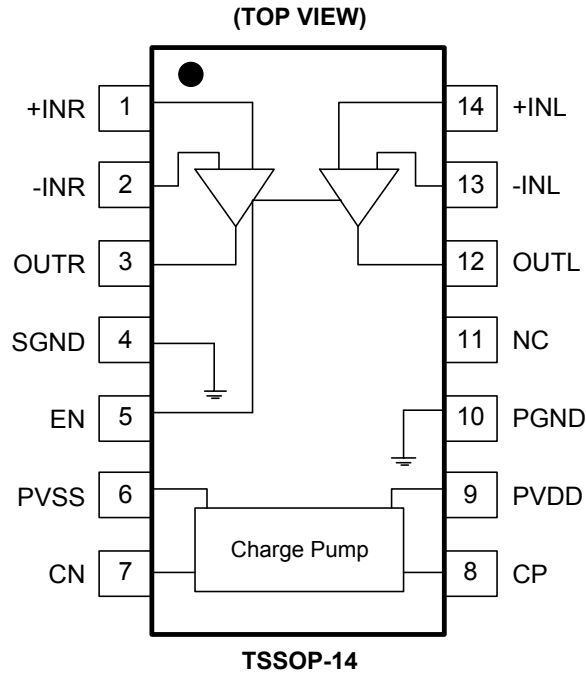

PIN DESCRIPTION

PIN	NAME	FUNCTION
1	+INR	Right Channel OPAMP Positive Input.
2	-INR	Right Channel OPAMP Negative Input.
3	OUTR	Right Channel OPAMP Output.
4	SGND	Signal Ground.
5	EN	Enable Input. Active high.
6	PVSS	Negative Supply Voltage Output.
7	CN	Charge Pump Flying Capacitor Negative Terminal.
8	CP	Charge Pump Flying Capacitor Positive Terminal.
9	PVDD	Positive Supply.
10	PGND	Power Ground.
11	NC	No Internal Connection.
12	OUTL	Left Channel OPAMP Output.
13	-INL	Left Channel OPAMP Negative Input.
14	+INL	Left Channel OPAMP Positive Input.

ELECTRICAL CHARACTERISTICS

(T_A = +25°C, unless otherwise noted.)

PARAMETER	CONDITIONS	MIN	TYP	MAX	UNITS
ELECTRICAL CHARACTERISTICS					
DC Supply Voltage (V _{DD})		3		5.5	V
Output Offset Voltage (V _{OS})	V _{DD} = 3V to 5V		1.2	5	mV
Power Supply Rejection Ratio (PSRR)	V _{DD} = 3V to 5V		97		dB
High-Level Output Voltage (V _{OH})	V _{DD} = 3.3V, R _L = 2.5kΩ	3.18			V
Low-Level Output Voltage (V _{OL})	V _{DD} = 3.3V, R _L = 2.5kΩ			-3.05	V
High-Level Input Current (EN) (I _{IH})	V _{DD} = 5V, V _I = V _{DD}			1	μA
Low-Level Input Current (EN) (I _{IL})	V _{DD} = 5V, V _I = 0V			1	μA
Supply Current (I _{DD})	V _{DD} = 3.3V, No load, EN = V _{DD}		10.5	14.5	mA
	V _{DD} = 5V, No load, EN = V _{DD}		11.3	15.5	
	Shutdown mode, V _{DD} = 3V to 5V		0.13	0.18	
OPERATING CHARACTERISTICS (V _{DD} = 3.3V, R _L = 2.5kΩ, C _{PUMP} = C _{PVSS} = 1μF, C _{IN} = 10μF, R _{IN} = 10kΩ, R _{FB} = 20kΩ.) ⁽¹⁾					
Output Voltage (Outputs in Phase) (V _O)	THD = 1%, V _{DD} = 3.3V, f = 1kHz	2.05			Vrms
	THD = 1%, V _{DD} = 5V, f = 1kHz	3.05			
	THD = 1%, V _{DD} = 5V, f = 1kHz, R _L = 100kΩ	3.1			
Total Harmonic Distortion Plus Noise (THD+N)	V _O = 2Vrms, f = 1kHz		0.001		%
Crosstalk	V _O = 2Vrms, f = 1kHz		113		dB
Output Current Limit (I _O)	V _{DD} = 3.3V		20		mA
Input Resistor Range (R _{IN})			10		kΩ
Feedback Resistor Range (R _{FB})			20		kΩ
Slew Rate			10		V/μs
Maximum Capacitive Load			220		pF
Noise Output Voltage (V _N)	A-weighted, BW = 20kHz		5.5		μVrms
Signal to Noise Ratio (SNR)	V _O = 3Vrms, THD+N = 0.1%, BW = 20kHz, A-weighted		114		dB
Unity Gain Bandwidth (G _{BW})			7.8		MHz
Open-Loop Voltage Gain (A _{VO})			120		dB
Charge Pump Frequency (F _{CP})		330	450	560	kHz
EN PIN					
Input High Voltage (V _{INH})	EN	1.2			V
Input Low Voltage (V _{INL})	EN			0.6	V

NOTE:

1. For C_{PUMP}, C_{PVSS}, C_{IN}, R_{IN} and etc, please refer to the TYPICAL APPLICATION CIRCUIT on page 7.

TYPICAL PERFORMANCE CHARACTERISTICS

$V_{DD} = 3.3V$, $T_A = +25^\circ C$, $R_L = 2.5k\Omega$, $C_{PUMP} = C_{PVSS} = 1\mu F$, $C_{IN} = 10\mu F$, $R_{IN} = 10k\Omega$, $R_{FB} = 20k\Omega$, unless otherwise noted.

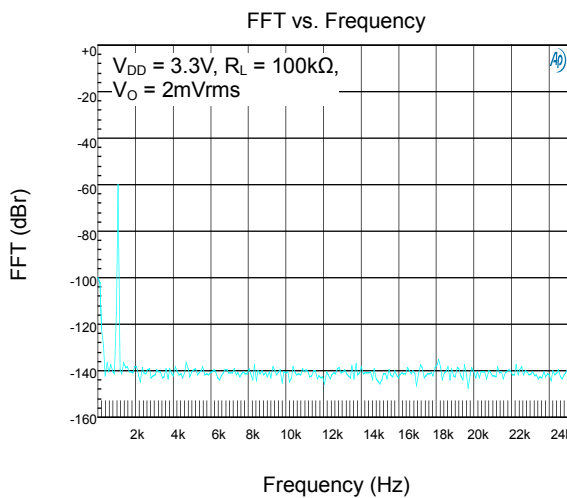
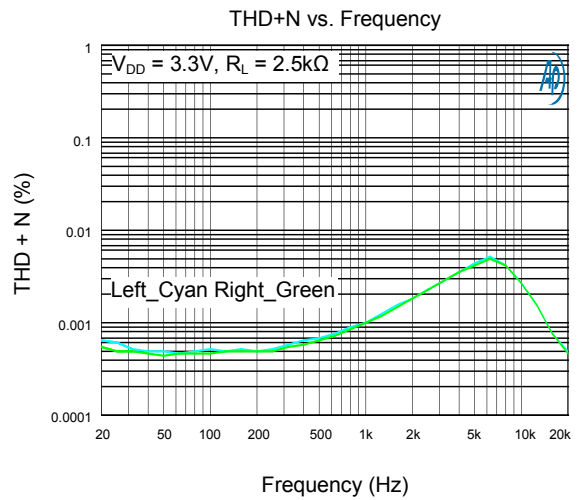
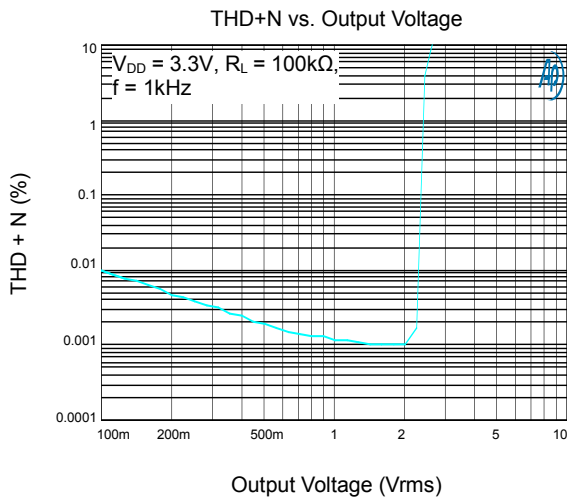
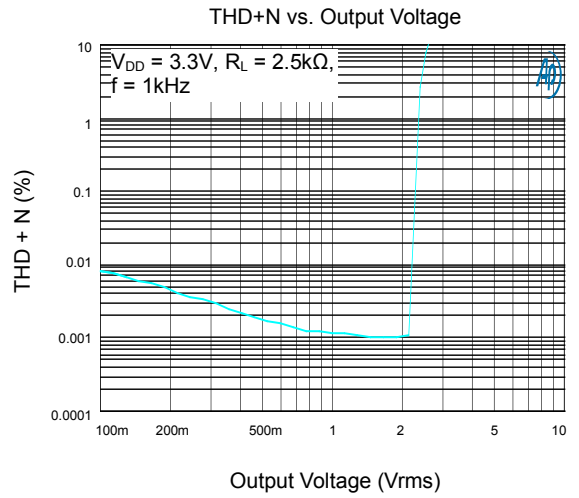
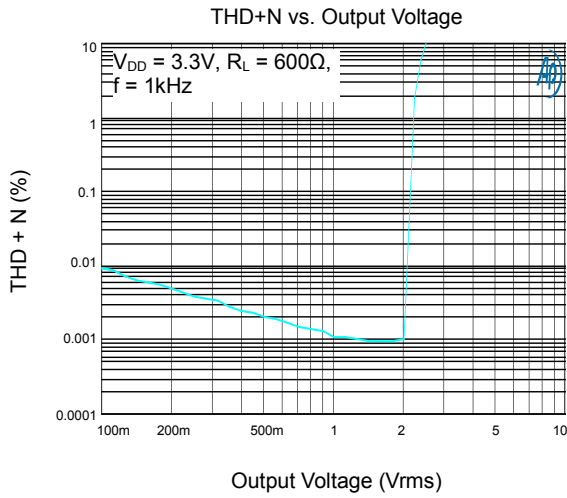

TYPICAL PERFORMANCE CHARACTERISTICS (continued)

$V_{DD} = 3.3V$, $T_A = +25^\circ C$, $R_L = 2.5k\Omega$, $C_{PUMP} = C_{PVSS} = 1\mu F$, $C_{IN} = 10\mu F$, $R_{IN} = 10k\Omega$, $R_{FB} = 20k\Omega$, unless otherwise noted.

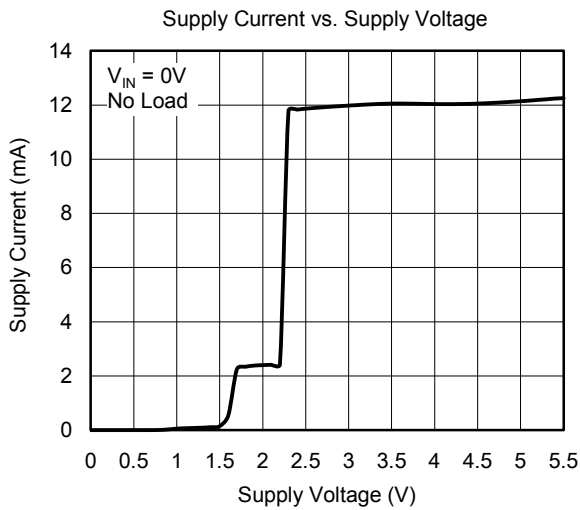
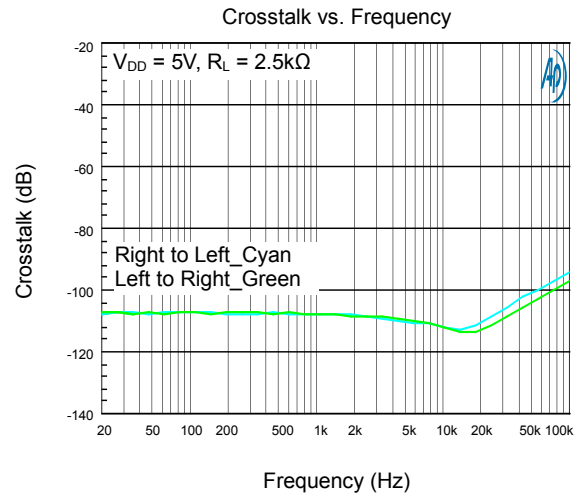
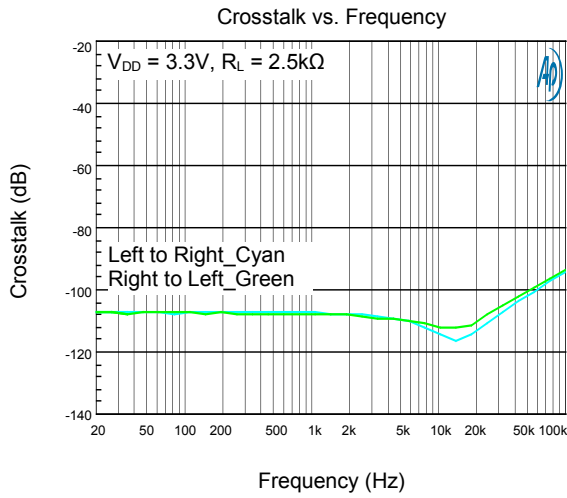

TYPICAL APPLICATION CIRCUIT

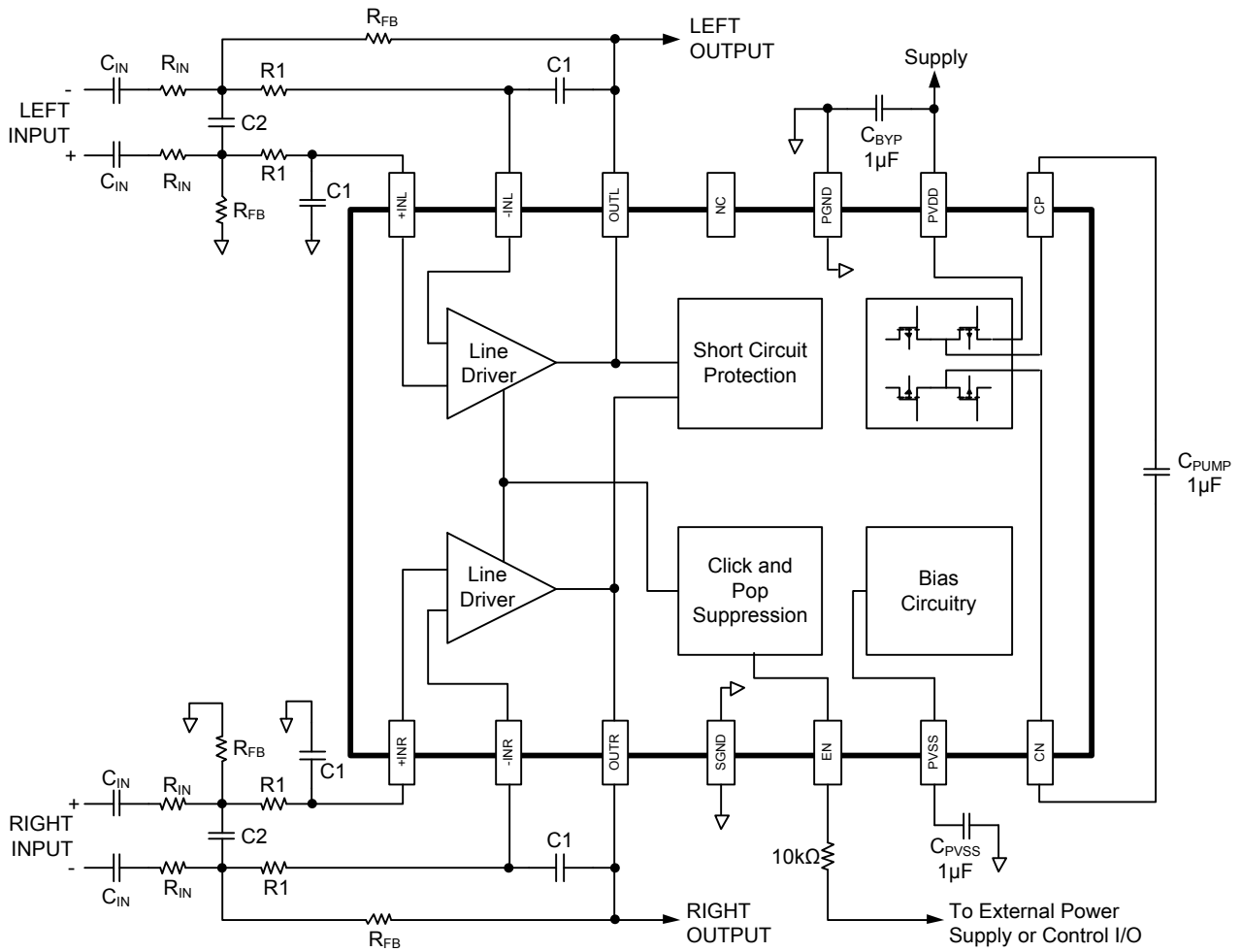

NOTES:

1. In order to get good performance, it's important to select the right C_{PUMP} , C_{PVSS} and C_{BYP} in application. All tests are performed with circuit set up with X5R and X7R capacitors. Capacitors having high dissipative loss, such as Y5V capacitor, may cause performance degradation and unexpected system behavior.
2. A 10kΩ resistor is recommended to be put between EN pin and external power supply or control I/O.

APPLICATION INFORMATION

Decoupling Capacitors

The SGM8902 is a capless line driver amplifier that requires adequate power supply decoupling to ensure that the noise and total harmonic distortion (THD) are low. A good low equivalent-series-resistance (ESR) ceramic capacitor, typically 1µF, placed as close as possible to the device V_{DD} lead, works best. Placing this decoupling capacitor close to the SGM8902 is important for the performance of the amplifier. For filtering lower frequency noise signals, a 10µF or larger capacitor placed near the audio power amplifier would also help, but it is not required in most applications because of the high PSRR of this device.

Gain Setting Resistors Ranges

The gain setting resistors, R_{IN} and R_{FB}, must be chosen so that noise, stability and input capacitor size of the SGM8902 are kept within acceptable limits. Voltage gain is defined as R_{FB} divided by R_{IN}.

Selecting values that are too low demands a large input AC coupling capacitor, C_{IN}. Selecting values that are too high increases the noise of the amplifier. Table 1 lists the recommended resistor values for different gain settings.

Table 1. Recommended Resistor Values

INPUT RESISTOR VALUE, R _{IN}	FEEDBACK RESISTOR VALUE, R _{FB}	DIFFERENTIAL INPUT GAIN	INVERTING INPUT GAIN	NON INVERTING INPUT GAIN
22kΩ	22kΩ	1.0V/V	-1.0V/V	2.0V/V
20kΩ	30kΩ	1.5V/V	-1.5V/V	2.5V/V
33kΩ	68kΩ	2.1V/V	-2.1V/V	3.1V/V
10kΩ	100kΩ	10.0V/V	-10.0V/V	11.0V/V

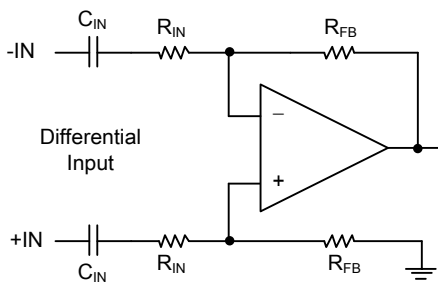

Figure 1. Differential Input

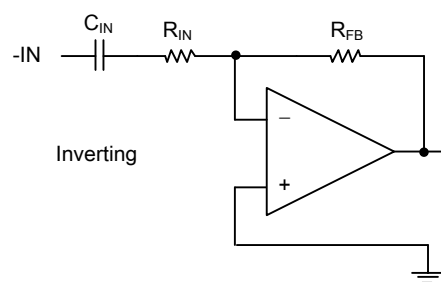

Figure 2. Inverting

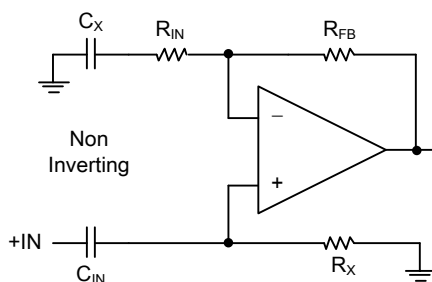

Figure 3. Non-Inverting

APPLICATION INFORMATION (continued)

Input-Blocking Capacitors

DC input-blocking capacitors are required to be added in series with the audio signal into the input pins of the SGM8902. These capacitors block the DC portion of the audio source and allow the SGM8902 inputs to be properly biased to provide maximum performance. The input blocking capacitors also limit the DC-gain to one, limiting the DC-offset voltage at the output.

These capacitors form a high-pass filter with the input resistor, R_{IN} . The cutoff frequency is calculated using Equation 1. For this calculation, the capacitance used is the input-blocking capacitor and the resistance is the input resistor chosen from Table 1, then the frequency and/or capacitance can be determined when one of the two values are given.

$$f_{c_{IN}} = \frac{1}{2\pi R_{IN} C_{IN}} \quad \text{or} \quad C_{IN} = \frac{1}{2\pi f_{c_{IN}} R_{IN}} \quad (1)$$

Using the SGM8902 as 2nd-Order Filter

Several audio DACs used today require an external low-pass filter to remove out of band noise. This is possible with the SGM8902 as it can be used like a standard OPAMP.

Several filter topologies can be implemented both single-endedly and differentially. In Figure 4, a Multi Feedback (MFB), with differential input and single-ended input is shown.

An AC coupling capacitor to remove DC-content from the source is shown. It serves to block any DC-content from the source and lowers the DC-gain to one, helping reducing the output DC-offset to minimum.

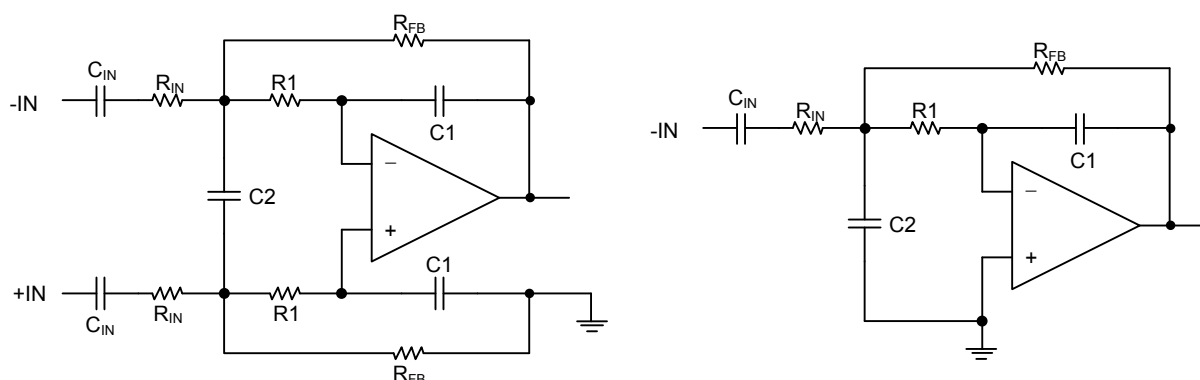

Figure 4. 2nd-Order Active Low Pass Filter

The resistor values should be kept low to obtain low noise, but should also be high enough to get a small size AC coupling cap. With the proposed values, 33k Ω , 68k Ω , or 100k Ω , an SNR of 114dB can be achieved with a small 1 μ F input AC coupling capacitor.

Pop-Free Power-Up

Pop-free power-up is ensured by keeping the \overline{SD} (EN) (shutdown pin) low during power supply ramp up and down. The EN pin should be kept low until the input AC coupling capacitors are fully charged before asserting the EN pin high. This way proper precharge of the AC coupling is performed, and pop-free power-up is achieved. Figure 5 illustrates the preferred sequence.

APPLICATION INFORMATION (continued)

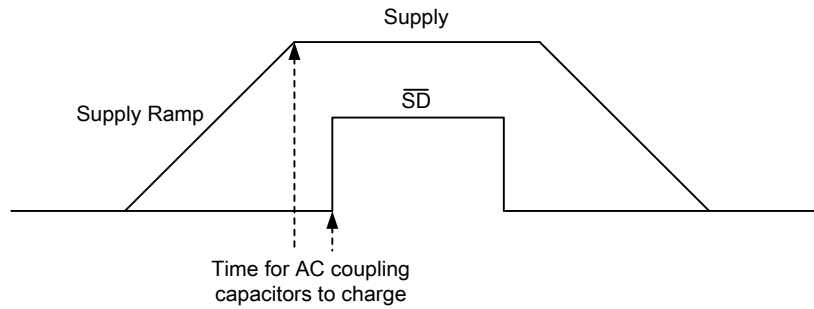

Figure 5. Power-Up Sequence

Capacitive Load

The SGM8902 has the ability to drive large capacitive load up to 220pF directly, and larger capacitive loads can be accepted by adding a series resistor of 10Ω or larger.

Gain-Setting Resistors

The gain setting resistors, R_{IN} and R_{FB} , must be placed close to the input pins to minimize the capacitive loading on these pins and to ensure maximum stability of the SGM8902.

PCB Layout Guide

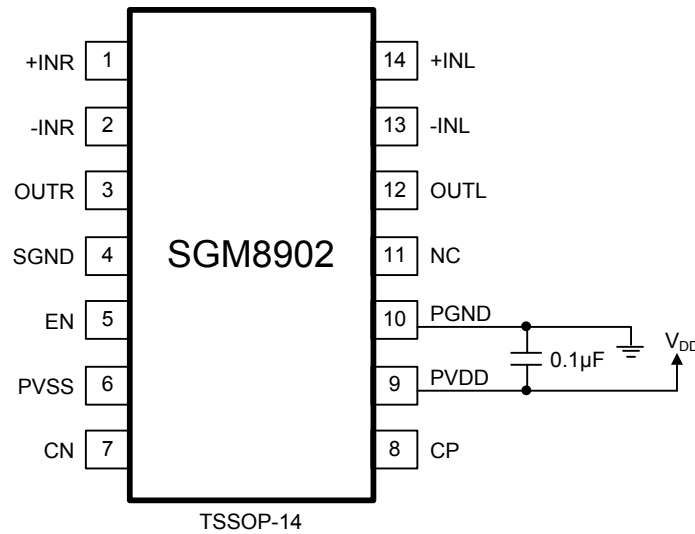

NOTE: 0.1µF decoupling capacitor must be close to PGND and PVDD pins; capacitor can be connected between PVDD and PGND pins directly and then connect PGND pin to GND layer.

APPLICATION INFORMATION (continued)

The reference PCB layout is shown in below:

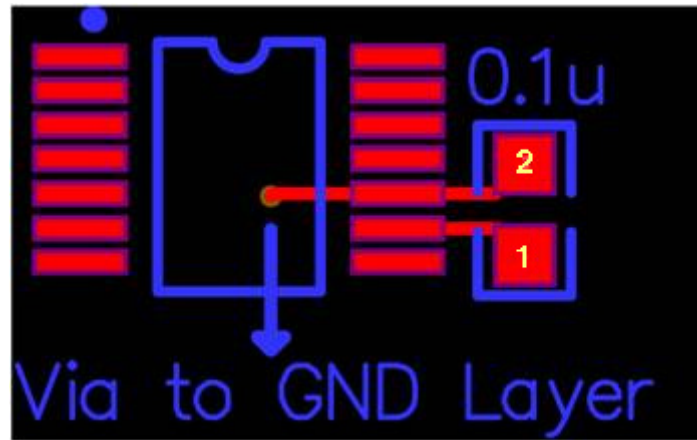

Zoomed in:

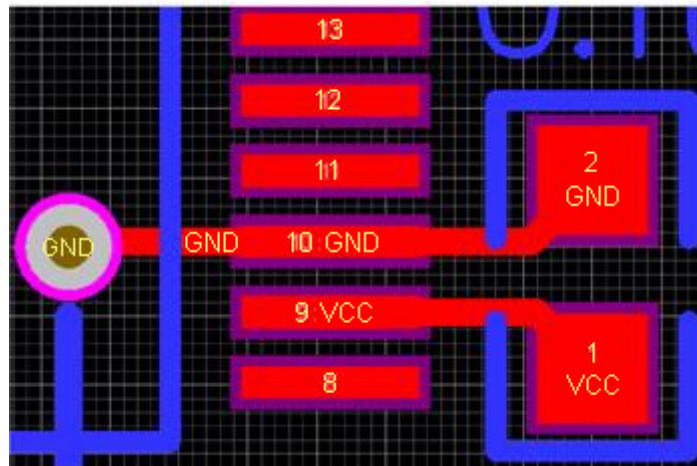

PACKAGE OUTLINE DIMENSIONS

TSSOP-14

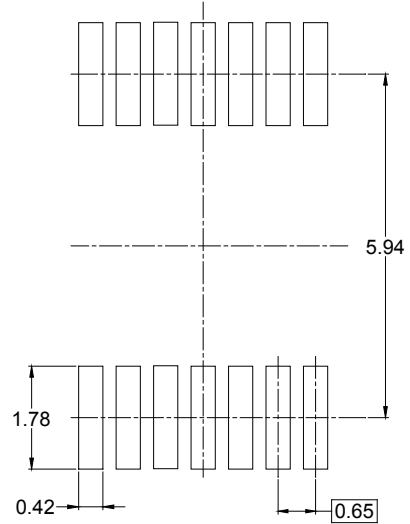
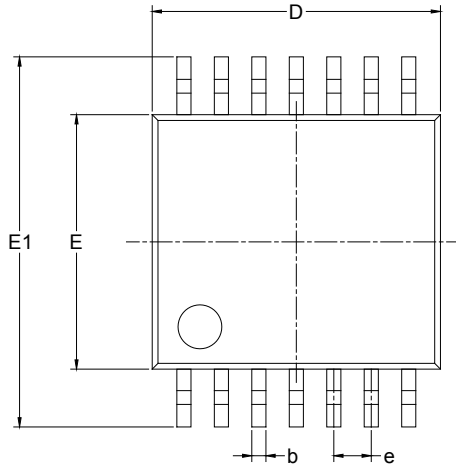

RECOMMENDED LAND PATTERN (Unit: mm)

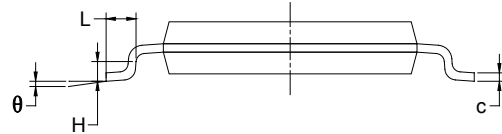
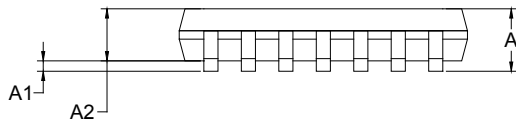

Symbol	Dimensions In Millimeters		Dimensions In Inches	
	MIN	MAX	MIN	MAX
A		1.200		0.047
A1	0.050	0.150	0.002	0.006
A2	0.800	1.050	0.031	0.041
b	0.190	0.300	0.007	0.012
c	0.090	0.200	0.004	0.008
D	4.860	5.100	0.191	0.201
E	4.300	4.500	0.169	0.177
E1	6.250	6.550	0.246	0.258
e	0.650 BSC		0.026 BSC	
L	0.500	0.700	0.02	0.028
H	0.25 TYP		0.01 TYP	
θ	1°	7°	1°	7°

TAPE AND REEL INFORMATION

REEL DIMENSIONS



TAPE DIMENSIONS



NOTE: The picture is only for reference. Please make the object as the standard.

KEY PARAMETER LIST OF TAPE AND REEL

Package Type	Reel Diameter	Reel Width W1 (mm)	A0 (mm)	B0 (mm)	K0 (mm)	P0 (mm)	P1 (mm)	P2 (mm)	W (mm)	Pin1 Quadrant
TSSOP-14	13"	12.4	6.95	5.60	1.20	4.0	8.0	2.0	12.0	Q1

000001

PACKAGE INFORMATION

CARTON BOX DIMENSIONS



NOTE: The picture is only for reference. Please make the object as the standard.

KEY PARAMETER LIST OF CARTON BOX

Reel Type	Length (mm)	Width (mm)	Height (mm)	Pizza/Carton
13"	386	280	370	5

DD0002