



SGM9119

Triple, 5th-Order, Standard Definition Video Filter Driver

PRODUCT DESCRIPTION

The SGM9119 is a low voltage, triple video amplifier with integrated reconstruction filters and input clamps. Specially suited for standard definition video signals, this device is ideal for a wide range of television and set-top box applications.

SGM9119 offers 6dB gain rail-to-rail output driver and 5th-order output reconstruction filter on all three channels. It has 8MHz -3dB bandwidth and 31.5V/ μ s slew rate. SGM9119 provides improved image quality compared with passive LC filters and discrete drivers solution. Operating from single power supply ranging from 3.3V to 5.5V and sinking a low 21mA quiescent current, the SGM9119 is ideally suited for battery powered applications.

SGM9119 can be DC-coupled or AC-coupled with input video signal, such as the output stage of DAC to eliminate out-of-band noise. The output in SGM9119 can be configured as DC- or AC-coupled output.

The SGM9119 is available in Green SOIC-8 and MSOP-8 packages. It operates over an ambient temperature range of -40°C to +85°C.

FEATURES

- Triple 5th-Order 8MHz (SD) Filters
- Transparent Input Clamping
- 6dB Output Driver Gain
- Rail-to-Rail Output
- Input Voltage Range Includes Ground
- AC- or DC-Coupled Inputs
- AC- or DC-Coupled Outputs
- Operates from 3.3V to 5.5V Power Supply
- Supply Current (7mA/Channel)
21mA Total Supply Current
- Available in Green SOIC-8 and MSOP-8 Packages
- -40°C to +85°C Operating Temperature Range

APPLICATIONS

- Cable and Satellite Set-Top Boxes
- Video Amplifiers
- Communication Devices
- Portable and Handheld Products
- Personal Video Recorders
- Video on Demand
- DVD Players

BLOCK DIAGRAM

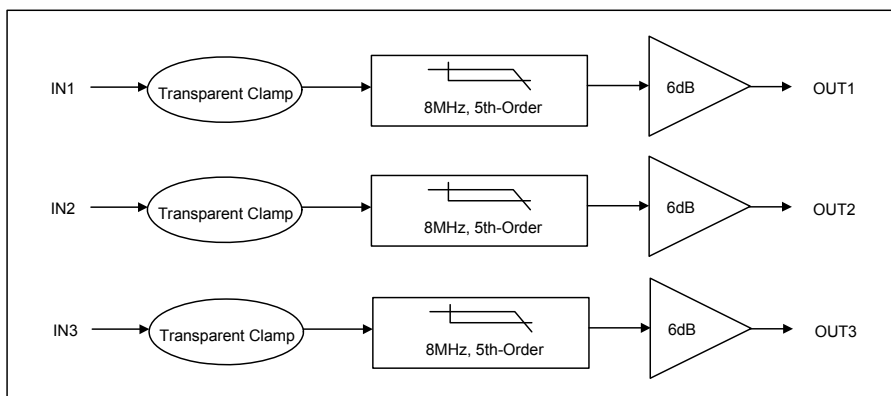

PACKAGE/ORDERING INFORMATION

ORDER NUMBER	PACKAGE DESCRIPTION	TEMPERATURE RANGE	PACKAGE OPTION	MARKING INFORMATION
SGM9119YS8G/TR	SOIC-8	-40°C to +85°C	Tape and Reel, 2500	SGM9119YS8
SGM9119YMS8G/TR	MSOP-8	-40°C to +85°C	Tape and Reel, 3000	SGM9119YMS8

PIN CONFIGURATIONS (TOP VIEW)

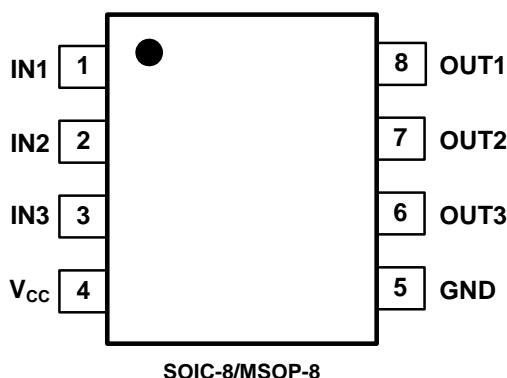

PIN DESCRIPTION

PIN	NAME	FUNCTION
1	IN1	Video Input. Channel 1.
2	IN2	Video Input. Channel 2.
3	IN3	Video Input. Channel 3.
4	V _{CC}	Power Supply.
5	GND	Ground.
6	OUT3	Filtered Output. Channel 3.
7	OUT2	Filtered Output. Channel 2.
8	OUT1	Filtered Output. Channel 1.

ABSOLUTE MAXIMUM RATINGS

Supply Voltage, V _{CC} to GND.....	6V
Input Voltage.....	GND - 0.3V to V _{CC} + 0.3V
Storage Temperature Range	-65°C to +150°C
Junction Temperature	150°C
Operating Temperature Range.....	-40°C to +85°C
Lead Temperature Range (Soldering 10 sec)	260°C
ESD Susceptibility	
HBM.....	8000V
MM.....	400V

NOTE:

Stresses beyond those listed under “Absolute Maximum Ratings” may cause permanent damage to the device. These are stress ratings only, and functional operation of the device at these or any other conditions beyond those indicated in the operational sections of the specifications is not implied. Exposure to absolute maximum rating conditions for extended periods may affect device reliability.

CAUTION

This integrated circuit can be damaged by ESD if you don’t pay attention to ESD protection. SGMICRO recommends that all integrated circuits be handled with appropriate precautions. Failure to observe proper handling and installation procedures can cause damage. ESD damage can range from subtle performance degradation to complete device failure. Precision integrated circuits may be more susceptible to damage because very small parametric changes could cause the device not to meet its published specifications.

SGMICRO reserves the right to make any change in circuit design, specification or other related things if necessary without notice at any time. Please contact SGMICRO sales office to get the latest datasheet.

ELECTRICAL CHARACTERISTICS: $V_{CC} = 5.0V$

(At $R_L = 150\Omega$ connected to GND, $V_{IN} = 1V_{PP}$ and $C_{IN} = 0.1\mu F$, all outputs AC-coupled with $220\mu F$, referenced to 400kHz, unless otherwise noted.)

PARAMETER	CONDITIONS	TEMP	MIN	TYP	MAX	UNITS
INPUT CHARACTERISTICS						
Output Level Shift Voltage (V_{OLS})	$V_{IN} = 0V$, No load	+25°C		386	572	mV
		-40°C to +85°C			670	
Input Voltage Clamp (V_{CLAMP})	$I_{IN} = -3.5mA$	+25°C	-220	-104		mV
		-40°C to +85°C	-300			
Clamp Charge Current	$V_{IN} = V_{CLAMP} - 100mV$	+25°C	-6	-4.7		mA
		-40°C to +85°C	-7.8			
Voltage Gain (A_v)	$R_L = 150\Omega$	+25°C	5.7	6	6.4	dB
		-40°C to +85°C	5.4		6.6	
OUTPUT CHARACTERISTICS						
Output Voltage High Swing	$V_{IN} = 3V$, $R_L = 150\Omega$ to GND	+25°C	4.3	4.74		V
		-40°C to +85°C	4.2			
POWER SUPPLY						
Operating Voltage Range		+25°C	3.3		5.5	V
Power Supply Rejection Ratio (PSRR)	$V_{CC} = 3.5V$ to $5.0V$	+25°C	52	61		dB
		-40°C to +85°C	47			
Quiescent Current (I_Q)	$V_{IN} = 0V$	+25°C		21	26	mA
		-40°C to +85°C			30	
AC PERFORMANCE						
-0.1dB Bandwidth	$R_L = 150\Omega$	+25°C		5.56		MHz
-3dB Bandwidth	$R_L = 150\Omega$	+25°C		7.56		MHz
Filter Response (Normalized Gain)	$f_{IN} = 27MHz$	+25°C		46.77		dB
Slew Rate	2V Output step, 80% to 20%	+25°C		31.5		V/ μs
Differential Gain (DG)	PAL DC-coupled	+25°C		0.57		%
	PAL AC-coupled	+25°C		0.86		%
Differential Phase (DP)	PAL DC-coupled	+25°C		0.85		°
	PAL AC-coupled	+25°C		1.41		°
Group Delay Variation (D/DT)	Difference between 400kHz and 6.5MHz	+25°C		31.2		ns
Crosstalk (channel-to-channel)	$f = 1MHz$	+25°C		-60		dB
Fall Time	2V Output step, 80% to 20%	+25°C		38.1		ns
Rise Time	2V Output step, 80% to 20%	+25°C		38.7		ns

TYPICAL PERFORMANCE CHARACTERISTICS

At $V_{CC} = 5V$, $T_A = +25^{\circ}C$, $R_L = 150\Omega$, all outputs AC-coupled with $220\mu F$, unless otherwise noted.

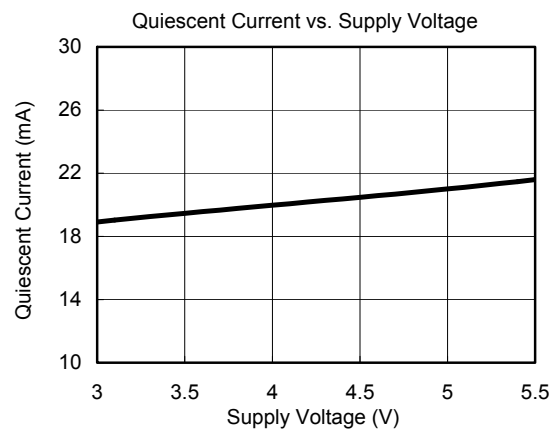
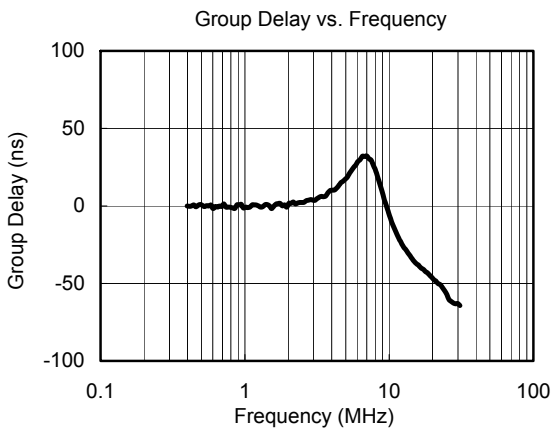
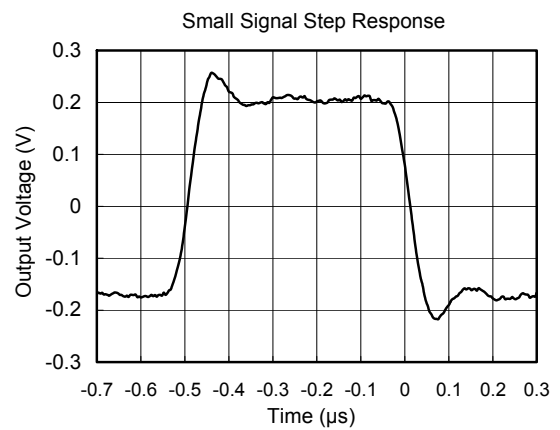
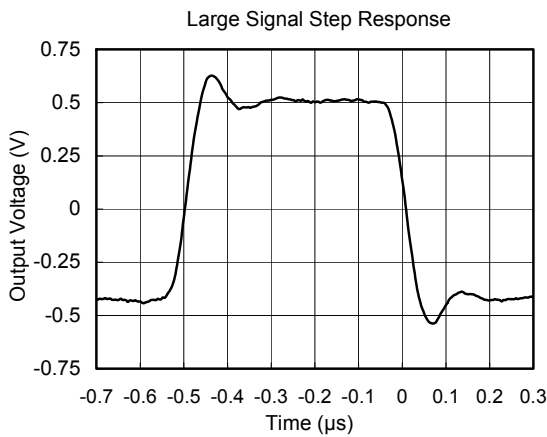
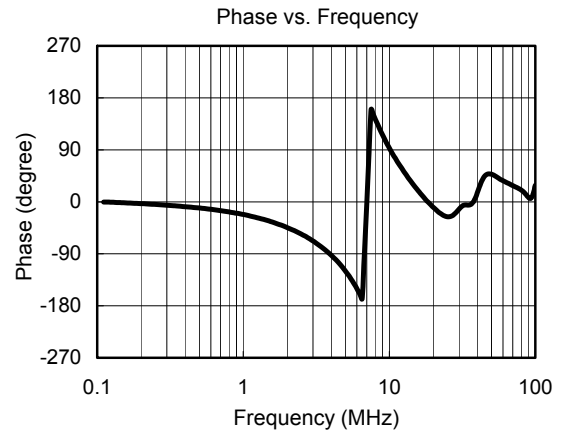
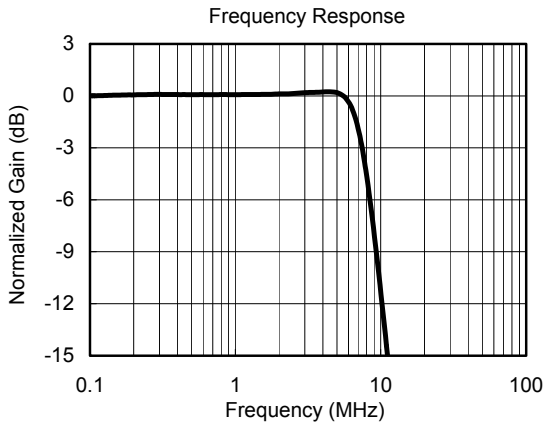

TYPICAL PERFORMANCE CHARACTERISTICS

At $V_{CC} = 5V$, $T_A = +25^{\circ}C$, $R_L = 150\Omega$, all outputs AC-coupled with $220\mu F$, unless otherwise noted.

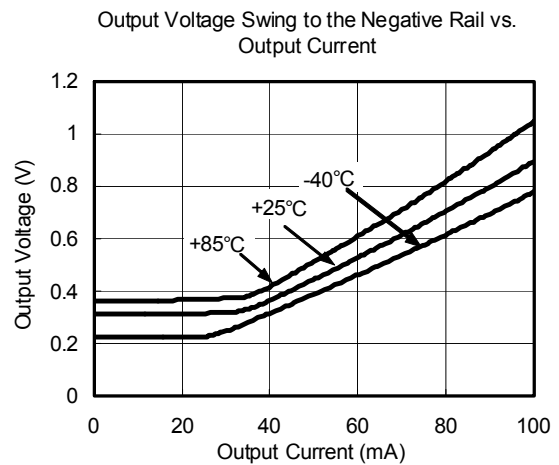
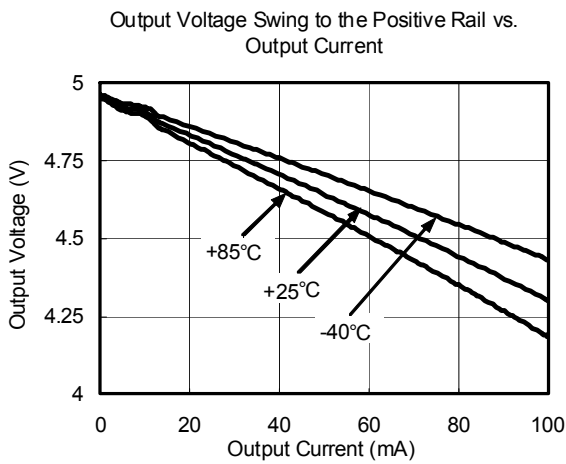
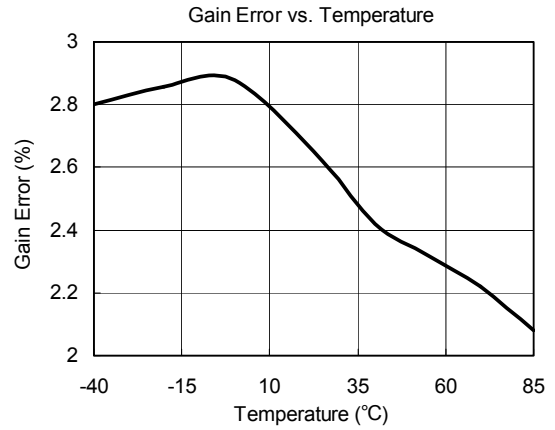
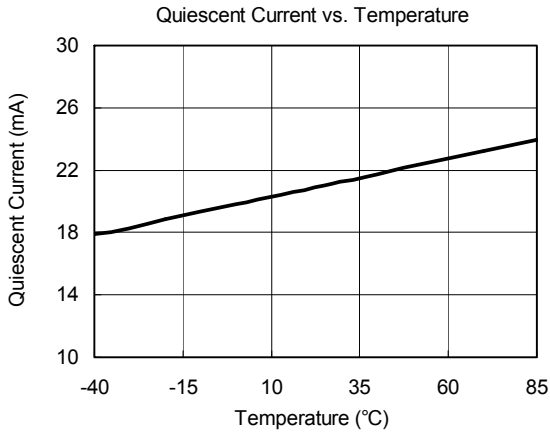

APPLICATION INFORMATION

Functional Description

SGM9119 operates from a single 3.3V to 5V supply. In application, SGM9119 is a fully integrated solution for filtering and buffering SDTV signals in front of video decoder or behind video encoder. For example, SGM9119 can replace three passive LC filters and three amplifier drivers at CVBS and S-video output side in set-top box and DVD player. This solution can help reduce PCB size and production cost, and it also improves video signal performance comparing with traditional design using discrete components. SGM9119 features a DC-coupled input buffer, a 5-pole low-pass filter to eliminate out-of-band noise of video encoder, and a gain of 6dB in the output amplifier to drive 75Ω load. The AC- or DC-coupled input buffer eliminates sync crush, droop, and field tilt. The output of SGM9119 also can be DC-coupled or AC-coupled.

Input Considerations

Besides AC coupling, the SGM9119 inputs also can be DC-coupled. In DC coupling application, no input coupling capacitors are needed because the amplitude of input video signal from DAC includes ground and extends up to 1.4V, and SGM9119 can be directly connected to the output of a single-supply, current-output DAC without any external bias network. In applications where DAC's output level exceeds the range from 0V to 1.4V, or SGM9119 is driven by an unknown external source or a SCART switch which has its own clamping circuit, AC coupling is needed.

Output Considerations

The SGM9119 outputs can be DC-coupled or AC-coupled. When input is 0V, the SGM9119 output voltage is 401mV typically. In DC coupling design, one 75Ω resistor is used to connect SGM9119's output pin with external load directly, and this serial back-termination resistor is used to match the impedance of the transmission line between SGM9119 and external load to cancel the signal reflection. The SGM9119 outputs can sink and source current allowing the device to be AC-coupled with external load. In AC coupling, at least 220μF capacitor will be used in order to eliminate field tilt.

Power-Supply Bypassing and Layout

Correct power supply bypassing is very important for optimizing video performance in design. One 0.1μF and one 10μF capacitors are always used to bypass V_{CC} pin of SGM9119. Place these two capacitors as close to the SGM9119 supply pin as possible. A large ground plane is also needed to ensure optimum performance. The input and output termination resistors should be placed as close to the related pins of SGM9119 as possible to avoid performance degradation. The PCB traces at the output side should have 75Ω characteristic impedance in order to match the 75Ω characteristic impedance of the cable connecting external load. In design, keep the board trace at the inputs and outputs of the SGM9119 as short as possible to minimize the parasitic stray capacitance and noise pickup.

TYPICAL APPLICATION DIAGRAM

The following schematic in Figure 2 is normally used for AC-coupled output and DC-coupled input with DAC which has an output voltage range from 0V to 1.4V. AC-coupled output offers slightly lower power dissipation and high ESD protection ability.

The schematic in Figure 1 is also popular in design.

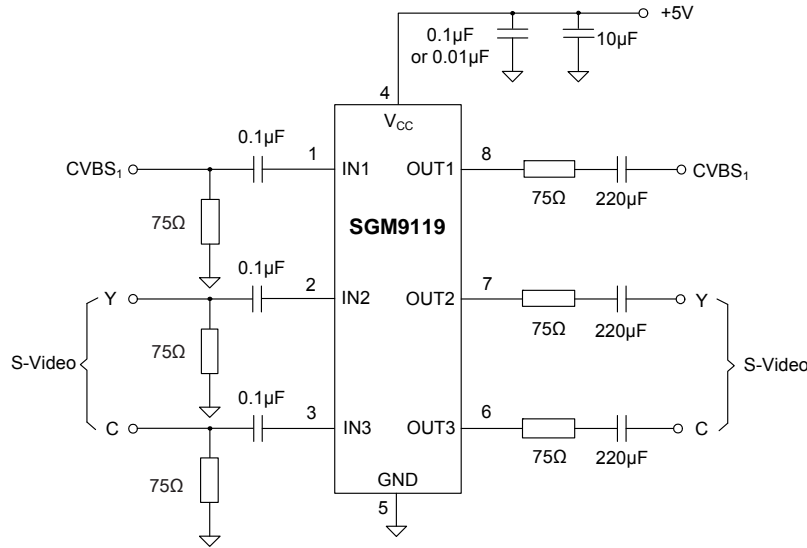

Figure 1. AC Coupling Application Schematic

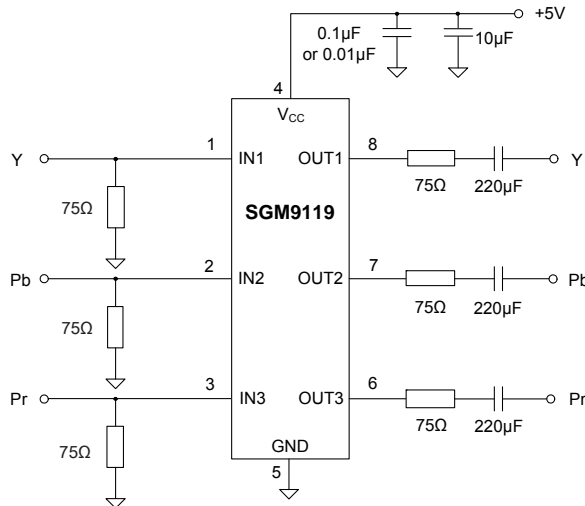

Figure 2. Input DC Coupling and Output AC Coupling Application Schematic

NOTE:

1. Power supply V_{CC} must be sequenced on first before input video signals.

PACKAGE OUTLINE DIMENSIONS

SOIC-8

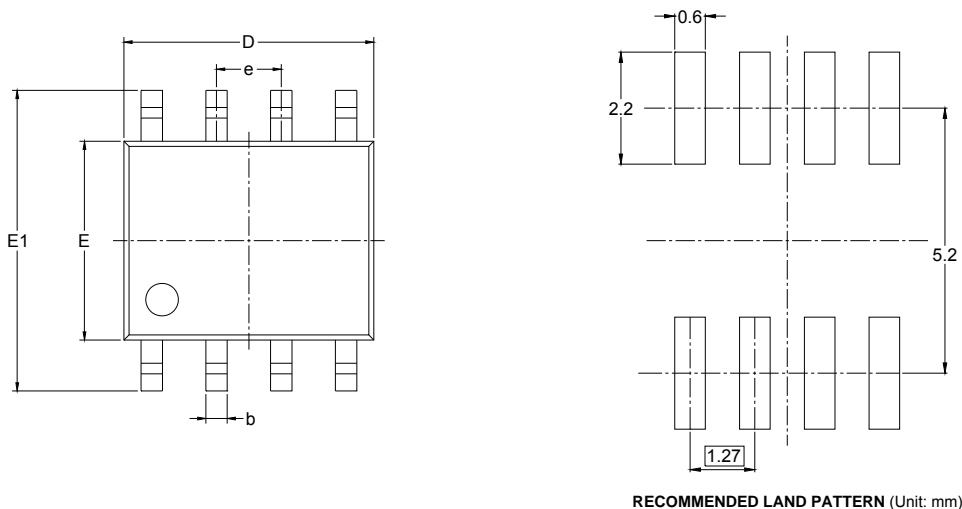

Symbol	Dimensions In Millimeters		Dimensions In Inches	
	MIN	MAX	MIN	MAX
A	1.350	1.750	0.053	0.069
A1	0.100	0.250	0.004	0.010
A2	1.350	1.550	0.053	0.061
b	0.330	0.510	0.013	0.020
c	0.170	0.250	0.006	0.010
D	4.700	5.100	0.185	0.200
E	3.800	4.000	0.150	0.157
E1	5.800	6.200	0.228	0.244
e	1.27 BSC		0.050 BSC	
L	0.400	1.270	0.016	0.050
θ	0°	8°	0°	8°

PACKAGE OUTLINE DIMENSIONS

MSOP-8

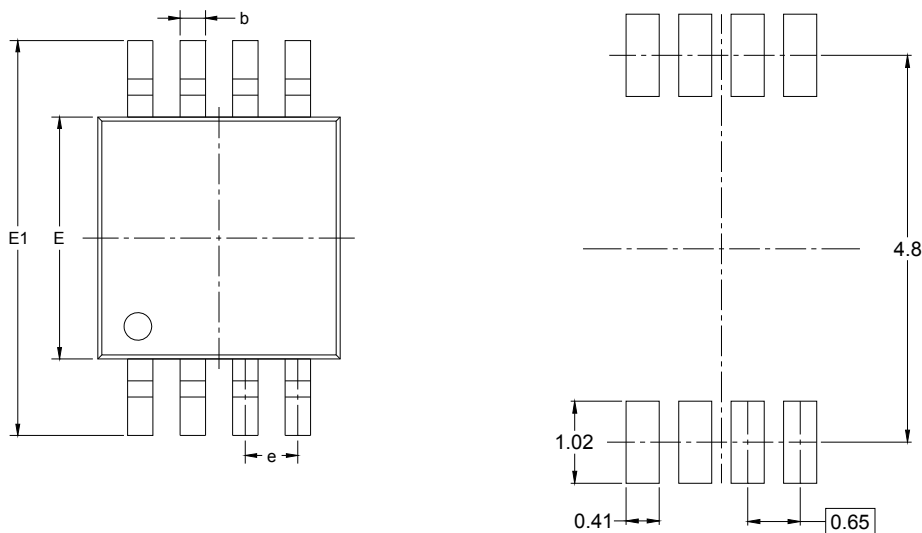

RECOMMENDED LAND PATTERN (Unit: mm)

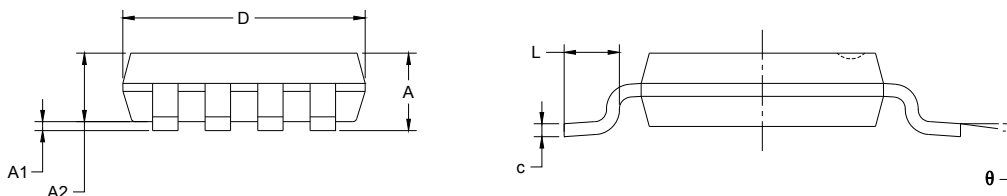

Symbol	Dimensions In Millimeters		Dimensions In Inches	
	MIN	MAX	MIN	MAX
A	0.820	1.100	0.032	0.043
A1	0.020	0.150	0.001	0.006
A2	0.750	0.950	0.030	0.037
b	0.250	0.380	0.010	0.015
c	0.090	0.230	0.004	0.009
D	2.900	3.100	0.114	0.122
E	2.900	3.100	0.114	0.122
E1	4.750	5.050	0.187	0.199
e	0.650 BSC		0.026 BSC	
L	0.400	0.800	0.016	0.031
θ	0°	6°	0°	6°

TAPE AND REEL INFORMATION

REEL DIMENSIONS

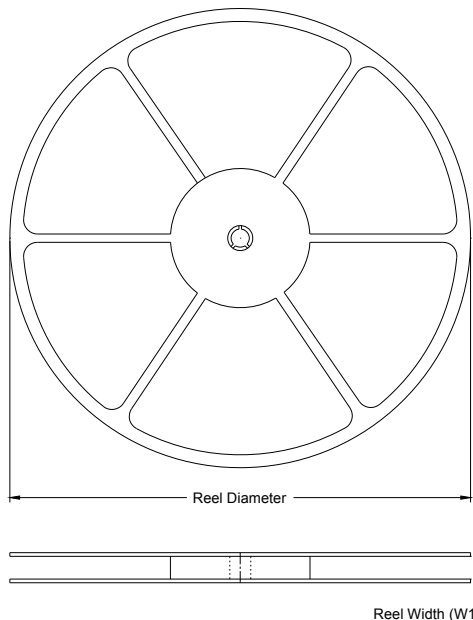

TAPE DIMENSIONS

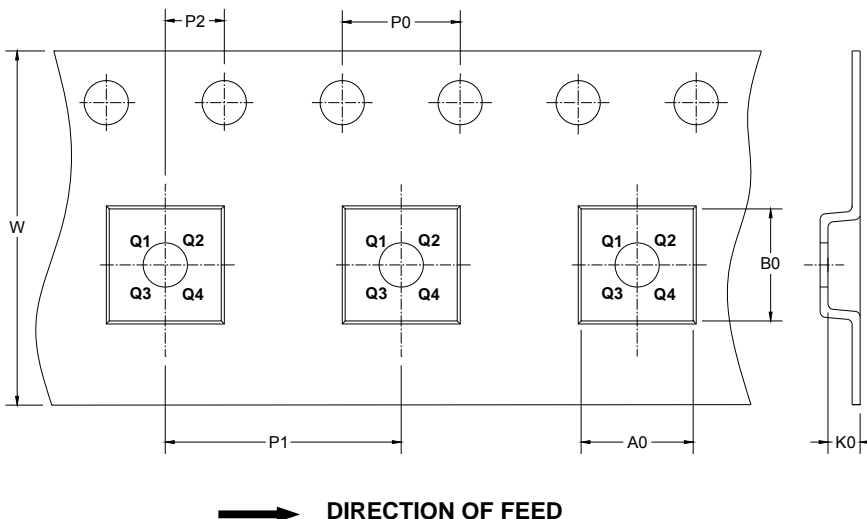

NOTE: The picture is only for reference. Please make the object as the standard.

KEY PARAMETER LIST OF TAPE AND REEL

Package Type	Reel Diameter	Reel Width W1 (mm)	A0 (mm)	B0 (mm)	K0 (mm)	P0 (mm)	P1 (mm)	P2 (mm)	W (mm)	Pin1 Quadrant
SOIC-8	13"	12.4	6.4	5.4	2.1	4.0	8.0	2.0	12.0	Q1
MSOP-8	13"	12.4	5.2	3.3	1.5	4.0	8.0	2.0	12.0	Q1

CARTON BOX DIMENSIONS

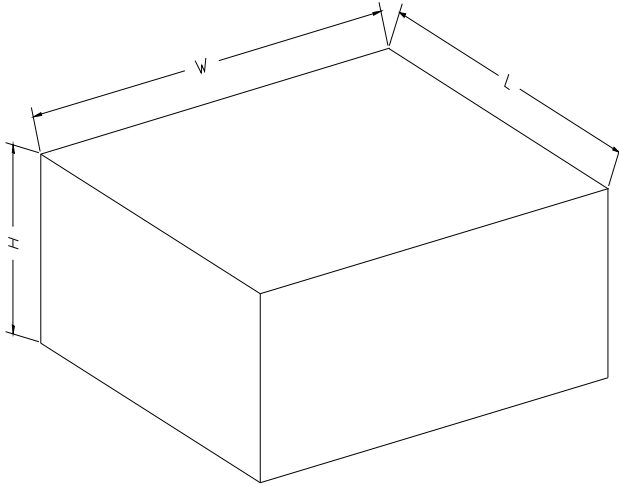

NOTE: The picture is only for reference. Please make the object as the standard.

KEY PARAMETER LIST OF CARTON BOX

Reel Type	Length (mm)	Width (mm)	Height (mm)	Pizza/Carton
13"	386	280	370	5