

### Fast S-IGBT in NPT-Technology

- 75 % lower  $E_{\text{off}}$  compared to previous generation combined with low conduction losses
- Short circuit withstand time 10  $\mu\text{s}$
- Designed for moderate and high frequency applications:
  - SMPS and PFC up to 150 kHz
  - Inverter, Motor controls
- NPT-Technology for 600V applications offers:
  - tighter parameter distribution
  - higher ruggedness, temperature stable behaviour
  - parallel switching capability

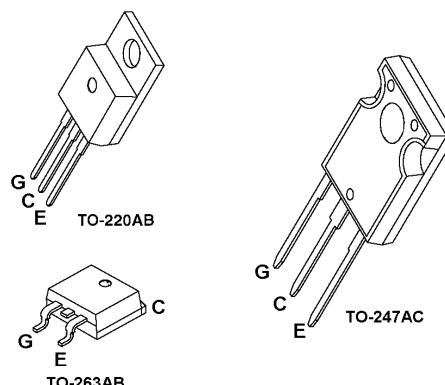

Type	$V_{\text{CE}}$	$I_{\text{C}}$	$V_{\text{CE(sat)}}$	$T_{\text{j}}$	Package	Ordering Code
SGP30N60	600 V	30 A	2.5 V	150 °C	TO-220AB	Q67041-A4713-A2
SGB30N60					TO-263AB	Q67041-A4713-A3
SGW30N60					TO-247AC	Q67040-S4237

### Maximum Ratings

Parameter	Symbol	Value	Unit
Collector-emitter voltage	$V_{\text{CE}}$	600	V
DC collector current	$I_{\text{C}}$		A
$T_{\text{C}} = 25\text{ °C}$		41	
$T_{\text{C}} = 100\text{ °C}$		30	
Pulsed collector current, $t_{\text{p}}$ limited by $T_{\text{jmax}}$	$I_{\text{Cpuls}}$	112	
Gate-emitter voltage	$V_{\text{GE}}$	$\pm 20$	V
Avalanche energy, single pulse $I_{\text{C}} = 30\text{ A}$ , $V_{\text{CC}} = 50\text{ V}$ , $R_{\text{GE}} = 25\ \Omega$ , start at $T_{\text{j}} = 25\text{ °C}$	$E_{\text{AS}}$	165	mJ
Short circuit withstand time <sup>1)</sup> $V_{\text{GE}} = 15\text{ V}$ , $V_{\text{CC}} = 600\text{ V}$ , $T_{\text{j}} \leq 150\text{ °C}$	$t_{\text{sc}}$	10	$\mu\text{s}$
Power dissipation $T_{\text{C}} = 25\text{ °C}$	$P_{\text{tot}}$	250	W
Operating junction and storage temperature	$T_{\text{j}}$ , $T_{\text{stg}}$	-55...+150	°C
Soldering temperature, 1.6mm from case for 10s	-	260	

<sup>1)</sup> allowed number of short circuits: <1000; time between short circuits: >1s

**SIEMENS****SGP30N60, SGB30N60, SGW30N60**

Thermal Resistance					
Parameter	Symbol	Values			Unit
		min.	typ.	max.	
<b>Characteristics</b>					
Thermal resistance, junction - case	$R_{thJC}$	-	-	0.5	K/W
Thermal resistance, junction - ambient	$R_{thJA}$				
TO-220AB		-	-	62	
TO-247AC		-	-	40	
SMD version, device on PCB: <sup>1)</sup>	$R_{thJA}$	-	-	40	
TO-263AB					

**Electrical Characteristics, at  $T_j = 25\text{ °C}$ , unless otherwise specified**

Parameter	Symbol	Values			Unit
		min.	typ.	max.	
<b>Static Characteristics</b>					
Collector-emitter breakdown voltage $V_{GE} = 0\text{ V}$ , $I_C = 500\text{ }\mu\text{A}$	$V_{(BR)CES}$	600	-	-	V
Collector-emitter saturation voltage $V_{GE} = 15\text{ V}$ , $I_C = 30\text{ A}$ , $T_j = 25\text{ °C}$ $V_{GE} = 15\text{ V}$ , $I_C = 30\text{ A}$ , $T_j = 150\text{ °C}$	$V_{CE(sat)}$	1.6 -	2.1 2.5	2.5 3	
Gate-emitter threshold voltage $I_C = 300\text{ }\mu\text{A}$ , $V_{CE} = V_{GE}$	$V_{GE(th)}$	3	4	5	
Zero gate voltage collector current $V_{CE} = 600\text{ V}$ , $V_{GE} = 0\text{ V}$ , $T_j = 25\text{ °C}$ $V_{CE} = 600\text{ V}$ , $V_{GE} = 0\text{ V}$ , $T_j = 150\text{ °C}$	$I_{CES}$	-	-	40 3000	$\mu\text{A}$
Gate-emitter leakage current $V_{GE} = 25\text{ V}$ , $V_{CE} = 0\text{ V}$	$I_{GES}$	-	-	100	

<sup>1)</sup> Device on 50mm\*50mm\*1.5mm epoxy PCB FR4 with 6cm<sup>2</sup> (one layer, 70  $\mu\text{m}$  thick) copper area for collector connection. PCB is vertical without blown air.

### Electrical Characteristics, at $T_j = 25\text{ °C}$ , unless otherwise specified

Parameter	Symbol	Values			Unit
		min.	typ.	max.	
<b>Characteristics</b>					
Transconductance $V_{CE} = 20\text{ V}, I_C = 30\text{ A}$	$g_{fs}$	-	20	-	S
Input capacitance $V_{CE} = 25\text{ V}, V_{GE} = 0\text{ V}, f = 1\text{ MHz}$	$C_{iss}$	-	1600	1920	pF
Output capacitance $V_{CE} = 25\text{ V}, V_{GE} = 0\text{ V}, f = 1\text{ MHz}$	$C_{oss}$	-	150	180	
Reverse transfer capacitance $V_{CE} = 25\text{ V}, V_{GE} = 0\text{ V}, f = 1\text{ MHz}$	$C_{rss}$	-	92	110	

### Characteristics

Gate charge $V_{CC} = 480\text{ V}, V_{GE} = 15\text{ V}, I_C = 30\text{ A}$	$Q_{Gate}$	-	140	182	nC
Internal emitter inductance measured 5mm from case	$L_E$	-	7	-	nH

### Safe Operating Area Characteristics

Short circuit collector current 1) $V_{CE} \leq 600\text{ V}, V_{GE} = 15\text{ V}, t_{sc} \leq 10\text{ }\mu\text{s},$ $T_j \leq 150\text{ °C}$	-	-	-	300	A
Turn off safe operating area $V_{CE} \leq 600\text{ V}, T_j \leq 150\text{ °C}$	-	-	-	112	

1) allowed number of short circuits: <1000; time between short circuits: >1s

**SIEMENS****SGP30N60, SGB30N60, SGW30N60****Switching Characteristics, Inductive Load (Diode: BUP603D), at  $T_j = 25\text{ °C}$** 

Parameter	Symbol	Values			Unit
		min.	typ.	max.	
<b>Characteristics</b>					
Turn-on delay time $V_{CC} = 400\text{ V}$ , $V_{GE} = 15\text{ V}$ , $I_C = 30\text{ A}$ , $R_{Gon} = 11\text{ }\Omega$	$t_{d(on)}$	-	31	37	ns
Rise time $V_{CC} = 400\text{ V}$ , $V_{GE} = 15\text{ V}$ , $I_C = 30\text{ A}$ , $R_{Gon} = 11\text{ }\Omega$	$t_r$	-	48	58	
Turn-off delay time $V_{CC} = 400\text{ V}$ , $V_{GE} = 0\text{ V}$ , $I_C = 30\text{ A}$ , $R_{Goff} = 11\text{ }\Omega$	$t_{d(off)}$	-	291	350	
Fall time $V_{CC} = 400\text{ V}$ , $V_{GE} = 0\text{ V}$ , $I_C = 30\text{ A}$ , $R_{Goff} = 11\text{ }\Omega$	$t_f$	-	58	70	
Turn-on energy <sup>1)</sup> $V_{CC} = 400\text{ V}$ , $V_{GE} = 15\text{ V}$ , $I_C = 30\text{ A}$ , $R_{Gon} = 11\text{ }\Omega$	$E_{on}$	-	1.34	1.54	mJ
Turn-off energy $V_{CC} = 400\text{ V}$ , $V_{GE} = 0\text{ V}$ , $I_C = 30\text{ A}$ , $R_{Goff} = 11\text{ }\Omega$	$E_{off}$	-	0.65	0.85	
Total switching energy <sup>1)</sup> $V_{CC} = 400\text{ V}$ , $V_{GE} = 0/+15\text{ V}$ , $I_C = 30\text{ A}$ , $R_G = 11\text{ }\Omega$	$E_{ts}$	-	1.99	2.39	

1)  $E_{on}$  and  $E_{ts}$  include BUP603D diode commutation losses.

**SIEMENS****SGP30N60, SGB30N60, SGW30N60****Switching Characteristics, Inductive Load (Diode: BUP603D), at  $T_j = 150\text{ °C}$** 

Parameter	Symbol	Values			Unit
		min.	typ.	max.	
<b>Characteristics</b>					
Turn-on delay time $V_{CC} = 400\text{ V}$ , $V_{GE} = 15\text{ V}$ , $I_C = 30\text{ A}$ , $R_{Gon} = 11\ \Omega$	$t_{d(on)}$	-	30	36	ns
Rise time $V_{CC} = 400\text{ V}$ , $V_{GE} = 15\text{ V}$ , $I_C = 30\text{ A}$ , $R_{Gon} = 11\ \Omega$	$t_r$	-	46	55	
Turn-off delay time $V_{CC} = 400\text{ V}$ , $V_{GE} = 0\text{ V}$ , $I_C = 30\text{ A}$ , $R_{Goff} = 11\ \Omega$	$t_{d(off)}$	-	324	389	
Fall time $V_{CC} = 400\text{ V}$ , $V_{GE} = 0\text{ V}$ , $I_C = 30\text{ A}$ , $R_{Goff} = 11\ \Omega$	$t_f$	-	67	80	
Turn-on energy <sup>1)</sup> $V_{CC} = 400\text{ V}$ , $V_{GE} = 15\text{ V}$ , $I_C = 30\text{ A}$ , $R_{Gon} = 11\ \Omega$	$E_{on}$	-	1.81	2.08	mJ
Turn-off energy $V_{CC} = 400\text{ V}$ , $V_{GE} = 0\text{ V}$ , $I_C = 30\text{ A}$ , $R_{Goff} = 11\ \Omega$	$E_{off}$	-	0.92	1.2	
Total switching energy <sup>1)</sup> $V_{CC} = 400\text{ V}$ , $V_{GE} = 0/+15\text{ V}$ , $I_C = 30\text{ A}$ , $R_G = 11\ \Omega$	$E_{ts}$	-	2.73	3.28	

1)  $E_{on}$  and  $E_{ts}$  include BUP603D diode commutation losses.

### Typ. collector current

$$I_C = f(f)$$

parameter:  $D = 0.5, T_j \leq 150\text{ }^\circ\text{C}$

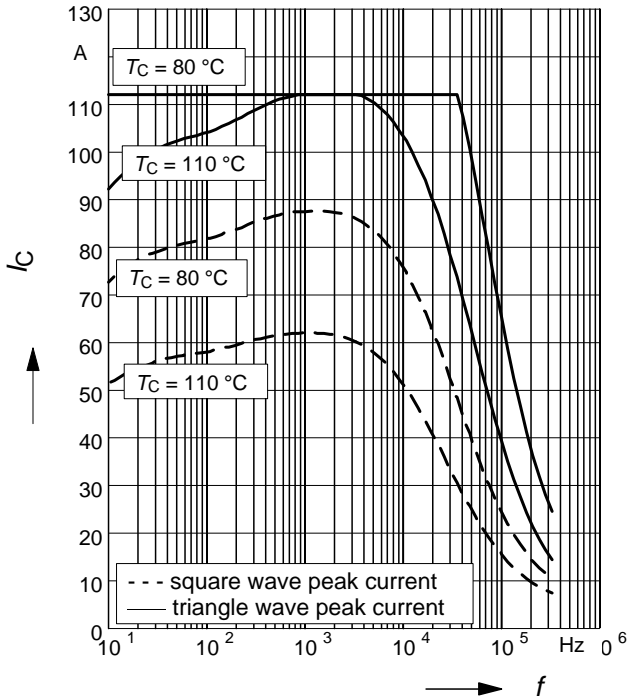

### Safe operating area

$$I_C = f(V_{CE})$$

parameter:  $D = 0, T_C = 25\text{ }^\circ\text{C}, T_j \leq 150\text{ }^\circ\text{C}$

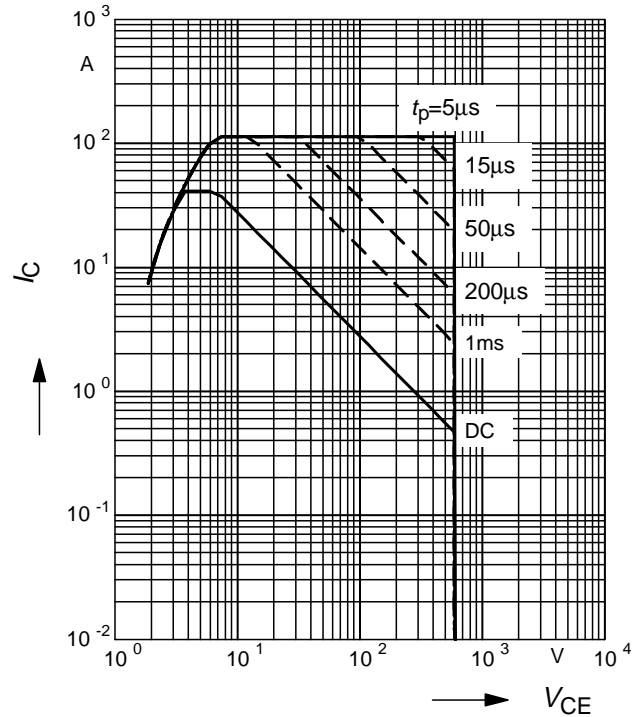

### Power dissipation

$$P_{tot} = f(T_C)$$

parameter:  $T_j \leq 150\text{ }^\circ\text{C}$

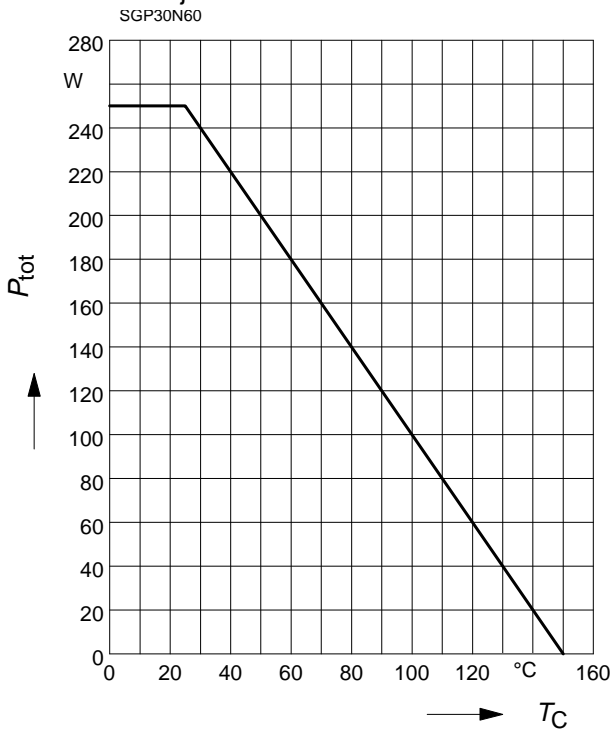

### Collector current

$$I_C = f(T_C)$$

parameter:  $V_{GE} \geq 15\text{ V}, T_j \leq 150\text{ }^\circ\text{C}$

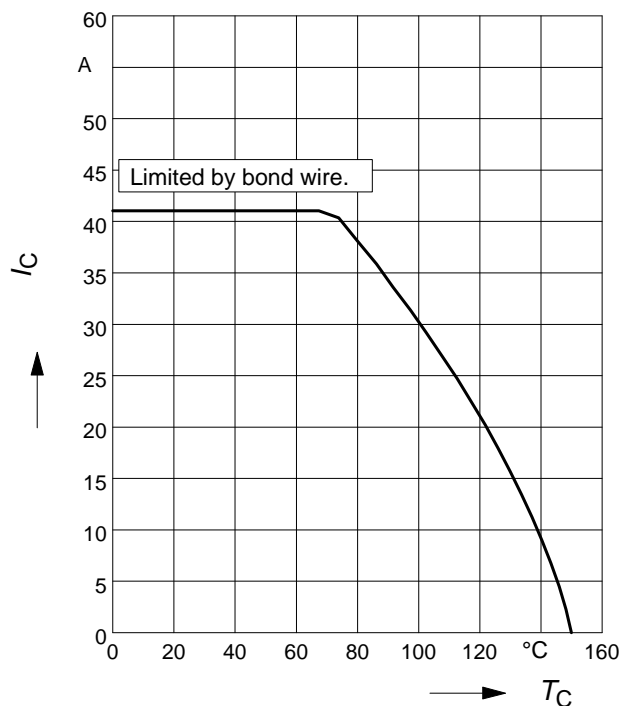

### Typ. output characteristics

$$I_C = f(V_{CE})$$

parameter:  $t_p = 80 \mu s$ ,  $T_j = 25 \text{ }^\circ\text{C}$

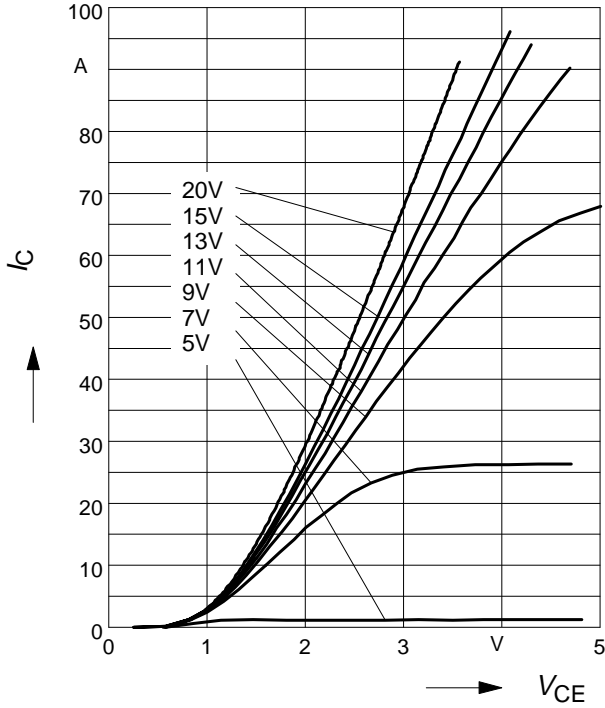

### Typ. output characteristics

$$I_C = f(V_{CE})$$

parameter:  $t_p = 80 \mu s$ ,  $T_j = 150 \text{ }^\circ\text{C}$

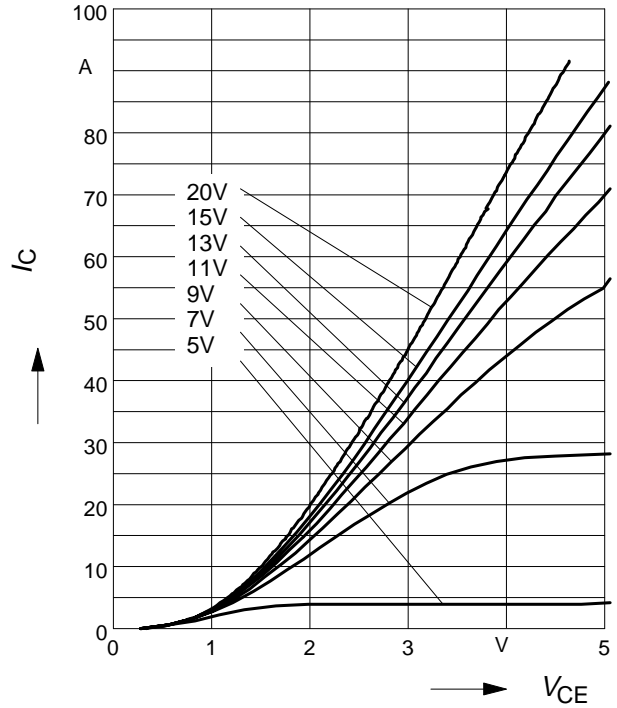

### Typ. transfer characteristics

$$I_C = f(V_{GE})$$

parameter:  $t_p = 80 \mu s$ ,  $V_{CE} = 10 \text{ V}$

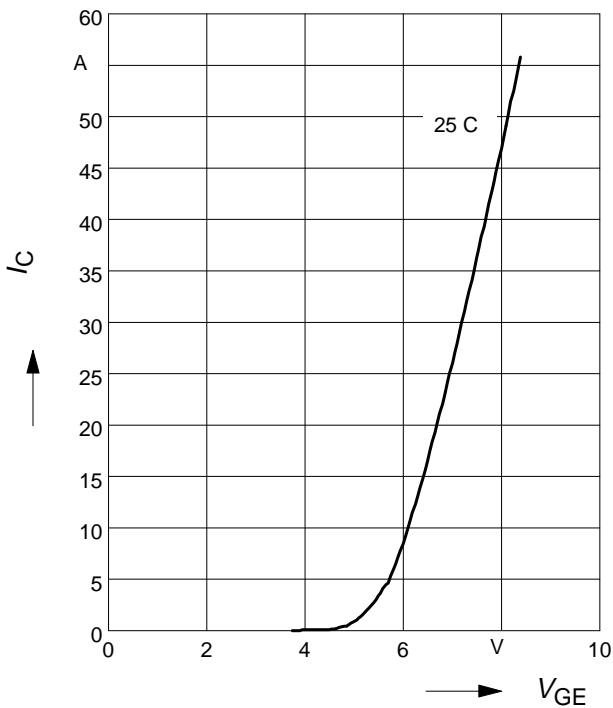

### Gate-emitter threshold voltage

$$V_{GE(th)} = f(T_j)$$

parameter:  $I_C = 0.3 \text{ mA}$

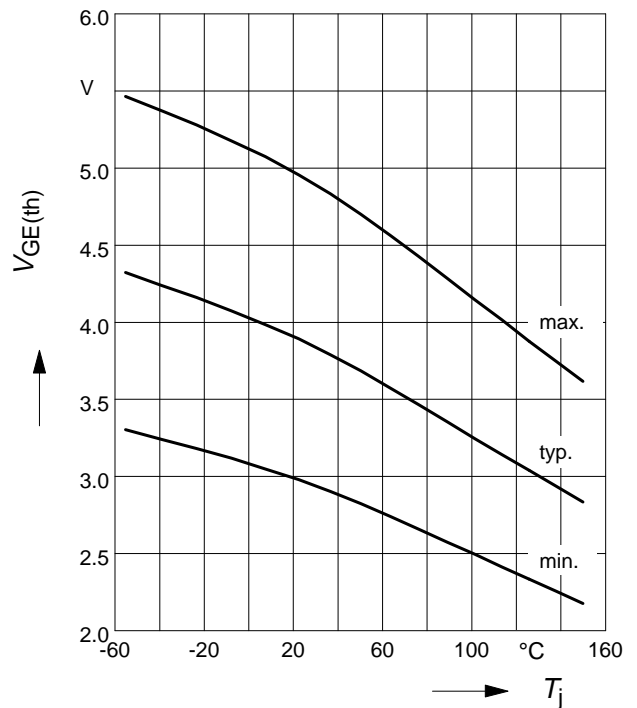

# SIEMENS

## SGP30N60, SGB30N60, SGW30N60

### Typ. switching time

$t = f(I_C)$ , inductive load,  $T_j = 150^\circ\text{C}$

par.:  $V_{CE} = 400\text{ V}$ ,  $V_{GE} = 0/+15\text{ V}$ ,  $R_G = 11\ \Omega$

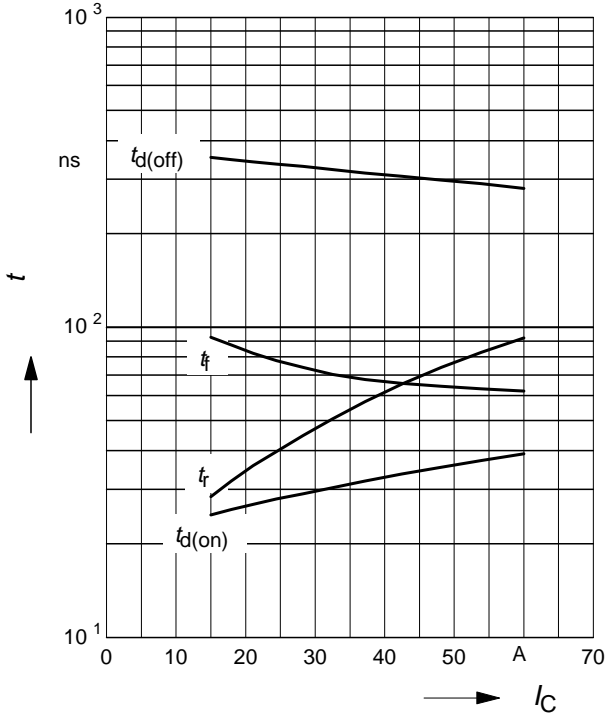

### Typ. switching time

$t = f(R_G)$ , inductive load,  $T_j = 150^\circ\text{C}$

par.:  $V_{CE} = 400\text{ V}$ ,  $V_{GE} = 0/+15\text{ V}$ ,  $I_C = 30\text{ A}$

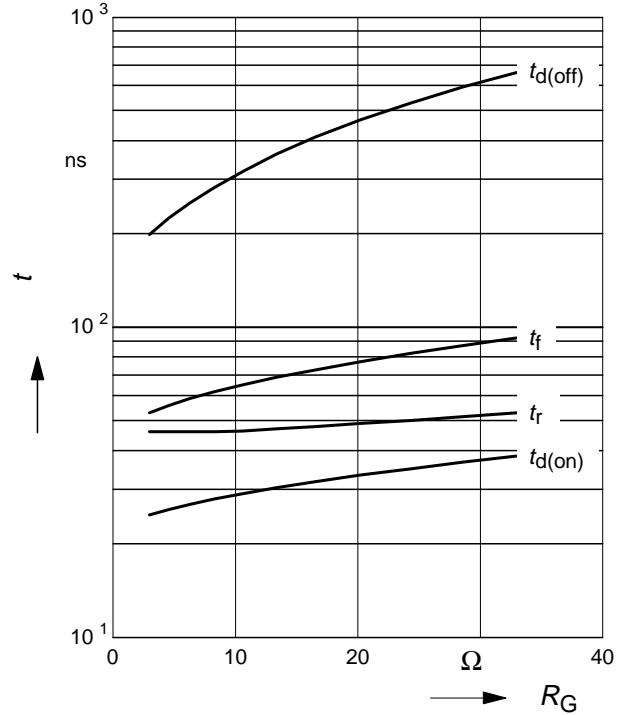

### Typ. switching time

$t = f(T_j)$ , inductive load,  $V_{CE} = 400\text{ V}$

$V_{GE} = 0/+15\text{ V}$ ,  $I_C = 30\text{ A}$ ,  $R_G = 11\ \Omega$

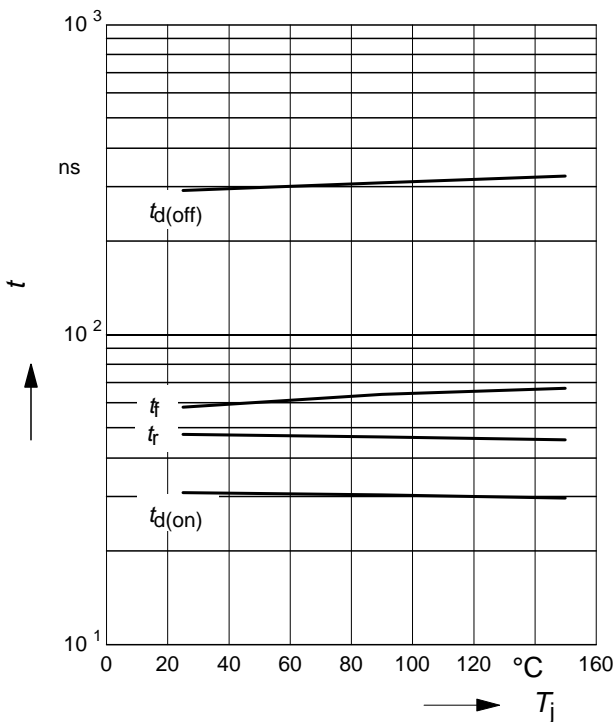

### Typ. collector-emitter saturation voltage

$V_{CE(sat)} = f(T_j)$

parameter:  $V_{GE} = 15\text{ V}$

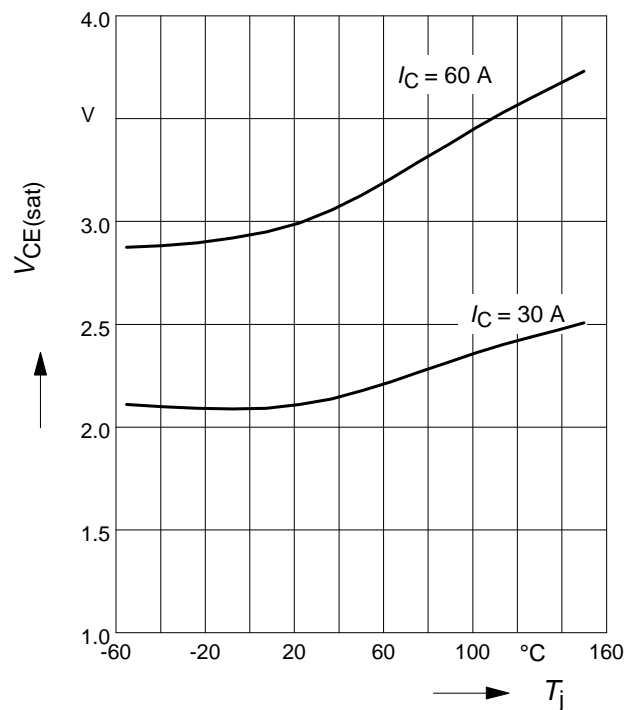



### Typ. switching losses

$E = f(I_C)$ , inductive load,  $T_j = 150^\circ\text{C}$

par.:  $V_{CE} = 400\text{ V}$ ,  $V_{GE} = 0/+15\text{ V}$ ,  $R_G = 11\ \Omega$

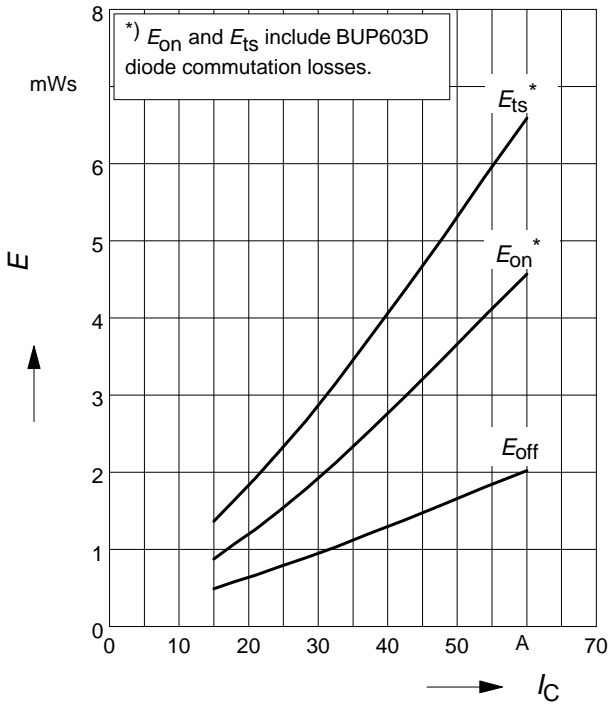

### Typ. switching losses

$E = f(R_G)$ , inductive load,  $T_j = 150^\circ\text{C}$

par.:  $V_{CE} = 400\text{ V}$ ,  $V_{GE} = 0/+15\text{ V}$ ,  $I_C = 30\text{ A}$

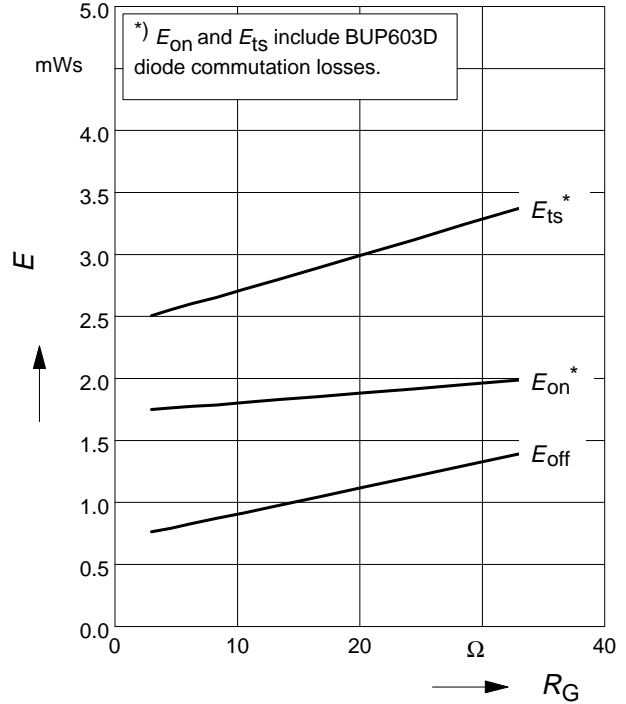

### Typ. switching losses

$E = f(T_j)$ , inductive load,  $V_{CE} = 400\text{ V}$ ,

$V_{GE} = 0/+15\text{ V}$ ,  $I_C = 30\text{ A}$ ,  $R_G = 11\ \Omega$

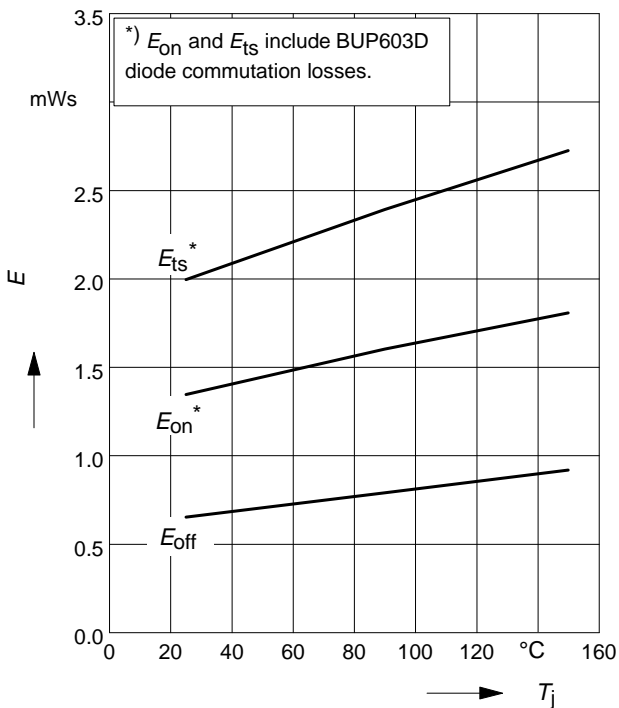

### Transient thermal impedance

$Z_{thJC} = f(t_p)$

parameter:  $D = t_p / T$

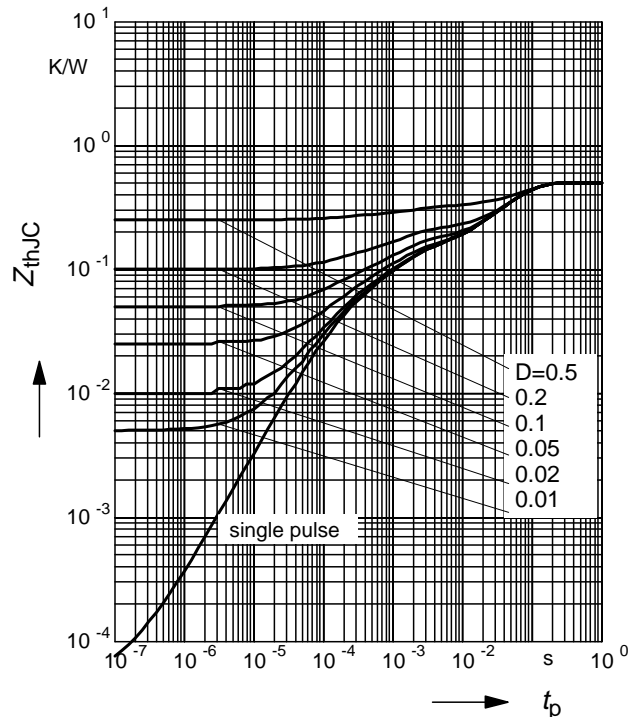

### Typ. gate charge

$$V_{GE} = f(Q_{Gate})$$

parameter:  $I_C = 30\text{ A}$

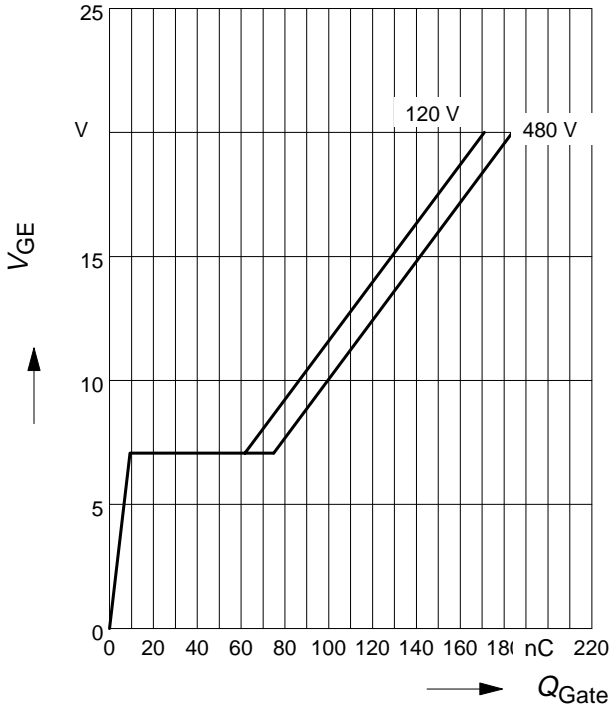

### Typ. capacitances

$$C = f(V_{CE})$$

parameter:  $V_{GE} = 0\text{ V}$ ,  $f = 1\text{ MHz}$

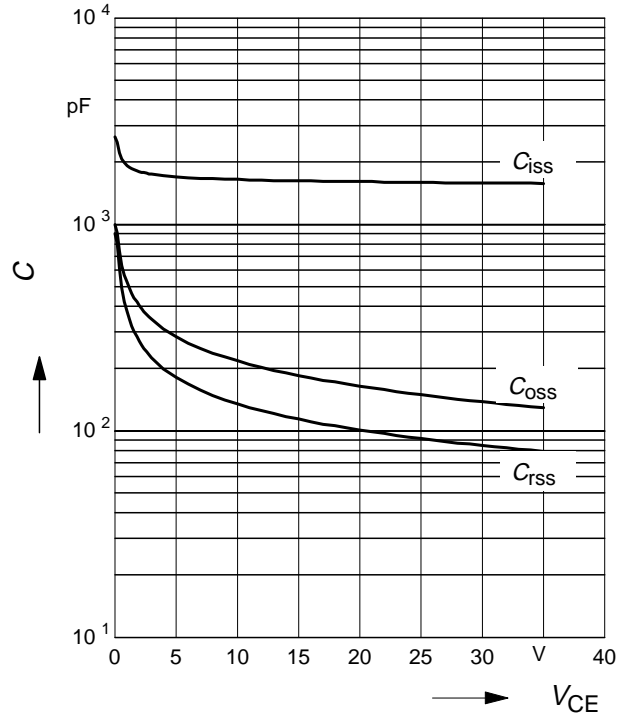

### Short circuit withstand time

$$t_{sc} = f(V_{GE})$$

par.:  $V_{CE} = 600\text{ V}$ , start at  $T_j = 25\text{ °C}$

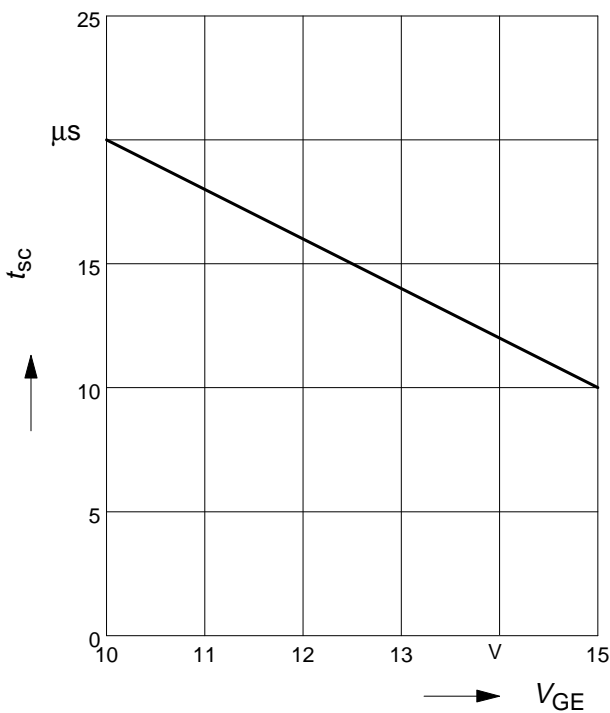

### Typ. short circuit current

$$I_{Csc} = f(V_{GE})$$

par.:  $V_{CE} \leq 600\text{ V}$ ,  $T_C = 25\text{ °C}$ ,  $T_j \leq 150\text{ °C}$

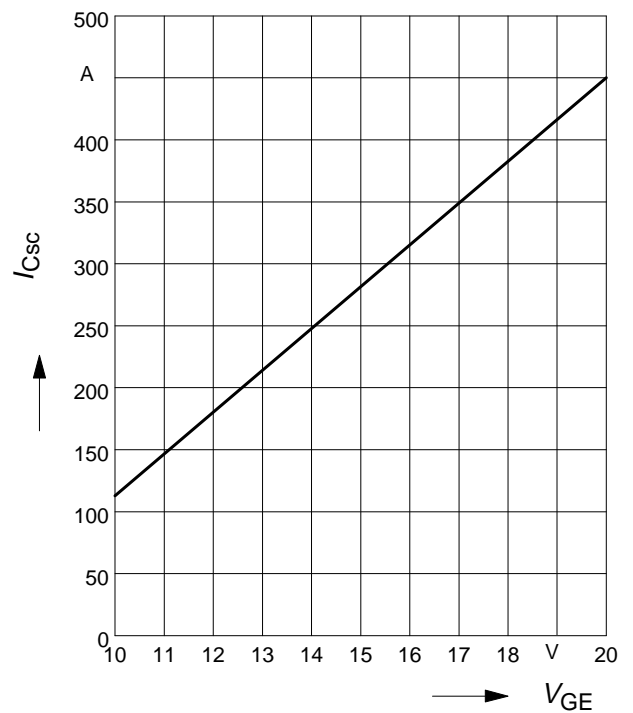

TO-220AB

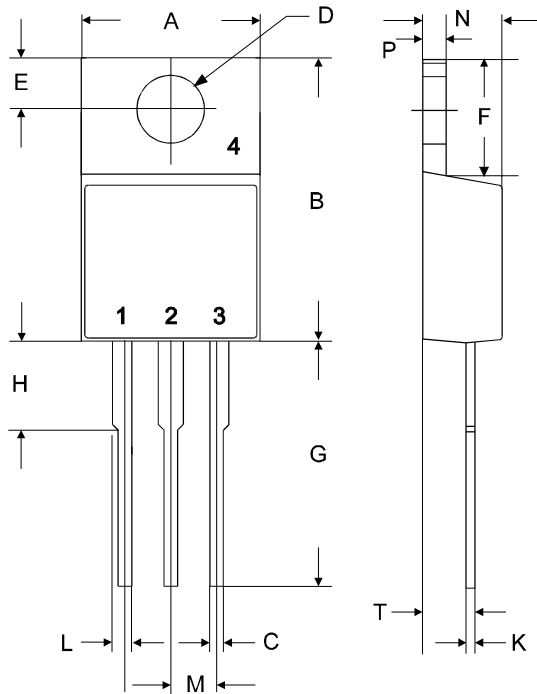

symbol	dimensions [mm]	
	min	max
A	9.70	10.30
B	14.88	15.95
C	0.65	0.86
D	3.55	3.89
E	2.60	3.00
F	6.00	6.80
G	13.00	14.00
H	4.35	4.75
K	0.38	0.65
L	0.95	1.32
M	2.54 typ.	
N	4.30	4.50
P	1.17	1.40
T	2.30	2.72

TO-263AB

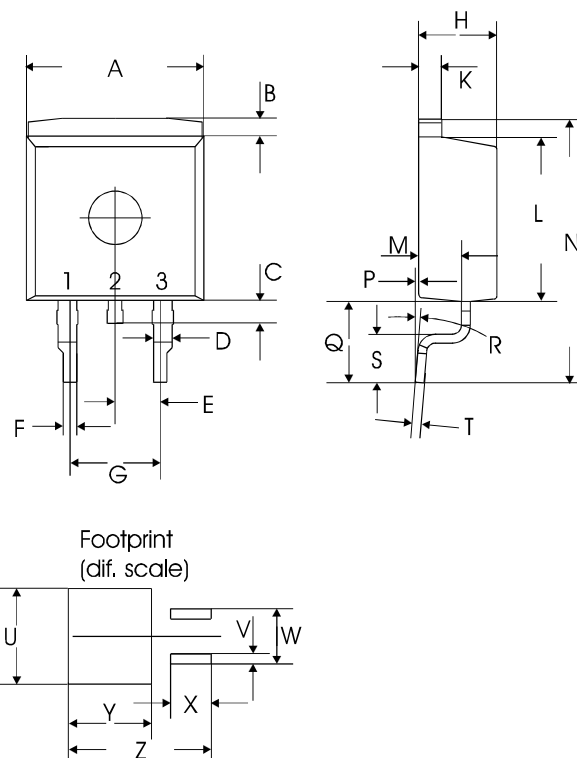

symbol	dimensions [mm]	
	min	max
A	9.80	10.20
B	0.70	1.30
C	1.00	1.60
D	1.03	1.07
E	2.54 typ.	
F	0.65	0.85
G	5.08 typ.	
H	4.30	4.50
K	1.17	1.37
L	9.05	9.45
M	2.30	2.50
N	15 typ.	
P	0.00	0.20
Q	4.20	5.20
R	8° max	
S	2.40	3.00
T	0.40	0.60
U	10.80	
V	1.15	
W	6.23	
X	4.60	
Y	9.40	
Z	16.15	

**Edition 02 / 1999**

**Published by Siemens AG,  
Bereich Halbleiter Vertrieb,  
Werbung, Balanstraße 73,  
81541 München**

© Siemens AG 1997

All Rights Reserved.

**Attention please!**

As far as patents or other rights of third parties are concerned, liability is only assumed for components, not for applications, processes and circuits implemented within components or assemblies.

The information describes a type of component and shall not be considered as warranted characteristics.

Terms of delivery and rights to change design reserved.

For questions on technology, delivery and prices please contact the Semiconductor Group Offices in Germany or the Siemens Companies and Representatives worldwide (see address list).

Due to technical requirements components may contain dangerous substances. For information on the types in question please contact your nearest Siemens Office, Semiconductor Group.

Siemens AG is an approved CECC manufacturer.

**Packing**

Please use the recycling operators known to you. We can also help you - get in touch with your nearest sales office. By agreement we will take packing material back, if it is sorted. You must bear the costs of transport. For packing material that is returned to us unsorted or which we are not obliged to accept, we shall have to invoice you for any costs incurred.

**Components used in life-support devices or systems must be expressly authorized for such purpose!**

Critical components<sup>1</sup> of the Semiconductor Group of Siemens AG, may only be used in life-support devices or systems<sup>2</sup> with the express written approval of the Semiconductor Group of Siemens AG.

1) A critical component is a component used in a life-support device or system whose failure can reasonably be expected to cause the failure of that life-support device or system, or to affect its safety or effectiveness of that device or system.

2) Life support devices or systems are intended (a) to be implanted in the human body, or (b) to support and/or maintain and sustain and/or protect human life. If they fail, it is reasonable to assume that the health of the user or other persons may be endangered.