

## 40A, 1200V FIELD STOP IGBT

### DESCRIPTION

SGT40T120SDB4P7 adopts Silan Field Stop IV IGBT technology, features low conduction loss and switching loss, positive temperature coefficient for easy parallel operation. This device is applicable to frequency converters, UPS, and SMPS fields.

### FEATURES

- ◆ 40A, 1200V,  $V_{CE(sat)(typ.)}=1.8V@I_C=40A$
- ◆ Ultra low conduction loss
- ◆ Fast switching
- ◆ High breakdown voltage
- ◆  $T_{Jmax}=175^{\circ}C$

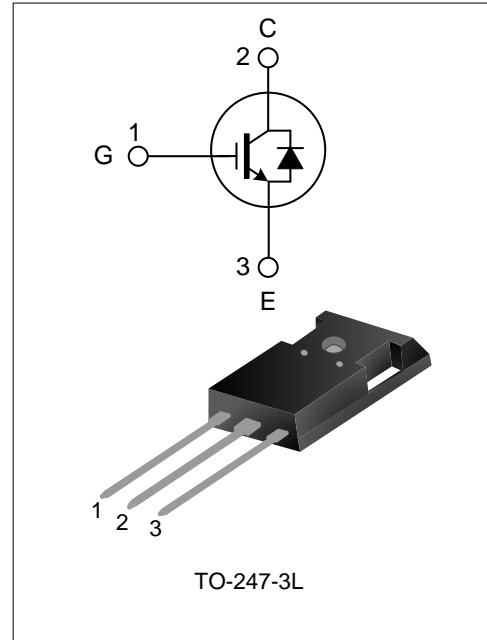

### NOMENCLATURE

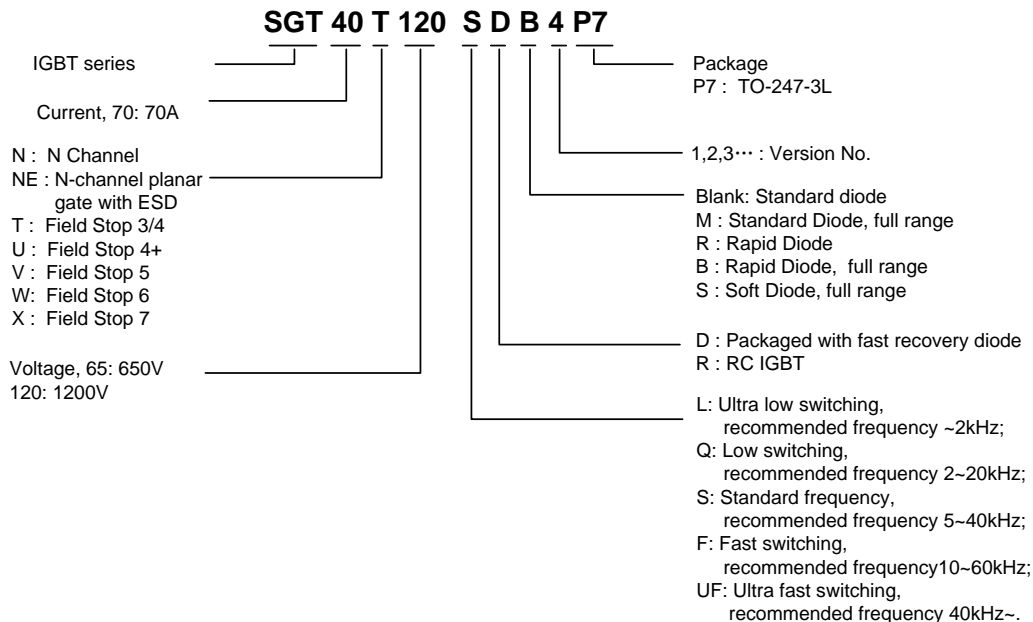

### ORDERING INFORMATION

Part No.	Package	Marking	Hazardous Substance Control	Packing Type
SGT40T120SDB4P7	TO-247-3L	40T120SDB4	Pb free	Tube

**ABSOLUTE MAXIMUM RATINGS (UNLESS OTHERWISE NOTED, T<sub>C</sub>=25°C)**

Characteristics	Symbol	Ratings	Unit
Collector to Emitter Voltage	V <sub>CE</sub>	1200	V
Gate to Emitter Voltage	V <sub>GE</sub>	±20	V
Collector Current	I <sub>C</sub>	T <sub>C</sub> =25°C	80
		T <sub>C</sub> =100°C	40
Pulsed Collector Current	I <sub>CM</sub>	160	A
Diode Current	I <sub>F</sub>	T <sub>C</sub> =25°C	80
		T <sub>C</sub> =100°C	40
Diode Pulse Current	I <sub>FM</sub>	160	A
Short Circuit Withstand Time	T <sub>sc</sub>	10	μs
Power Dissipation (T <sub>C</sub> =25°C) - Derate above 25°C	P <sub>D</sub>	428	W
		2.85	W/°C
Operating Junction Temperature	T <sub>J</sub>	-55~+175	°C
Storage Temperature Range	T <sub>stg</sub>	-55~+150	°C

**THERMAL CHARACTERISTICS**

Characteristics	Symbol	Ratings	Unit
Thermal Resistance, Junction-to-Case (IGBT)	R <sub>θJC</sub>	0.32	°C/W
Thermal Resistance, Junction-to-Case (FRD)	R <sub>θJC</sub>	0.52	°C/W
Thermal Resistance, Junction-to-Ambient	R <sub>θJA</sub>	40	°C/W

**ELECTRICAL CHARACTERISTICS OF IGBT (UNLESS OTHERWISE NOTED,  $T_c=25^\circ\text{C}$ )**

Characteristics	Symbol	Test conditions	Min.	Typ.	Max.	Unit
Collector to Emitter Breakdown Voltage	$BV_{CE}$	$V_{GE}=0V, I_C=1mA$	1200	--	--	V
C-E Leakage Current	$I_{CES}$	$V_{CE}=1200V, V_{GE}=0V$	--	--	500	$\mu A$
G-E Leakage Current	$I_{GES}$	$V_{GE}=20V, V_{CE}=0V$	--	--	$\pm 400$	nA
G-E Threshold Voltage	$V_{GE(th)}$	$I_C=4.0mA, V_{CE}=V_{GE}$	4	5.5	7	V
Collector to Emitter Saturation Voltage	$V_{CE(sat)}$	$I_C=40A, V_{GE}=15V, T_J=25^\circ\text{C}$	--	1.8	2.4	V
		$I_C=40A, V_{GE}=15V, T_J=150^\circ\text{C}$	--	2.1	--	V
Input Capacitance	$C_{ies}$	$V_{CE}=30V, V_{GE}=0V, f=1MHz$	--	4100	--	pF
Output Capacitance	$C_{oes}$		--	190	--	
Reverse Transfer Capacitance	$C_{res}$		--	80	--	
Turn-On Delay Time	$T_{d(on)}$	$V_{CE}=600V, I_C=40A, R_g=10\Omega$ $V_{GE}=15V, \text{Inductive load}$ $T_J=25^\circ\text{C}$	--	45	--	ns
Rise Time	$T_r$		--	120	--	
Turn-Off Delay Time	$T_{d(off)}$		--	270	--	
Fall Time	$T_f$		--	200	--	
Turn-On Switching Loss	$E_{on}$			--	4.5	--
Turn-Off Switching Loss	$E_{off}$	--		1.8	--	
Total Switching Loss	$E_{st}$	--		6.3	--	
Total Gate Charge	$Q_g$	$V_{CE}=600V, I_C=40A,$ $V_{GE}=15V$	--	270	--	nC
Gate to Emitter Charge	$Q_{ge}$		--	45	--	
Gate to Collector Charge	$Q_{gc}$		--	150	--	

**ELECTRICAL CHARACTERISTICS OF FRD (UNLESS OTHERWISE NOTED,  $T_c=25^\circ\text{C}$ )**

Characteristics	Symbol	Test conditions	Min.	Typ.	Max.	Unit
Diode Forward Voltage	$V_{fm}$	$I_F=40A, T_J=25^\circ\text{C}$	--	1.9	2.6	V
		$I_F=40A, T_J=150^\circ\text{C}$	--	1.7	--	
Diode Reverse Recovery Time	$T_{rr}$	$V_{DD}=200V, I_{ES}=40A,$ $dI_{ES}/dt=100A/\mu s, T_J=25^\circ\text{C}$	--	119	--	ns
Diode Reverse Recovery Charge	$Q_{rr}$		--	0.23	--	$\mu C$
Diode Peak Reverse Recovery Current	$I_{rm}$		--	3.86	--	A
Diode Reverse Recovery Current Tb slope	$Di_{rr}/Dt$		--	103	--	$A/\mu s$

**TYPICAL CHARACTERISTICS**

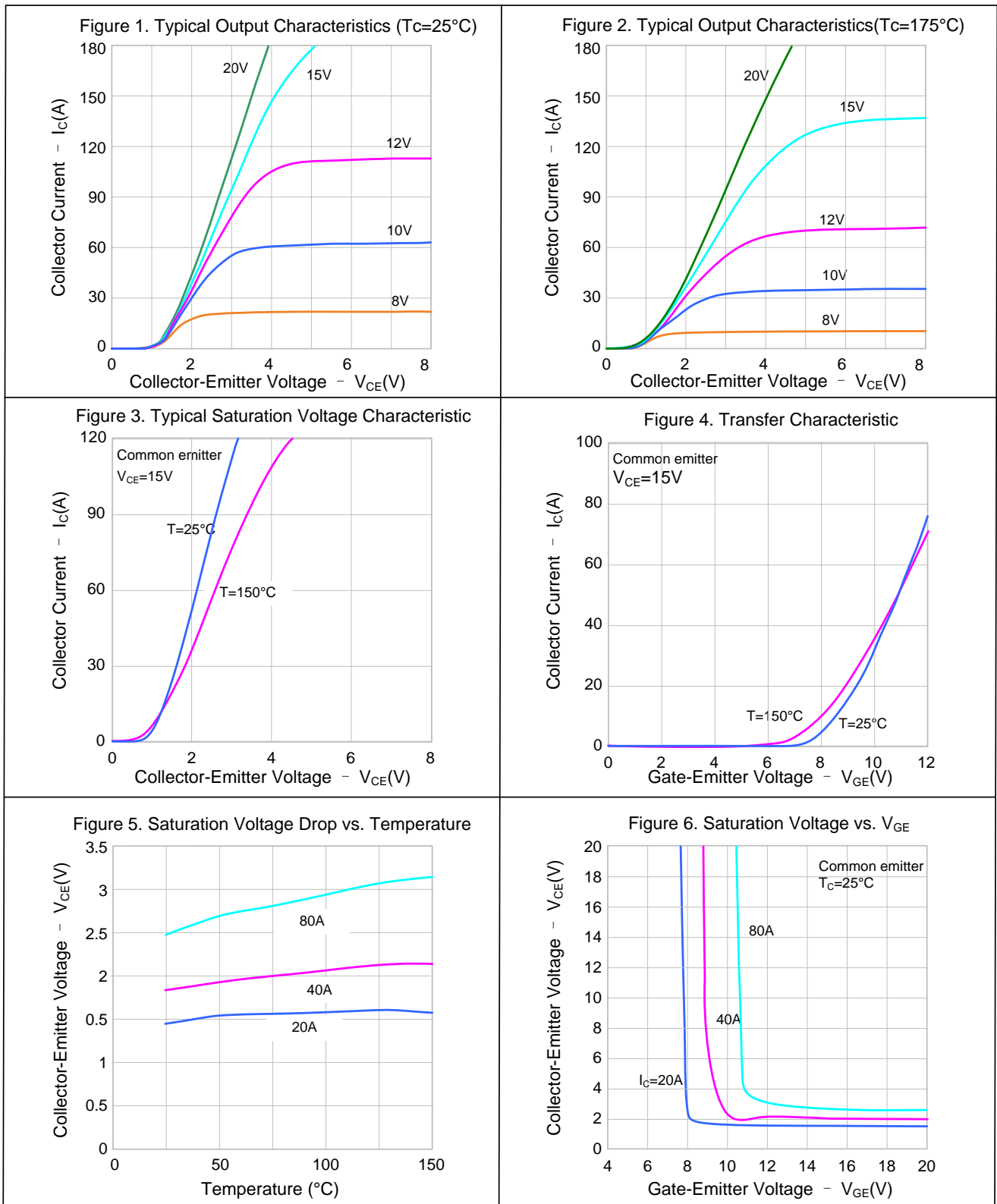

**TYPICAL CHARACTERISTICS (CONTINUED)**

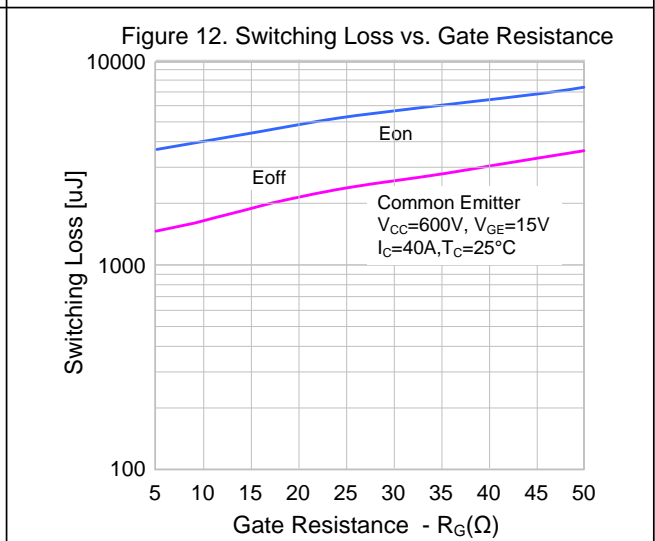
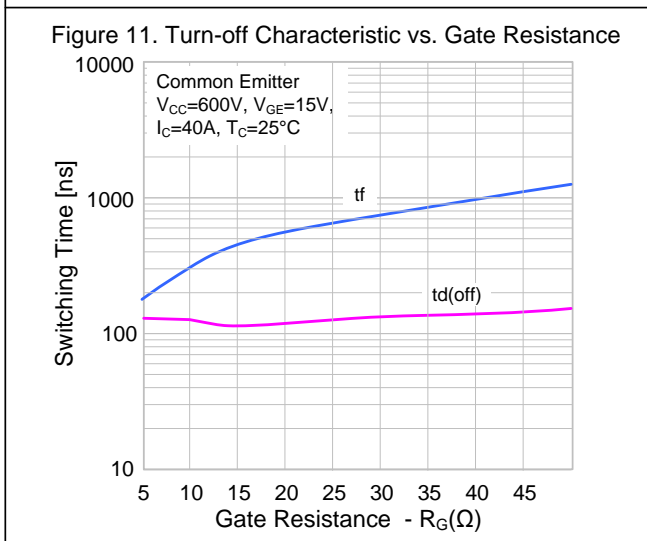
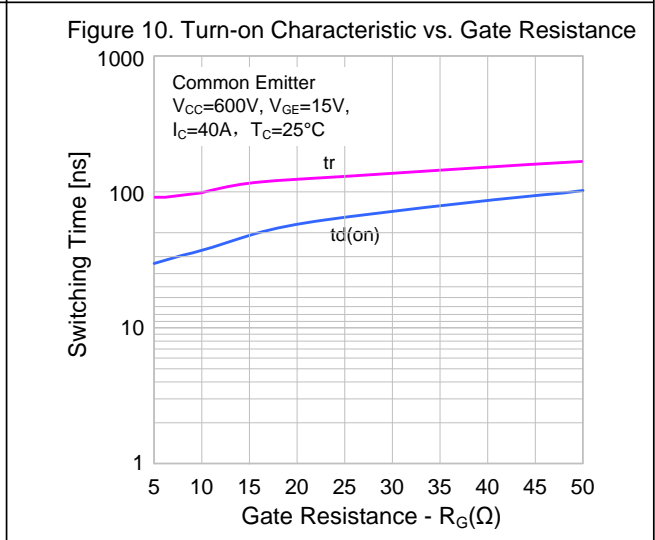
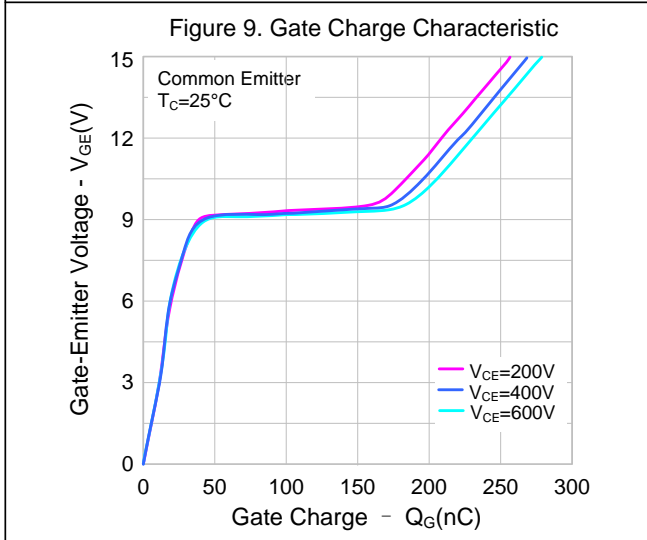
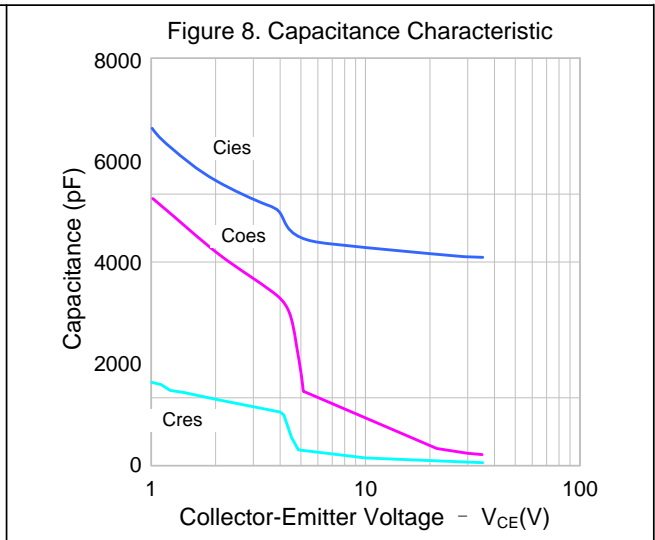
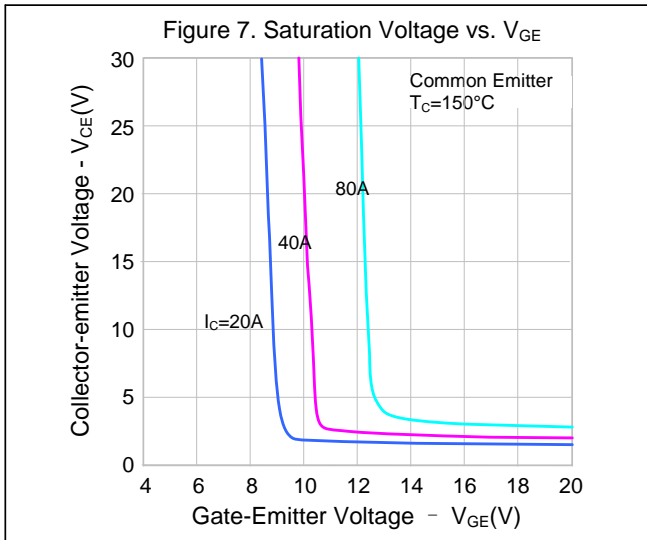

**TYPICAL CHARACTERISTICS (CONTINUED)**

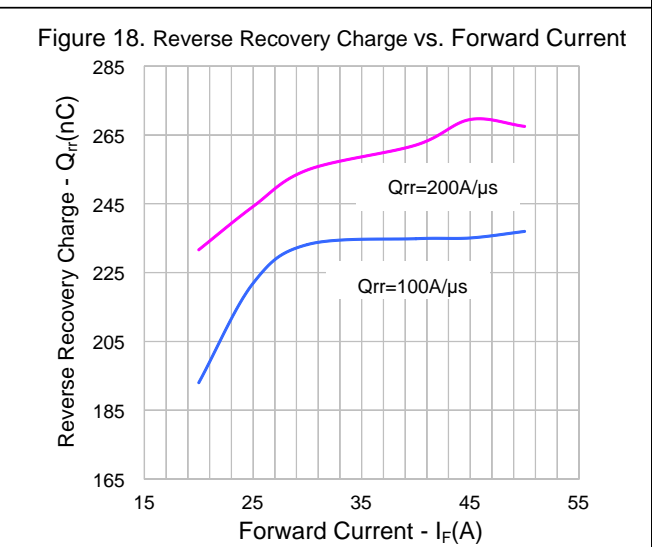
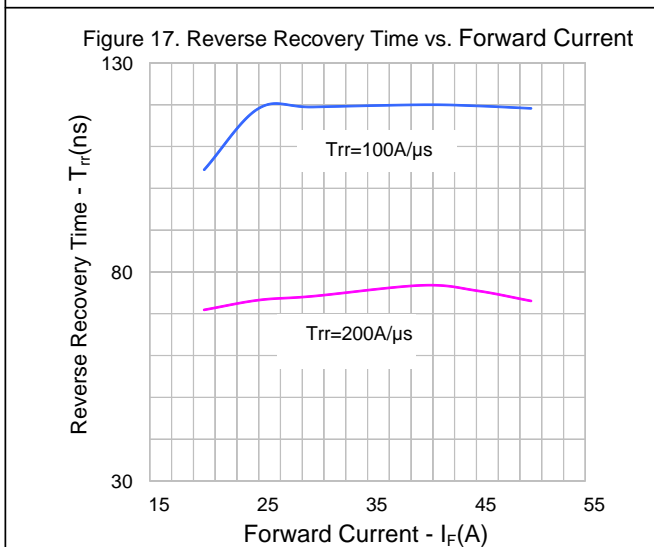
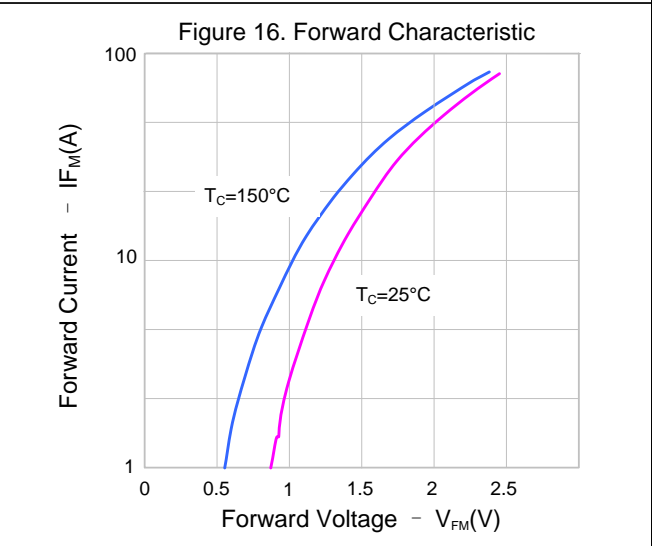
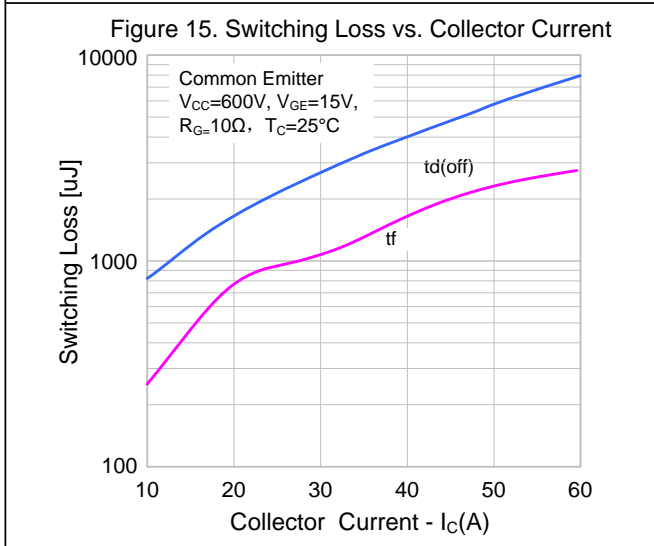
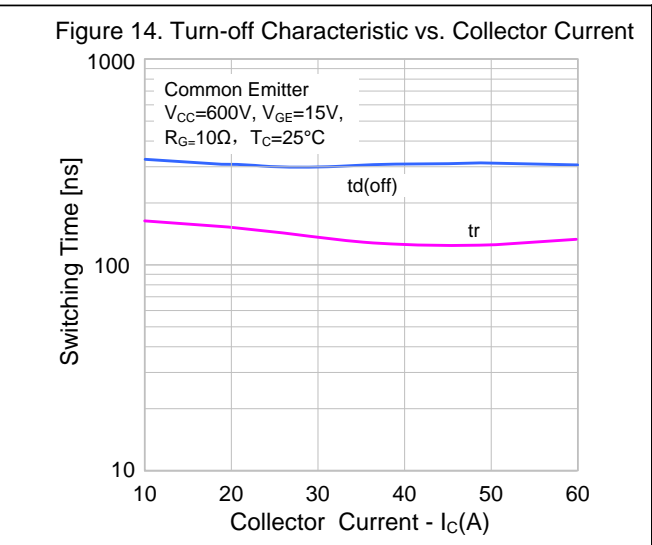
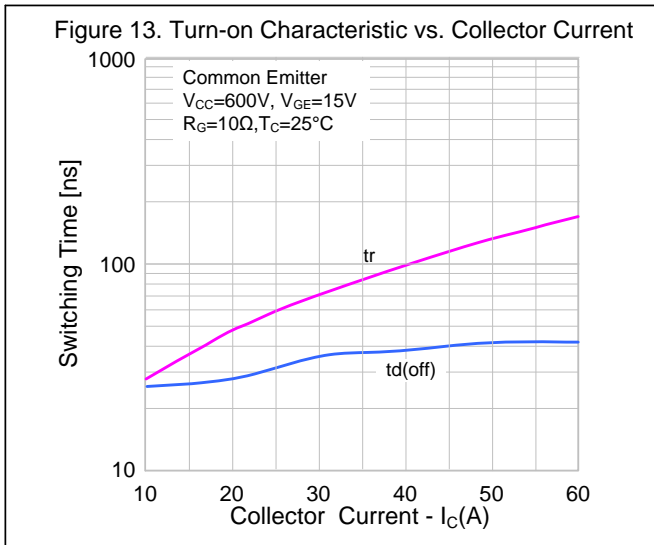

**TYPICAL CHARACTERISTICS (CONTINUED)**

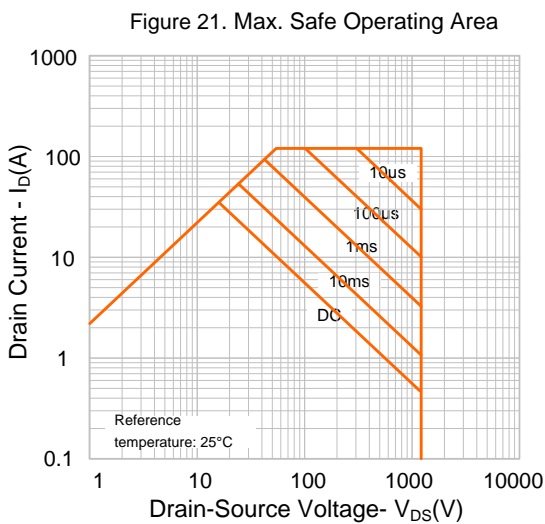
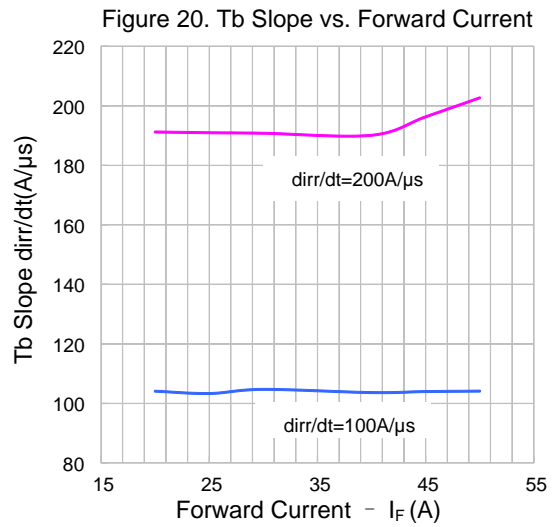
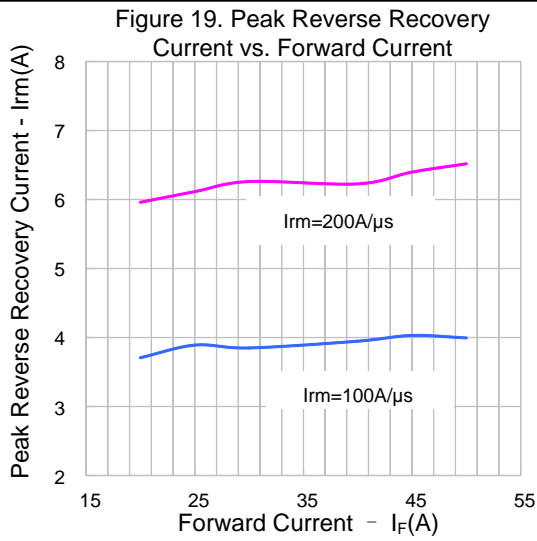

**PACKAGE OUTLINE**

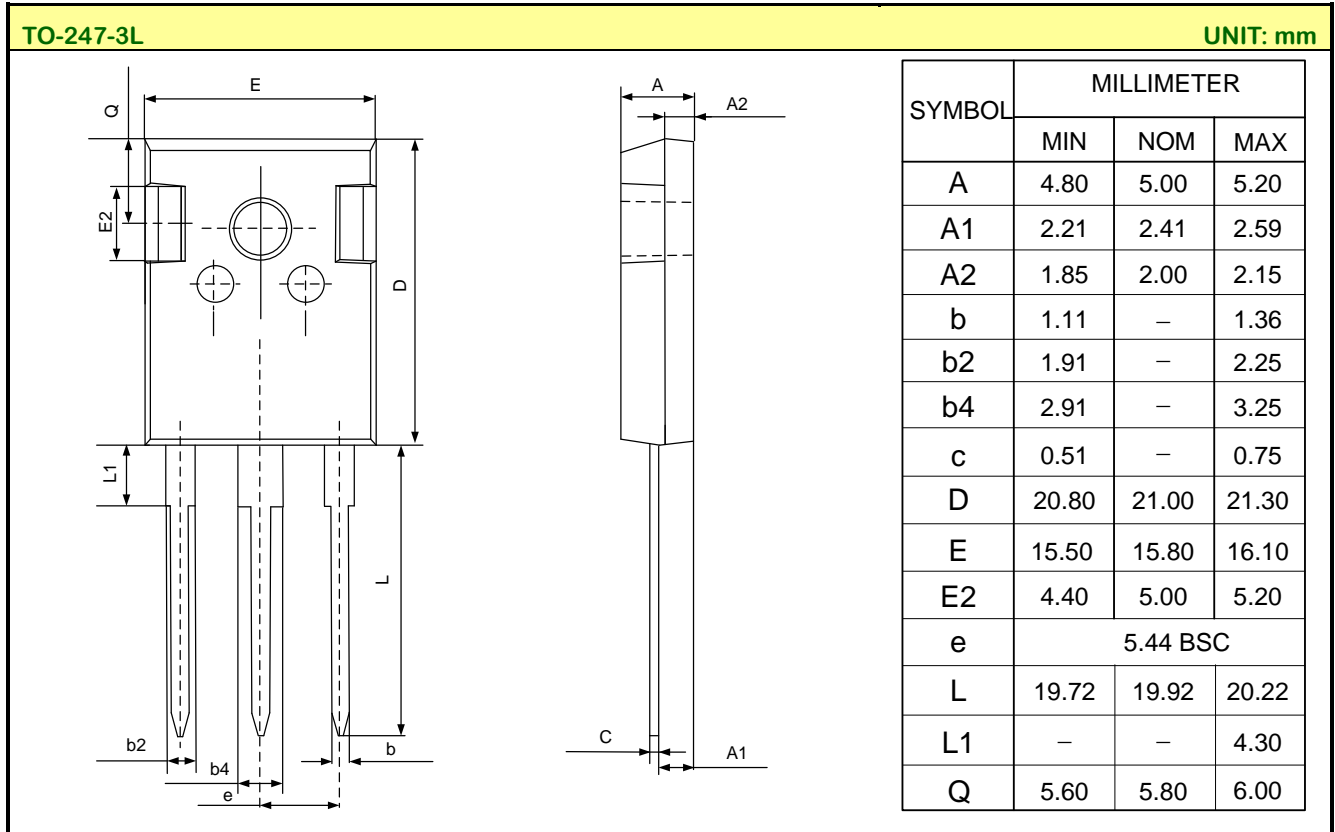

**Important notice :**

1. The instructions are subject to change without notice !
2. Customers should obtain the latest relevant information before placing orders and should verify that such information is complete and current. Please read the instructions carefully before using our products, including the circuit operation precautions.
3. Our products are consumer electronic products or the other civil electronic products.
4. When using our products, please do not exceed the maximum rating of the products, otherwise the reliability of the whole machine will be affected. There is a certain possibility of failure or malfunction of any semiconductor product under specific conditions. The buyer is responsible for complying with safety standards and taking safety measures when using our products for system design, sample and whole machine manufacturing, so as to avoid potential failure risk that may cause personal injury or property loss.
5. It is strongly recommended to identify the trademark when buying our products. Please contact us if there is any question.
6. Product promotion is endless, our company will wholeheartedly provide customers with better products!
7. Website: <http://www.silan.com.cn>



---

Part No.: SGT40T120SDB4P7 Document Type: Datasheet  
Copyright: HANGZHOU SILAN MICROELECTRONICS CO.,LTD Website: <http://www.silan.com.cn>

---

Rev: 1.0

Revision History:

1. First release
-