

120A, 650V FIELD STOP IGBT

DESCRIPTION

The SGTQ120V65SDB1PW field stop IGBT adopts Silan Field Stop 5 technology. It features low conduction loss and switching loss, is applicable to photovoltaic, UPS, SMPS and PFC fields.

FEATURES

- ◆ 120A, 650V, $V_{CE(sat)(typ.)}=1.42V@I_C=120A$
- ◆ Low conduction loss
- ◆ Fast switching
- ◆ High input impedance
- ◆ $T_{Jmax}=175^{\circ}C$

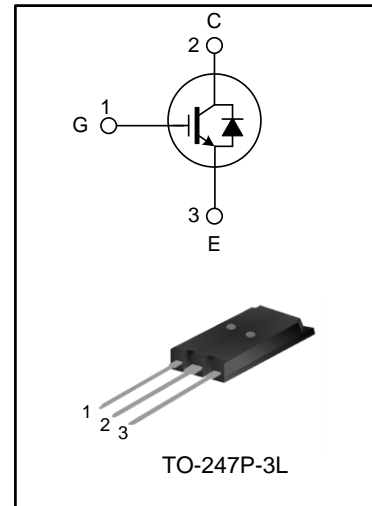

NOMENCLATURE

| SGT Q 120 V 65 S D B 1 PW | |
|--|---|
| IGBT series Automotive Current, 120: 120A N : N-channel NE : N-channel planner gate with ESD T : Field Stop 3/4 U : Field Stop 4+ V : Field Stop 5 W : Field Stop 5+ X : Field Stop 6 Y : Field Stop 7 Voltage, 65: 650V 120: 1200V | Package PW : TO-247P-3L 1,2,3... : Version No. Blank: Standard diode M : Standard diode, full range R : Rapid diode B : Rapid diode, full range S : Ultra soft diode, full range D : packaged with fast recovery diode R : RC IGBT Blank: single IGBT C : SiC L : Ultra low switching, recommended frequency ~2KHz Q : Low switching, recommended frequency 2~20KHz S : Standard frequency, recommended frequency 5~40KHz F : Fast switching, recommended frequency 10~60KHz UF : Ultra fast switching, recommended frequency 40KHz~ I: Igniter |

ORDERING INFORMATION

| Part No. | Package | Marking | Hazardous Substance Control | Packing Type |
|------------------|------------|-------------|-----------------------------|--------------|
| SGTQ120V65SDB1PW | TO-247P-3L | Q120V65SDB1 | Halogen free | Tube |

ABSOLUTE MAXIMUM RATINGS (UNLESS OTHERWISE NOTED, T_C=25°C)

| Characteristics | | Symbol | Ratings | Unit |
|---|-----------------------|------------------|----------|------|
| Collector to Emitter Voltage | | V _{CE} | 650 | V |
| Gate to Emitter Voltage | | V _{GE} | ±20 | V |
| Transient Gate-Emitter Voltage (t _p ≤10μs, D<0.010) | | V _{GE} | ±30 | V |
| Collector Current | T _C =25°C | I _C | 150 | A |
| | T _C =100°C | | 120 | |
| Pulsed Collector Current | | I _{CM} | 360 | A |
| Diode current | T _C =25°C | I _F | 150 | A |
| | T _C =100°C | | 120 | |
| Diode Pulse Current | | I _{FM} | 360 | A |
| Power Dissipation (T _C =25°C) | | P _D | 682 | W |
| Operating Junction Temperature | | T _J | -40~+175 | °C |
| Storage Temperature Range | | T _{stg} | -55~+150 | °C |

THERMAL CHARACTERISTICS

| Characteristics | Symbol | Test conditions | Ratings | | | Unit |
|--|-------------------|---|---------|------|------|------|
| | | | Min. | Typ. | Max. | |
| Thermal Resistance, Junction to Case (IGBT) | R _{θJC} | -- | -- | -- | 0.22 | °C/W |
| Thermal Resistance, Junction to Case (FRD) | R _{θJC} | -- | -- | -- | 0.35 | °C/W |
| Thermal Resistance, Junction to Ambient (IGBT) | R _{θJA} | -- | -- | -- | 40 | °C/W |
| Soldering Temperature (in line) | T _{sold} | 15 ⁺² ₋₀ sec, 1time | -- | -- | 260 | °C |

ELECTRICAL CHARACTERISTICS OF IGBT (UNLESS OTHERWISE NOTED, $T_C=25^\circ\text{C}$)

| Characteristics | Symbol | Test conditions | Min. | Typ. | Max. | Unit |
|---|---------------|--|------|-------|-----------|---------|
| Collector to Emitter Breakdown Voltage | BV_{CE} | $V_{GE}=0V, I_C=1mA$ | 650 | -- | -- | V |
| C-E Leakage Current | I_{CES} | $V_{CE}=650V, V_{GE}=0V$ | -- | -- | 50 | μA |
| G-E Leakage Current | I_{GES} | $V_{GE}=20V, V_{CE}=0V$ | -- | -- | ± 100 | nA |
| G-E Threshold Voltage | $V_{GE(th)}$ | $I_C=1mA, V_{CE}=V_{GE}$ | 4.0 | 5.4 | 6.8 | V |
| Collector to Emitter Saturation Voltage | $V_{CE(sat)}$ | $I_C=120A, V_{GE}=15V, T_C=25^\circ\text{C}$ | -- | 1.42 | 1.8 | V |
| | | $I_C=120A, V_{GE}=15V, T_C=175^\circ\text{C}$ | -- | 1.70 | -- | V |
| Input Capacitance | C_{ies} | $V_{CE}=30V$ $V_{GE}=0V$ $f=1MHz$ | -- | 13269 | -- | pF |
| Output Capacitance | C_{oes} | | -- | 347 | -- | |
| Reverse Transfer Capacitance | C_{res} | | -- | 59 | -- | |
| Turn-On Delay Time | $T_{d(on)}$ | $V_{CE}=400V$ $I_C=120A$ $R_g=5.0\Omega$ $V_{GE}=15V$ inductive load $T_C=25^\circ\text{C}$ | -- | 70 | -- | ns |
| Rise Time | T_r | | -- | 40 | -- | |
| Turn-Off Delay Time | $T_{d(off)}$ | | -- | 322 | -- | |
| Fall Time | T_f | | -- | 60 | -- | |
| Turn-On Switching Loss | E_{on} | $T_C=25^\circ\text{C}$ | -- | 2.80 | -- | mJ |
| Turn-Off Switching Loss | E_{off} | | -- | 3.82 | -- | |
| Total Switching Loss | E_{st} | | -- | 6.62 | -- | |
| Turn-On Delay Time | $T_{d(on)}$ | $V_{CE}=400V$ $I_C=60A$ $R_g=5.0\Omega$ $V_{GE}=15V$ inductive load $T_C=25^\circ\text{C}$ | -- | 67 | -- | ns |
| Rise Time | T_r | | -- | 25 | -- | |
| Turn-Off Delay Time | $T_{d(off)}$ | | -- | 345 | -- | |
| Fall Time | T_f | | -- | 72 | -- | |
| Turn-On Switching Loss | E_{on} | $T_C=25^\circ\text{C}$ | -- | 1.03 | -- | mJ |
| Turn-Off Switching Loss | E_{off} | | -- | 1.97 | -- | |
| Total Switching Loss | E_{st} | | -- | 3.00 | -- | |
| Total Gate Charge | Q_g | $V_{CE}=400V, I_C=120A, V_{GE}=15V$ | -- | 416 | -- | nC |
| Gate to Emitter Charge | Q_{ge} | | -- | 99 | -- | |
| Gate to Collector Charge | Q_{gc} | | -- | 154 | -- | |

ELECTRICAL CHARACTERISTICS OF FRD (T_C=25°C, UNLESS OTHERWISE NOTED)

| Parameter | Symbol | Test conditions | Min. | Typ. | Max. | Unit |
|--------------------------------|------------------|---|------|------|------|------|
| Diode Forward Voltage | V _{FM} | I _F =120A, T _C =25°C | -- | 1.70 | 2.2 | V |
| | | I _F =120A, T _C =175°C | -- | 1.65 | -- | |
| Diode Reverse Recovery Time | T _{rr} | V _R =400V, I _F =120A, R _g =5.0Ω, T _C =25°C | -- | 228 | -- | ns |
| Diode Reverse Recovery Charge | Q _{rr} | | -- | 5.3 | -- | μC |
| Diode Reverse Recovery Current | I _{rrm} | | -- | 43 | -- | A |
| Diode Reverse Recovery Loss | E _{rec} | | -- | 1.9 | -- | mJ |

ELECTRICAL CHARACTERISTICS OF IGBT (T_C=175°C)

| Parameter | Symbol | Test conditions | Min. | Typ. | Max. | Unit |
|-------------------------|---------------------|--|------|------|------|------|
| Turn-On Delay Time | T _{d(on)} | V _{CE} =400V I _C =120A R _g =5.0Ω V _{GE} =15V inductive load T _C =175°C | -- | 67 | -- | ns |
| Rise Time | T _r | | -- | 48 | -- | |
| Turn-Off Delay Time | T _{d(off)} | | -- | 378 | -- | |
| Fall Time | T _f | | -- | 118 | -- | |
| Turn-On Switching Loss | E _{on} | T _C =175°C | -- | 3.10 | -- | mJ |
| Turn-Off Switching Loss | E _{off} | | -- | 5.53 | -- | |
| Total Switching Loss | E _{st} | | -- | 8.63 | -- | |
| Turn-On Delay Time | T _{d(on)} | V _{CE} =400V I _C =60A R _g =5.0Ω V _{GE} =15V inductive load T _C =175°C | -- | 62 | -- | ns |
| Rise Time | T _r | | -- | 30 | -- | |
| Turn-Off Delay Time | T _{d(off)} | | -- | 438 | -- | |
| Fall Time | T _f | | -- | 122 | -- | |
| Turn-On Switching Loss | E _{on} | T _C =175°C | -- | 1.21 | -- | mJ |
| Turn-Off Switching Loss | E _{off} | | -- | 3.10 | -- | |
| Total Switching Loss | E _{st} | | -- | 4.31 | -- | |

ELECTRICAL CHARACTERISTICS OF FRD ($T_C=175^\circ\text{C}$)

| Parameter | Symbol | Test conditions | Min. | Typ. | Max. | Unit |
|--------------------------------|-----------|--|------|------|------|---------------|
| Diode Reverse Recovery Time | T_{rr} | $V_R=400\text{V}$, $I_F=120\text{A}$, $R_g=5.0\Omega$, $T_C=175^\circ\text{C}$ | -- | 282 | -- | ns |
| Diode Reverse Recovery Charge | Q_{rr} | | -- | 13.4 | -- | μC |
| Diode Reverse Recovery Current | I_{rrm} | | -- | 79 | -- | A |
| Diode Reverse Recovery Loss | E_{rec} | | -- | 4.46 | -- | mJ |

TYPICAL CHARACTERISTICS

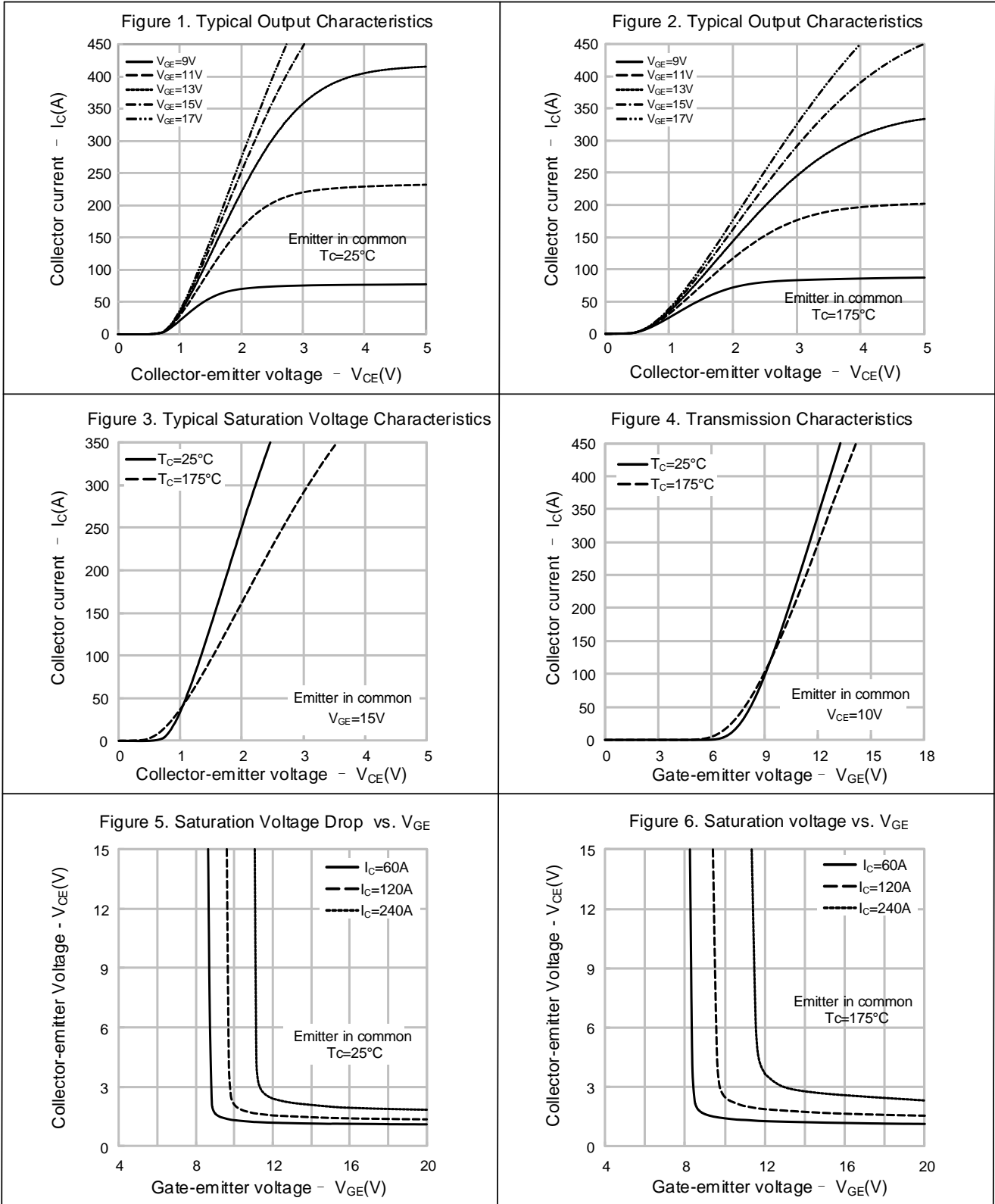

TYPICAL CHARACTERISTICS (CONTINUED)

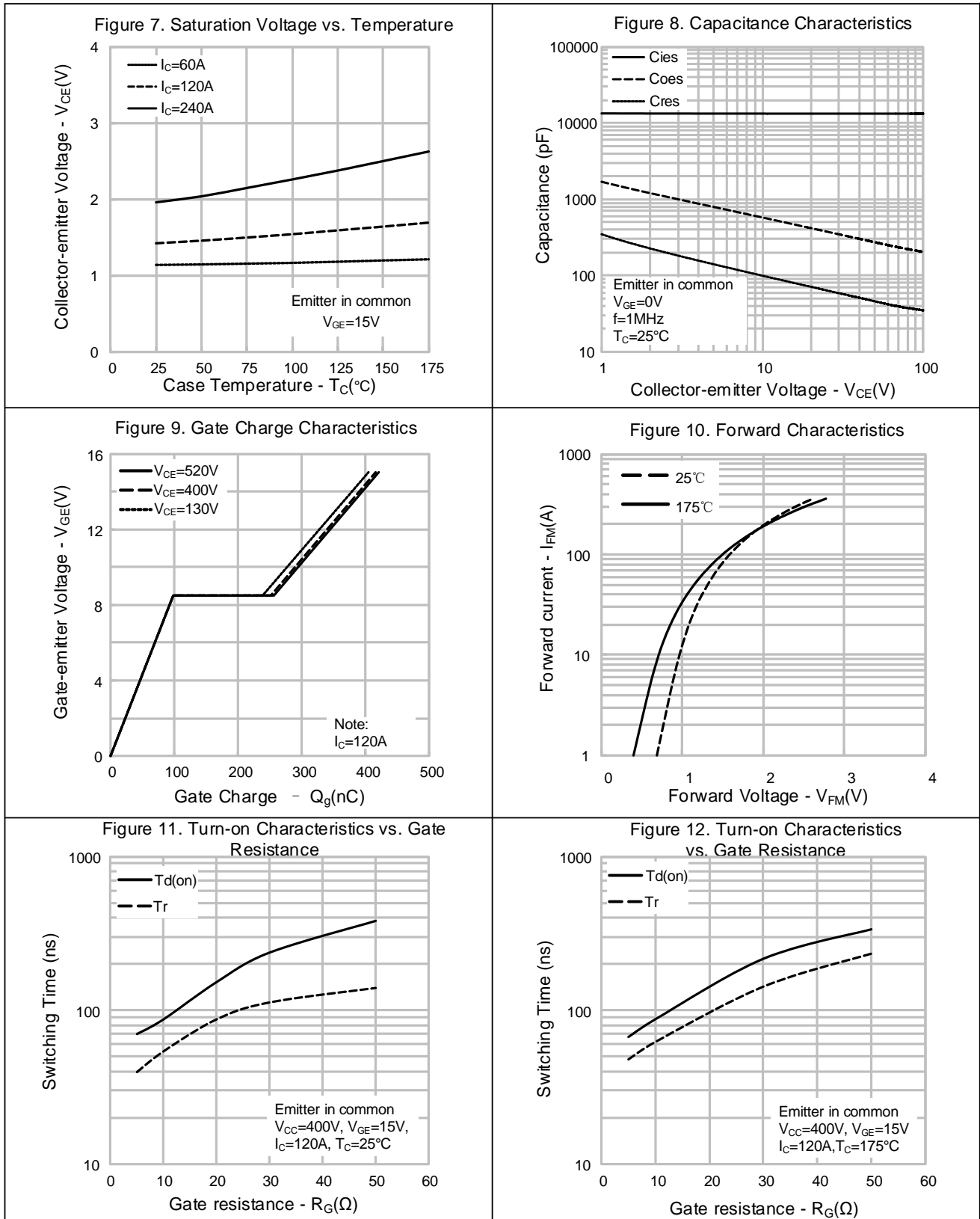

TYPICAL CHARACTERISTICS (CONTINUED)

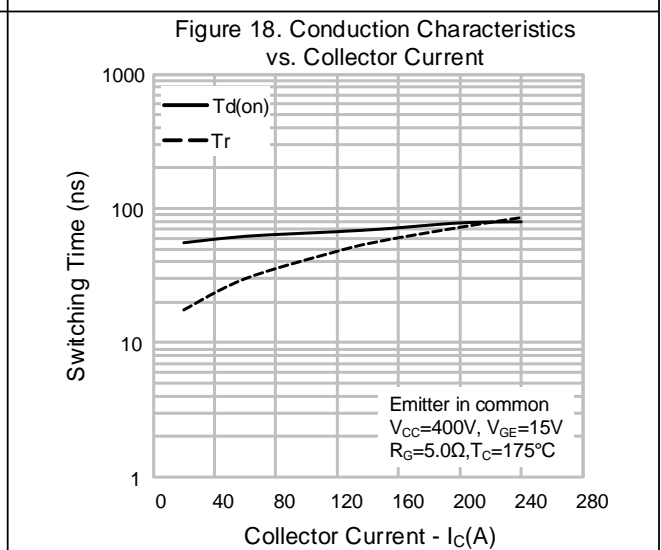
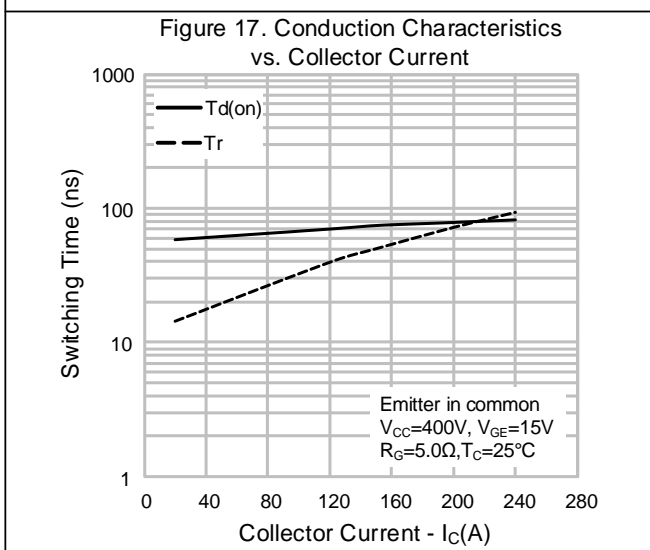
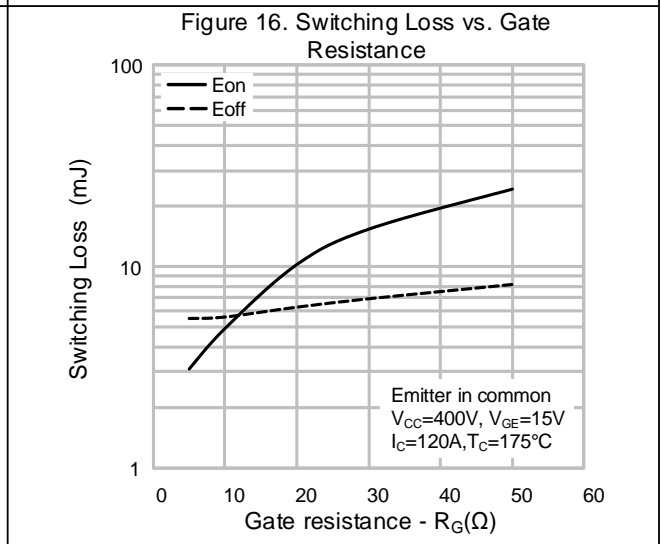
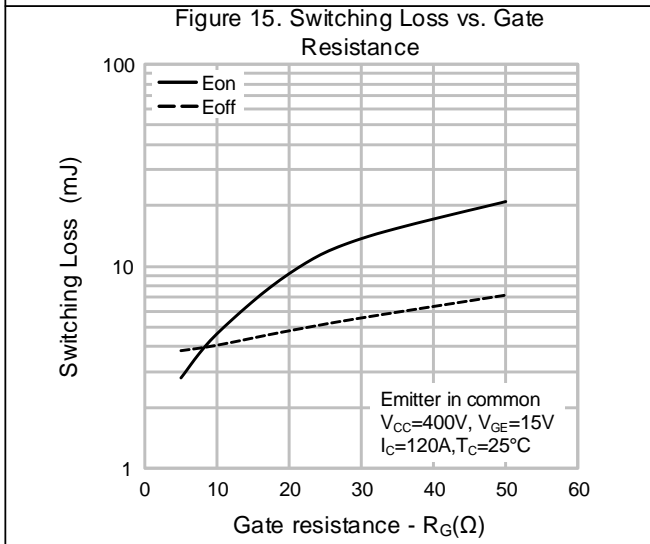
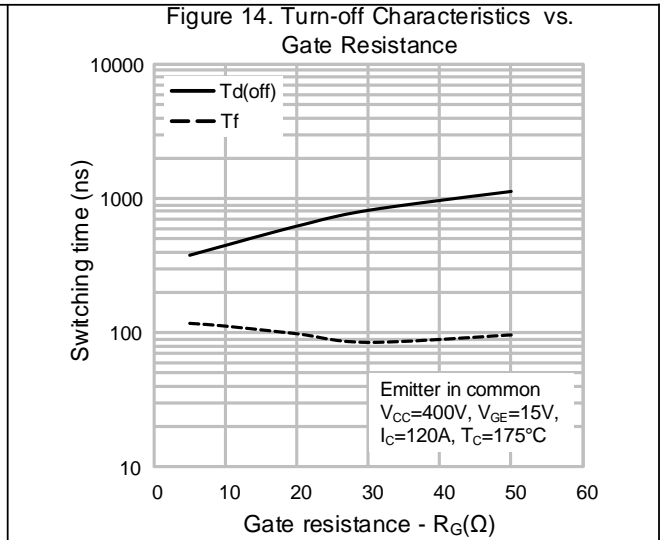
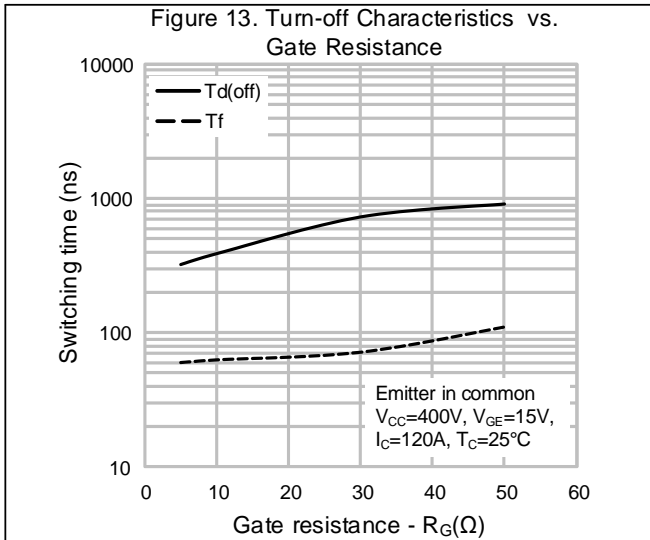

TYPICAL CHARACTERISTICS (CONTINUED)

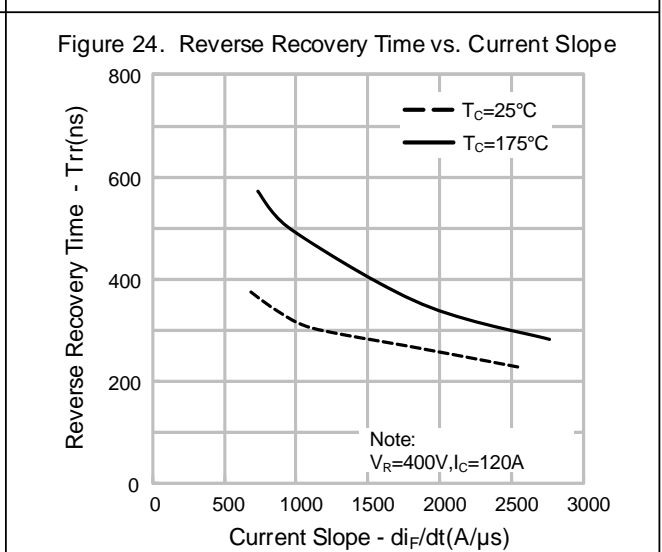
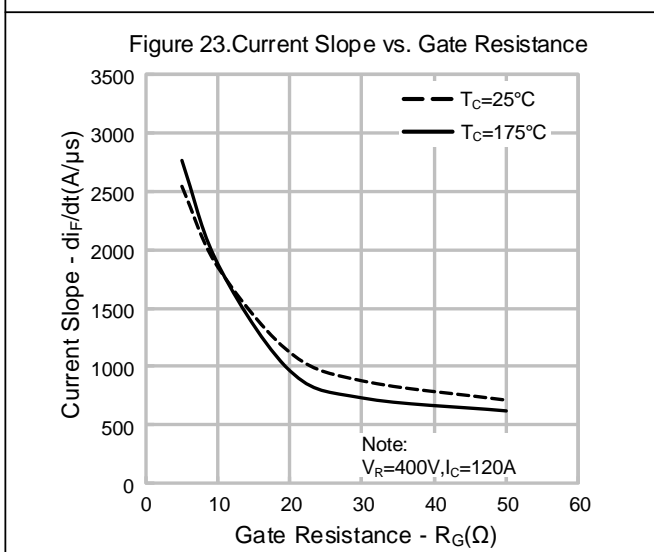
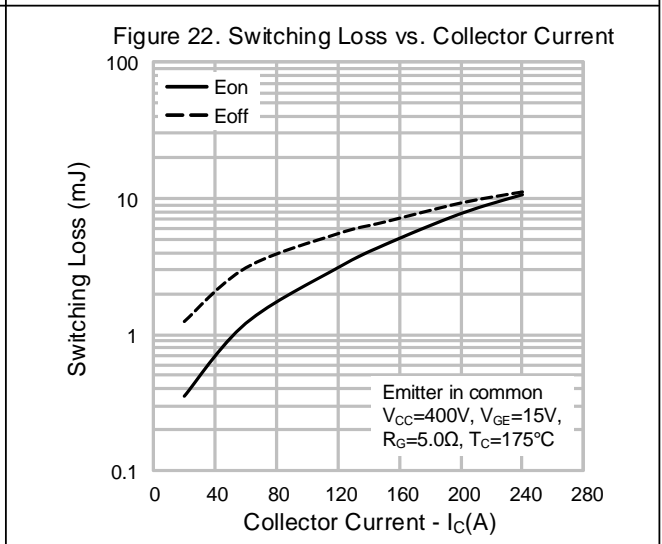
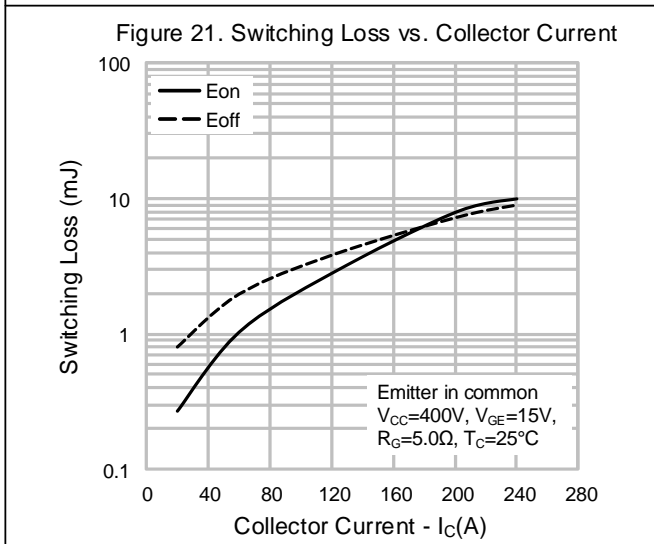
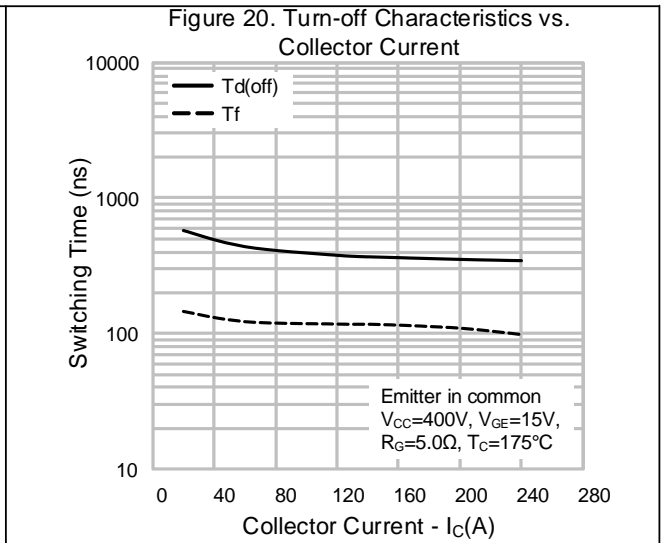
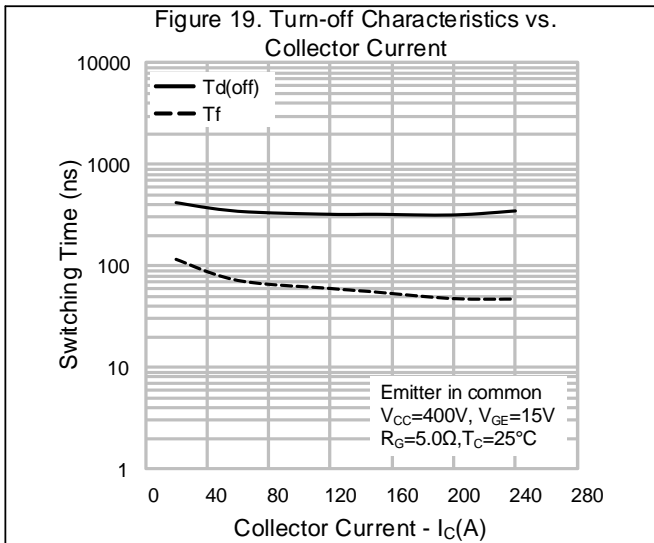

TYPICAL CHARACTERISTICS (CONTINUED)

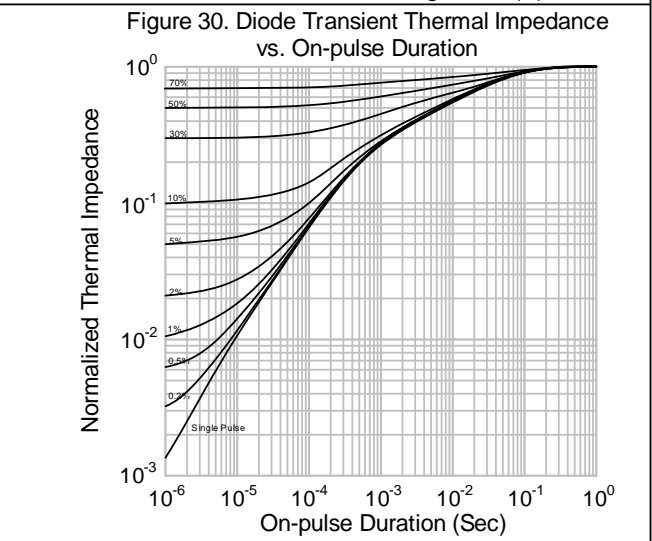
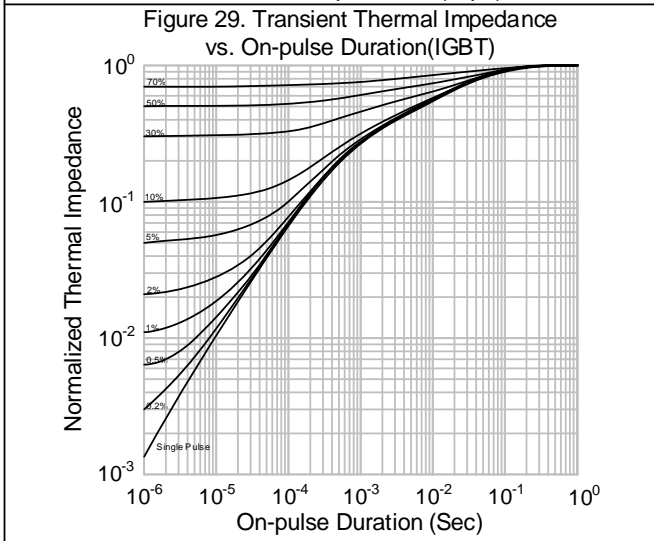
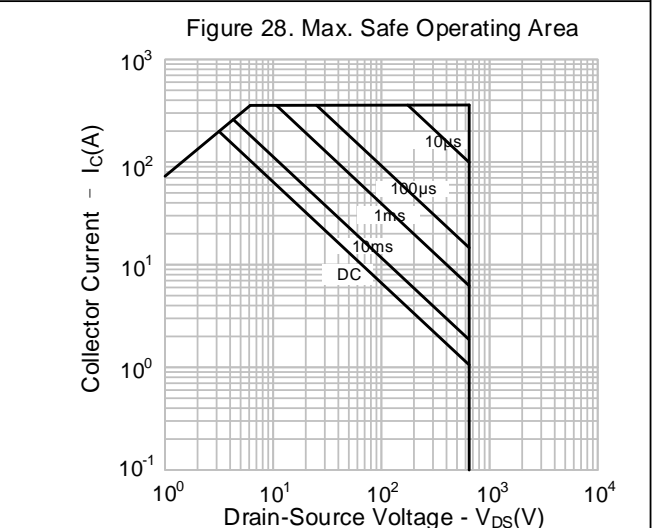
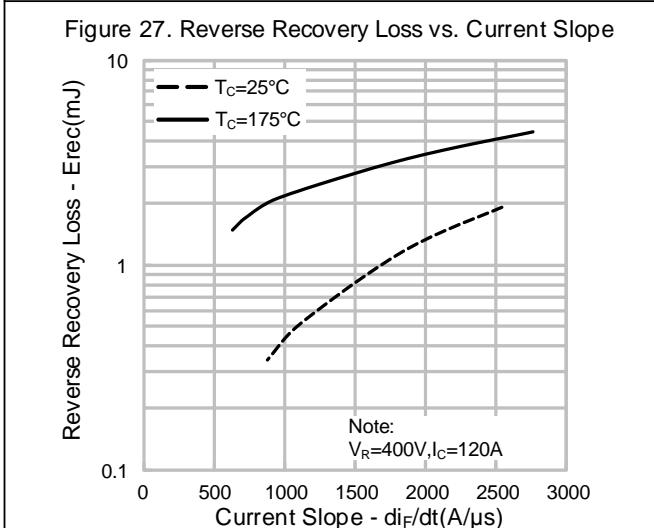
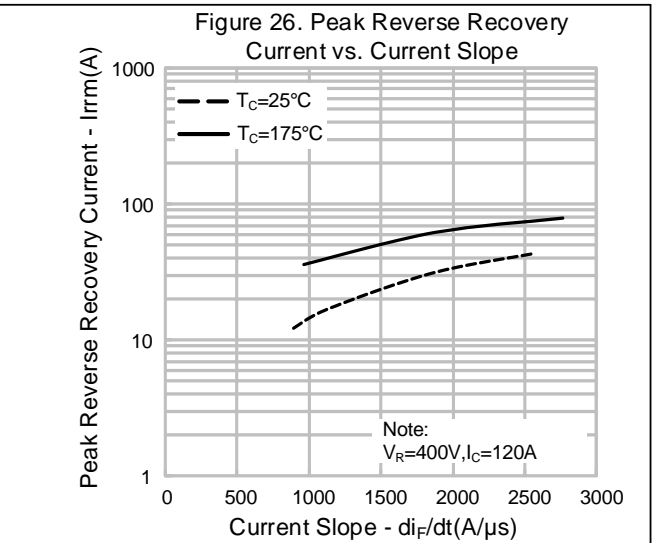
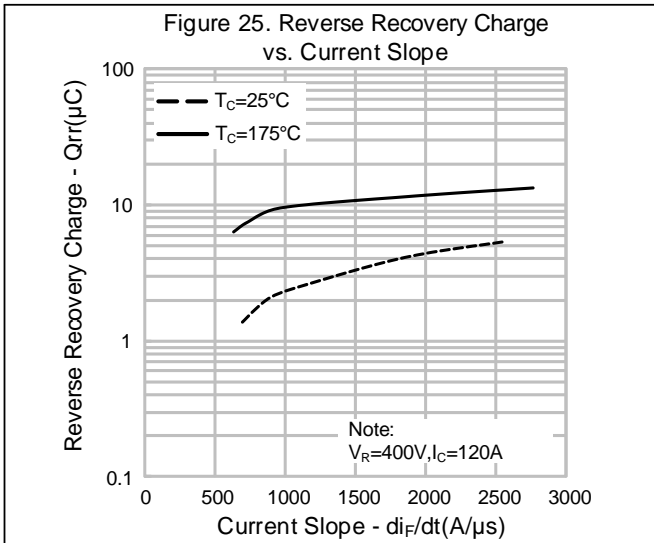

PACKAGE OUTLINE

TO-247P-3L

UNIT: mm

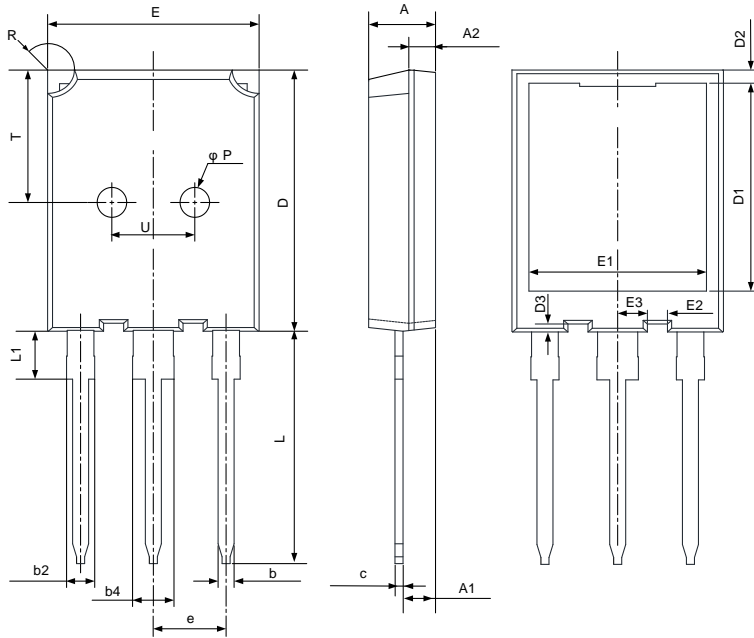

| SYMBOL | MILLIMETER | | |
|--------|------------|-------|-------|
| | MIN | NOM | MAX |
| A | 4.90 | 5.00 | 5.10 |
| A1 | 2.31 | 2.41 | 2.51 |
| A2 | 1.90 | 2.00 | 2.10 |
| b | 1.16 | — | 1.26 |
| b2 | — | — | 2.25 |
| b4 | — | — | 3.25 |
| c | 0.59 | — | 0.66 |
| D | 20.90 | 21.00 | 21.10 |
| D1 | 16.25 | 16.55 | 16.85 |
| D2 | 1.05 | 1.17 | 1.35 |
| D3 | 0.58 | — | 0.78 |
| e | 5.436 BSC | | |
| E | 15.70 | 15.80 | 15.90 |
| E1 | 13.10 | 13.30 | 13.50 |
| E2 | 1.40 | 1.50 | 1.60 |
| E3 | 2.12 | 2.22 | 2.32 |
| L | 19.80 | 19.95 | 20.10 |
| L1 | — | — | 4.30 |
| T | 9.80 | — | 10.20 |
| P | 2.40 | 2.50 | 2.60 |
| U | 6.00 | — | 6.40 |
| R | 1.90 | — | 2.10 |



MOS DEVICES OPERATE NOTES:

Electrostatic charges may exist in many things. Please take following preventive measures to prevent effectively the MOS electric circuit as a result of the damage which is caused by discharge:

- The operator must put on wrist strap which should be earthed to against electrostatic.
- Equipment cases should be earthed.
- All tools used during assembly, including soldering tools and solder baths, must be earthed.
- MOS devices should be packed in antistatic/conductive containers for transportation.

Important notice:

1. Silan reserves the right to make changes of this instruction without notice.
2. Customers should obtain the latest relevant information when purchasing and should verify whether such information is latest and complete. Please read this instruction and application manual and related materials carefully before using products, including the circuit operation precautions, etc.
3. Silan does not give any warranties as to the suitability of the Silan's product for any specific use. The design intent, design definition and design of the product are not intended for application (the application stated in this instruction includes use, etc.) in medical equipment, life-saving equipment, aerospace equipment, non-civil equipment or non-civil use, etc. (the equipment stated in this instruction includes systems, devices, etc., all referred to as equipment). The product should not be used in any equipment or system whose manufacture, use or sale is prohibited under any applicable laws or regulations ("unintended use"). If the product is used for unintended use, therefore the full risks of such products application are borne by the customer and Silan assumes no liability for the product used for the unintended use. If the customer intends to use the Silan's product in a application where malfunction or failure can be reasonably be expected to result in personal injury, or serious property, or environment damage, the customer shall make adequate assessment, testing and verification, and Silan shall not be liable for such applications.
4. The application of the product described in this instruction, the application manual of the product and related materials is for illustrative purposes only, and Silan makes no warranty that such application can be used directly without further testing, verification or modification. Silan is not responsible for any assistance in product application or customers' product design. Customer shall be responsible for the application of Silan's products and the design, manufacture and use of customers' products using Silan's products (in this document, "use products", "apply Silan's products", "product application" and "customers' products using Silan's products" are synonymous). It is the sole responsibility of the customer to take the following actions: 1) Verify and determine whether Silan's products are suitable for the customers' applications and customers' products; 2) All applicable standards of the customers' industry shall be complied with and fully tested and verified when applying Silan's product or using Silan's product to develop and design customers' products; 3) Although Silan is constantly committed to improve product's quality and reliability, semiconductor products have possibility to malfunction or fail in various application environments. Customers are responsible for complying with safety standards and for providing adequate designs and safeguards for customers' products using Silan's product to minimize risks and avoid situations in which a malfunction or failure could cause bodily injury or damage to property; 4) When using the products, please do not exceed the maximum rating of the products, Stress above one or more limiting values will cause damage to the product and the equipment or affect the reliability to the equipment (customers' product); 5) Ensure customers' product using Silan's product are designed, manufactured and used in full compliance with all applicable standards, safety standards and other requirements of the customers' industry. The parameters stated in this instruction may and do vary in different applications, actual performance may vary over time. Customers must use the products within their effective static storage period, please contact Silan sales or Silan customer service support and sales management department if there is any questions about the effective static storage period, Silan does not assume any responsibility if the product has exceeded the static storage period when it is used.
5. Do not disassemble, reverse-engineer, alter, modify, decompile or copy product, without Silan's prior written consent.
6. Please identify Silan's trademark when purchasing our product. Please contact us if there is any question. Our products are not sold through TAOBAO or any other third-party e-commerce platforms. If customers purchase from such platforms, please contact us in writing before purchasing to confirm whether the product is authentic and original from Silan.
7. Please use and apply product in compliance with all applicable laws and regulations, including but not limited to trade control regulations etc. The product is civil electronic product, please do not use it in non-civil fields.
8. Product promotion is endless, our company will wholeheartedly provide customers with better products!
9. Website: <http://www.silan.com.cn>

Part No.: SGTQ120V65SDB1PW Document Type: Datasheet
Copyright: HANGZHOU SILAN MICROELECTRONICS CO.,LTD Website: <http://www.silan.com.cn>

Rev: 1.0

Revision History:

1. First release
-