

**Ordering Code :**

<b>S</b>	<b>34</b>	<b>AR</b>	<b>550</b>
<b>A</b>	<b>B</b>	<b>C</b>	<b>D</b>

SELECT	Code
A) Type of Diode	Rectifier S Fast Recovery SF
B) Voltage Class	V <sub>RRM</sub> required divided by 100 e.g. 15 will indicate 1500 volts V <sub>RRM</sub>
C) Outline Package	
1) Tophat normal polarity	AN, BN, DN, DBN, HN, HBN, HFN & HNS
2) Tophat reverse polarity	AR, BR, DR, DBR, HR, HBR, HFR & HRS
3) Capsule	C
D) Current	Average forward current in Amperes

**DEVICE & HEAT SINK SELECTION :**

Consider a single phase full wave bridge having a D.C. output of 500 Amps.

$$\text{The current per device} = \frac{500}{2} = 250 \text{ Amps}$$

You may therefore choose a device with a suitable I<sub>F</sub> (AV), with some safety margin. Say type HN 400 Ensure that the I<sup>2</sup>t of the device meets the circuit fusing requirements.

The power loss P<sub>w</sub> of the device:

$$P_w = V_o \times I_F(av) + I_{(RMS)}^2 \times r$$

Where:

V <sub>o</sub>	= Threshold voltage (taken from catalogue)
I <sub>F</sub> (av)	= Average forward current.
I <sub>(RMS)</sub>	= I <sub>F</sub> (AV) × Form factor (Form factor single for phase system & Resistive Load = 1.57)
r	= Forward Conduction Slope Resistance in ohms.
P <sub>w</sub>	= 0.75 × 250 + (250 × 1.57) <sup>2</sup> × .00035 = 187.5 + 53.9 = Say 242 watts

To evaluate maximum permissible thermal resistance of the Heat Sink; use following formula

$$T_j = T_{amb} + P_w \{ (R_{th}(j-c) + R_{th}(c-hs) + R_{th}(hs-amb)) \}$$

Where

T <sub>j</sub>	= Maximum allowable junction temperature.
P <sub>w</sub>	= Calculated power loss
T <sub>amb</sub> .	= Ambient Temperature (T <sub>o</sub> be taken worst = 55°C)
R <sub>th</sub> (j-c)	= Thermal Resistance Junction to case (taken from catalogue)
R <sub>th</sub> (c-hs)	= Thermal resistance case to heat sink (taken from catalogue)

R<sub>th</sub> (hs-amb) = Thermal Resistance Heat Sink to ambient.

Taking a safety of 3°C, for device type HN 400, maximum allowable T<sub>j</sub> = 167°C.

$$\therefore 167 = 55 + 242 (0.11 + 0.05 + R_{th}(hs-amb))$$

$$\therefore R_{th}(hs-amb) = 0.302^\circ\text{C/W}$$

Therefore, the heat sink should have R<sub>th</sub> less than 0.302 C/Watt.

**Note:** VRSM =non repetitive voltage is 100 volts more than rated VRRM grade of device .

## RECTIFIER DIODES (TOP HAT TYPES) :

Diode Type	V <sub>RRM</sub> Range V	I <sub>F</sub> (av) A	T <sub>case</sub> °C	I <sub>F</sub> (RMS) A	I <sub>F</sub> (DC) A	I <sub>FSM</sub> 10m Sec A	I <sup>2</sup> t A <sup>2</sup> Sec	R <sub>th(j-c)</sub> 180°Si °C/W	R <sub>th(c-h)</sub> °C/W
SXHN6	200-1500	6	120	9.5	9.5	200	0.2×10 <sup>3</sup>	4.5	0.6
SXHN14	200-1500	12	120	19	19	250	0.312×10 <sup>3</sup>	2.1	0.6
SXHN16	200-1500	16	120	25	25	300	0.45×10 <sup>3</sup>	1.5	0.25
SXHN20	200-1500	20	120	32	32	350	0.612×10 <sup>3</sup>	1.3	0.25
SXHN25	200-1500	25	120	40	40	400	0.8×10 <sup>3</sup>	0.8	0.25
SXHN40	200-1500	40	120	63	63	500	1.25×10 <sup>3</sup>	0.75	0.25
SXHN55	200-1500	55	120	86	86	1000	5.0×10 <sup>3</sup>	0.5	0.15
SXBN71	200-1500	70	120	110	110	1200	7.2×10 <sup>3</sup>	0.4	0.15
SXDN:HN100	200-1500	100	115	157	157	1800	16.2×10 <sup>3</sup>	0.49	0.08
SXHNS100	200-1500	100	120	160	160	2400	28.8×10 <sup>3</sup>	0.24	0.05
SXAN/HN125	200-1500	150	125	235	235	4000	80×10 <sup>3</sup>	0.24	0.05
SXHNS150	200-1500	150	125	200	200	4000	80×10 <sup>3</sup>	0.24	0.05
SXDBN/HBN150	200-1500	150	125	235	235	4000	80×10 <sup>3</sup>	0.24	0.05
SXHNS170	200-1500	170	120	270	270	4000	80×10 <sup>3</sup>	0.24	0.05
SXAN/HN200	200-1500	200	125	300	300	4200	88×10 <sup>3</sup>	0.18	0.05
SXHNS250	200-1500	250	125	392	392	5000	125×10 <sup>3</sup>	0.18	0.05
SXHN300	200-1000	300	125	471	471	6000	180×10 <sup>3</sup>	0.127	0.05
SXHNS320	1000-1800	320	105	500	500	5500	151×10 <sup>3</sup>	0.15	0.04
SXHN/HFN350	200-1500	350	125	430	430	6300	198×10 <sup>3</sup>	0.12	0.05/0.02
SXHN400	200-1000	400	125	628	628	7500	281×10 <sup>3</sup>	0.11	0.05
SXAN550	2800-4000	550	100	865	865	12500	781×10 <sup>3</sup>	0.092	0.02
SXAN680	1800-2600	680	80	1070	1070	14000	980×10 <sup>3</sup>	0.09	0.02
SXAN 800	200-1800	800	90	1260	1260	20500	2101×10 <sup>3</sup>	0.077	0.02
SXAN1000	200-800	1000	120	1570	1570	25000	3125×10 <sup>3</sup>	0.063	0.02

## RECTIFIER DIODES (CAPSULE TYPES) :

Diode Type	V <sub>RRM</sub> Range V	I <sub>F</sub> (av)/T <sub>case</sub> A/°C	I <sub>F</sub> (RMS) A	I <sub>F</sub> (DC) A	I <sub>FSM</sub> 10 m Sec A	I <sup>2</sup> t A <sup>2</sup> Sec	I <sub>RRM</sub> mA	V <sub>O</sub> V	m
SHXXC450	200-800	450/120	700	700	4900	120×10 <sup>3</sup>	20	0.7	0.4
SHXXC500	200-2600	500/85	785	785	5500	151×10 <sup>3</sup>	50	0.85	0.6
SHXXC540	200-1800	540/91	850	850	6000	180×10 <sup>3</sup>	50	0.75	0.6
SHXXC675	200-2800	675/100	1060	1060	7500	281×10 <sup>3</sup>	60	0.8	0.6
SHXXC700	200-1800	700/100	1100	1100	8000	320×10 <sup>3</sup>	50	0.85	0.4
SHXXC760	200-800	760/104	1200	1200	8500	361×10 <sup>3</sup>	25	0.7	0.3
SHXXC800	200-2800	800/83	1260	1260	9000	405×10 <sup>3</sup>	40	0.8	0.5
SHXXC960	3600-4800	960/52	1500	1500	10500	551×10 <sup>3</sup>	50	0.9	0.6
SHXXC1115	2800-4000	1115/67	1750	1750	12500	781×10 <sup>3</sup>	50	0.81	0.5
SHXXC1130	200-1800	1130/65	1775	1775	12700	806×10 <sup>3</sup>	30	0.75	0.3
SHXXC1250	1800-3000	1250/79	1960	1960	14000	980×10 <sup>3</sup>	40	0.78	0.3
SHXXC1850	200-1800	1850/43	2900	2900	20500	288×10 <sup>4</sup>	40	0.74	0.2
SHXXC2230	200-800	2230/109	3500	3500	25000	312×10 <sup>4</sup>	50	0.7	0.1
SHXXC2300	2800-4800	2300/71	3600	3600	25500	325×10 <sup>4</sup>	100	0.88	0.2
SHXXC3200	2000-2800	3200/52	5000	5000	34000	578×10 <sup>4</sup>	150	0.8	0.1
SHXXC3500	200-800	3500/120	5500	5500	39000	760×10 <sup>4</sup>	50	0.7	0.0
SHXXC5600	200-800	5600/68	8792	8792	65000	211×10 <sup>5</sup>	100	0.7	0.0
SHXXC5800	200-800	5800/109	9100	9100	65000	211×10 <sup>5</sup>	100	0.7	0.0

RRM mA	V <sub>peak</sub> V	I <sub>peak</sub> A	T <sub>j</sub> °C	V <sub>f(av)</sub> mV	V <sub>o</sub> V	r mΩ	Weight Gms.	Mounting Torque Kg.M	Figure
2	1.3	20	160	550	0.89	20	9	0.2-0.25	1
2	1.5	38	160	600	1.12	8.77	9	0.2-0.25	1
4	1.55	50	160	550	0.9	14	9	0.2-0.25	1
4	1.5	63	160	560	0.85	11	9	0.2-0.25	1
4	1.25	78	160	550	0.85	4.83	25	0.25-0.35	2
4	1.25	125	160	550	0.78	3.8	25	0.25-0.35	2
8	1.35	172	160	550	1.0	2.36	47	0.4-0.48	3
10	1.35	220	160	550	0.85	2.15	47	0.4-0.48	3
20	1.15	300	170	480	0.8	1.25	100	1.25-1.45	12/4
20	1.3	314	170	550	0.95	1.12	200	1.25-1.45	5
30	1.25	470	170	550	0.72	1.12	125	1.66-2.07	13/6
20	1.25	470	170	550	0.72	1.12	200	1.25-1.45	5
30	1.25	470	170	550	0.72	1.12	125	1.66-2.07	14/7
20	1.3	540	170	550	0.72	1.0	200	1.25-1.45	5
30	1.3	630	170	550	0.7	0.95	125	1.66-2.07	13/6
50	1.3	785	180	550	0.75	0.7	250	1.45-1.7	8
50	1.2	1000	170	600	0.85	0.4	525	1.66-2.07	9
40	1.45	1000	170	600	0.62	0.82	300	2.5-2.77	10
50	1.15	1050	170	600	0.75	0.36	525	1.66-2.07	9/11
40	1.12	1050	180	600	0.75	0.35	525	1.66-2.07	9
50	1.65	1500	160	-	0.81	0.5	810	1.66-2.07	15
40	1.48	2100	160	-	0.78	0.3	950	1.66-2.07	16
40	1.36	2500	160	-	0.74	0.2	950	1.66-2.07	16
50	1.06	3000	180	-	0.7	0.1	950	1.66-2.07	16

Earlier Types SxBR25 & Sx BR 8 are available on request.  
Diodes available in both Normal & Reverse Polarities.  
Base Cathode for Normal Polarity  
Base Anode for Reverse Polarity

	V <sub>peak</sub> V	I <sub>peak</sub> A	T <sub>j</sub> °C	R <sub>th(j-c)</sub> 180°Sin °C/W	Weight Gms.	Mounting Force KN	Figure No
2	1.42	1500	180	0.112	70	3.3-4.5	17
5	1.7	1200	160	0.09	70	3.3-5.5	17
5	1.85	1600	170	0.09	70	3.3-5.5	17
8	1.68	1350	180	0.06	90	5.5-8	18
6	1.45	1350	170	0.06	90	5.5-8	18
	1.39	2000	180	0.079	70	4.0-6	17
5	1.96	2000	150	0.044	340	8-12	18
4	2.9	3000	150	0.042	340	12-18	19
	2.38	3000	160	0.038	340	12-18	19
3	1.83	3000	150	0.045	90	8-12	18
	1.74	3000	160	0.038	340	12-18	19
	1.44	3000	160	0.038	340	12-18	19
	1.28	5000	180	0.0255	340	12-18	19
45	2.09	5000	160	0.017	600	30-45	20
5	1.64	5000	160	0.017	600	30-45	20
61	1.3	8000	180	0.014	600	24-36	19/20
37	1.06	8000	180	0.0165	600	30-45	20
37	1.00	8000	180	0.01	600	40-60	20

In the interest of product improvement  
I direct reserve the right to change  
specifications at  
any time without notice.

Figure No. 1

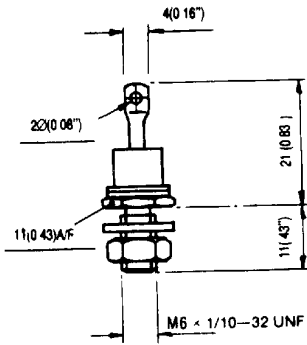

SXHN 6  
SXHN 14  
SXHN 16  
SXHN 20

Figure No. 2

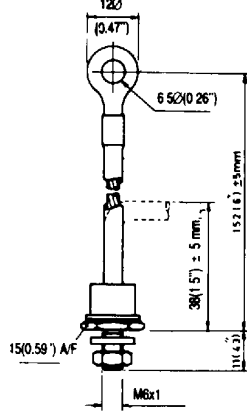

SXHN 25  
SXHN 40

Figure No. 3

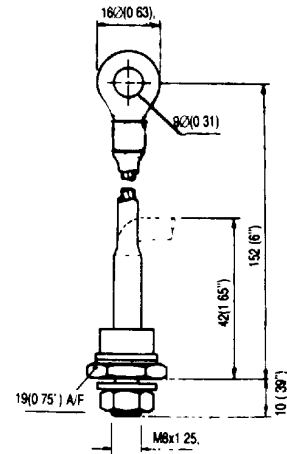

SXHN 55  
SX BN 71

Figure No. 4

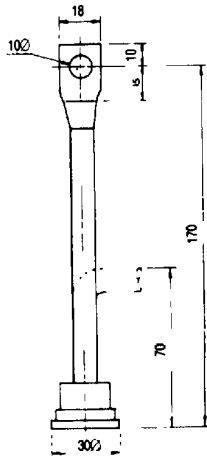

SXHN 100

Figure No. 5

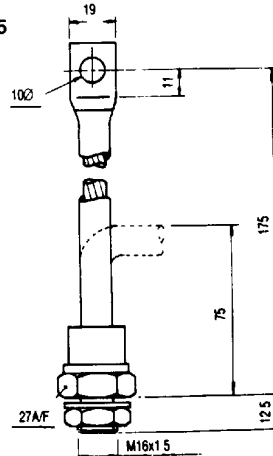

SXHNS 100  
SXHNS 150  
SXHNS 170

Figure No. 6

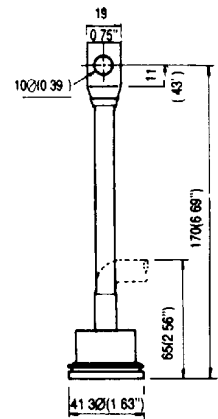

SXHN 125  
SXHN 200

Figure No. 7

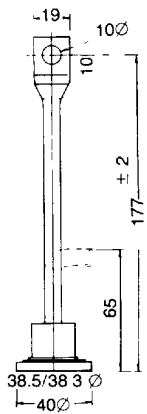

SXHBN 150

Figure No. 8

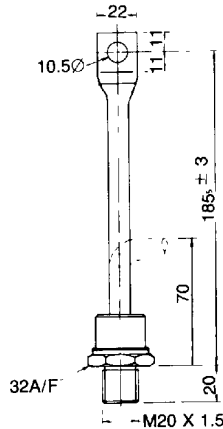

SXHNS 250

Figure No. 9

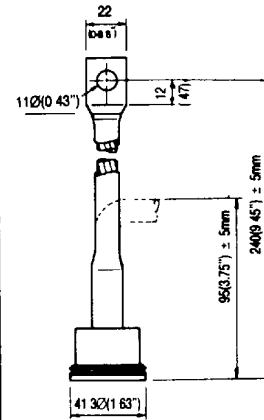

SXHN 300  
SXHN 350  
SXHN 400

Figure No. 10

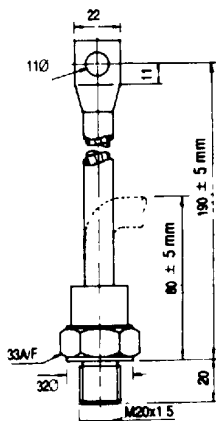

SXHNS320

Figure No. 11

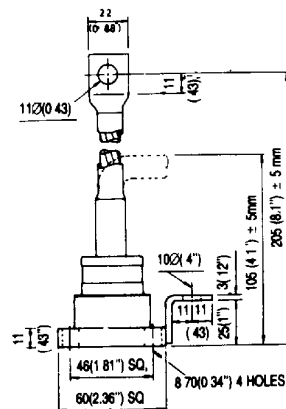

SXHFN 350

Figure No. 12

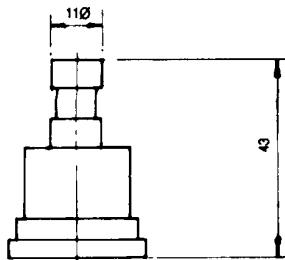

SXDN 100

Figure No. 13

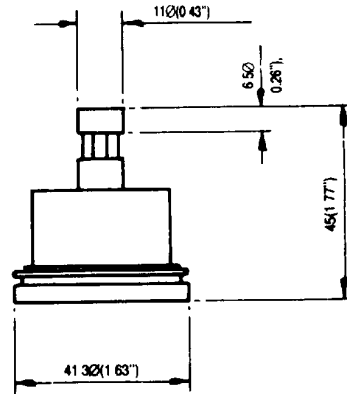

SXAN 125  
SXAN 200

Figure No. 14

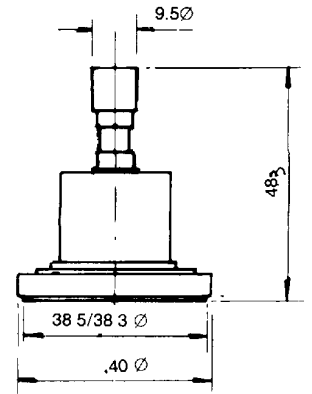

SXDBN 150

Figure No. 15

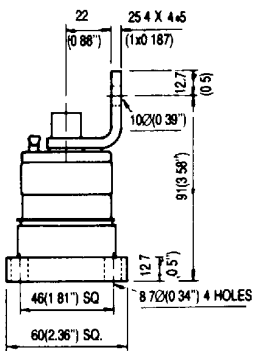

SXAN 550

Figure No. 16

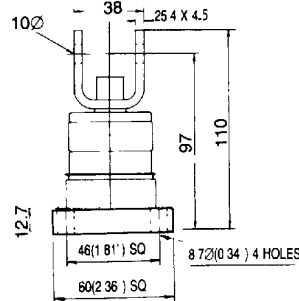

SXAN 680  
SXAN 800  
SXAN 1000

Figure No. 17

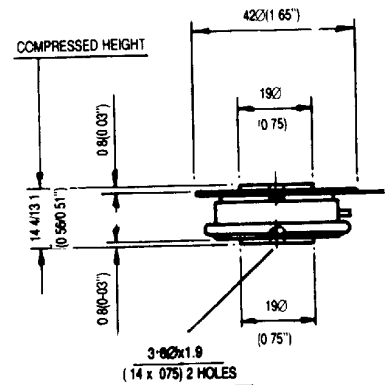

SHXXC 450  
SHXXC 500  
SHXXC 540  
SHXXC 760

Figure No. 18

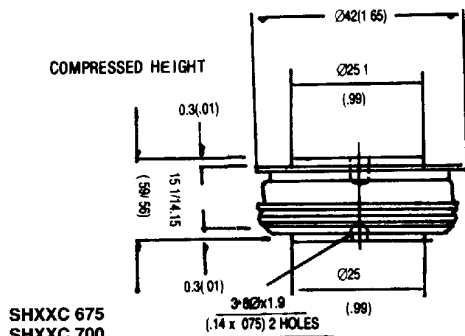

SHXXC 675  
SHXXC 700  
SHXXC 800  
SHXXC 1130

Figure No. 19

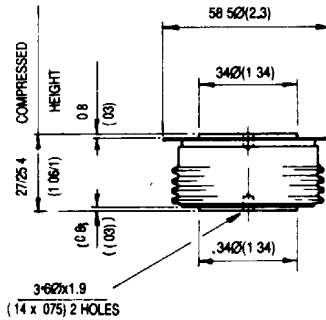

SHXXC 960  
SHXXC 1115  
SHXXC 1250  
SHXXC 1850  
SHXXC 2230  
SHXXC 3500

Figure No. 20

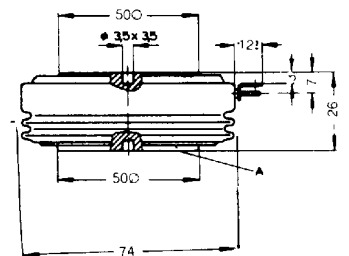

SHXXC 2300  
SHXXC 3200  
SHXXC 3500  
SHXXC 5600  
SHXXC 5800



**HIND RECTIFIERS LTD.,**

Marketing Division, Lake Road, Bhandup, Bombay 400 078. Tel.: 564 2432, 564 2433, 564 2460

Gram : HINDRECT, Telex : 011-72105. HIRT IN, Fax : 022-5600133

**BANGALORE :**  
Office No. 114, 1st floor  
Richmond Tower  
12, Richmond Road  
Bangalore 560 025  
Tel.: 213489  
Gram : HIRECT  
Telex : 0845-8601  
(Address to OM-15)

**CALCUTTA :**  
Chatterjee International Centre  
15th floor, Flat No. 10  
33A Jawaharlal Nehru Road  
Calcutta 700 071  
Tel.: 297546, 297532  
Gram : HINDRECT  
Telex : 021-4840 HIRT IN

**MADRAS :**  
No. 2 Raja Annamalai Road  
Purasawalkam  
Madras - 600 084  
Tel.: 6412017, 6412696  
Gram : HINDRECT  
Telex : 041-7368 HIRT IN

**NEW DELHI :**  
62 Dayanand Road  
Daryaganj  
New Delhi 110 002  
Tel.: 3272097, 3275571  
Gram : HIRECT  
Telex : 031-62238 HIRT IN

**SECUNDERABAD**  
6-1-103 / 50  
Padmarao Nagar  
Secunderabad  
500 025  
Tel.: 066239