

Description

The SHLM324 consists of four independent, high gain internally frequency compensated operational amplifiers which are designed specifically to operated from a single power supply over a wide voltage rage. Operation from split power supplies is also possible. Application areas include transducer amplifier, DC gain blacks and all the conventional OP amp circuits which now can be easily implemented in single power suuply system.

Features

- *Large DC voltage gain: 100dB.
- *Wide operating supply range ($V_{cc}=3V\sim 32V$).
- *Input common-mode voltage includes ground.
- *Internal frequency compensated for unity gain.
- *Large output voltage swing: From 0V to $V_{cc}-1.5V$.
- *Power drain suitable for battery operation.

Package Dimensions

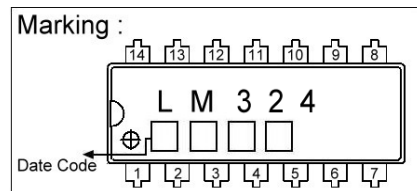
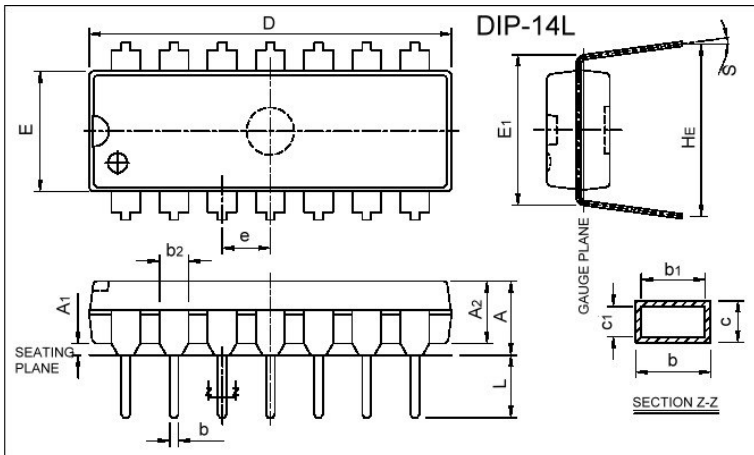

REF.	Millimeter		REF.	Millimeter	
	Min.	Max.		Min.	Max.
A	-	5.334	c1	0.203	0.279
A1	0.381	-	D	18.92	19.69
A2	3.175	3.429	E	6.096	6.604
b	0.406	0.508	E1	7.493	8.001
b1	0.356	0.508	e	2.413	2.667
b2	1.270	1.778	HE	8.509	9.525
c	0.203	0.356	L	3.175	3.683
			S	0'	15'

Pin Configuration

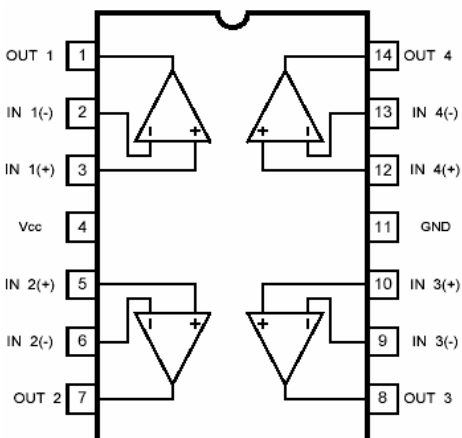

Block Diagram

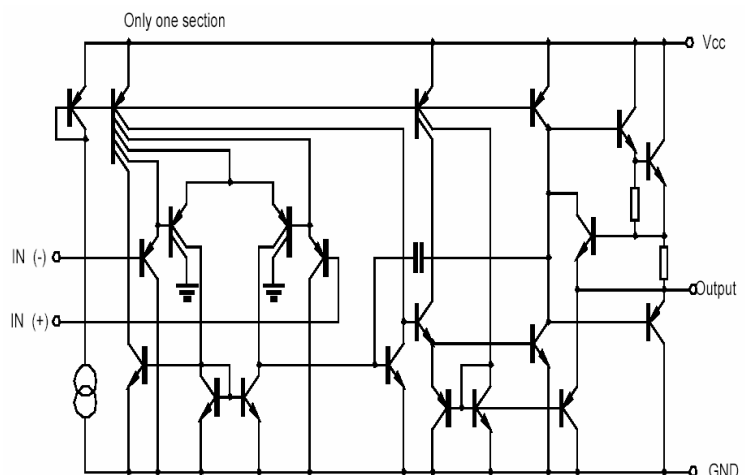

ABSOLUTE MAXIMUM RATINGS (Unless otherwise noted all is over operating free air temperature range)

Parameter	Symbol	Value	Units
Supply Voltage	V_{CC}	± 18	V
Differential Input Voltage	$V_{I(Diff)}$	32	V
Input Voltage	V_I	-0.3 ~ 32	V
Power Dissipation	P_D	570	mW
Operating, Storage Temperature	T_{OPR}, T_{STG}	0~70, -65~150	°C

ELECTRICAL CHARACTERISTICS ($V_{CC}=5V$, All voltage referenced to GND unless otherwise specified)

Parameter	Symbol	Test Conditions	Min	Typ	Max	Units
Input Offset Voltage	V_{IO}	$V_{CM}=0$ to $V_{CC}=-1.5V$, $V_{O(p)}=1.4V$, $R_S=0$			7	V
Input Offset Current	I_{IO}				50	nA
Input bias Current	I_b				250	nA
Input Common-Mode Voltage Range	$V_{I(R)}$	$V_{CC}=30V$	0	$V_{CC}-1.5$		V
Supply Current	I_{CC}	$R_L = \infty$ $V_{CC} = 30V$ $V_{CC} = 5V$		1.0 0.7	3.0 1.2	mA
Large Signal Voltage Gain	G_V	$V_{CC} = -15V$, $R_L > 2k\Omega$, $V_{O(p)} = 1$ to $11V$	25	100		V/mV
Output Voltage Swing	$V_{(OH)}$	$V_{CC} = 30V$, $R_L = 2k\Omega$	26			V
		$V_{CC} = 30V$, $R_L = 10k\Omega$	27			V
	$V_{(OL)}$	$V_{CC} = 5V$, $R_L > 10k\Omega$		5	20	mV
Common-Mode Rejection Ratio	CMRR		65	75		dB
Power Supply Rejection Ratio	PSRR		65	100		dB
Channel Separation	CS	$f = 1kHz$ to $20 kHz$		120		dB
Short Circuit to GND	I_{SC}			40	60	mA
Output Current	I_{Source}	$V_I(+)=1V$, $V_I(-)=0V$, $V_{CC}=15V$, $V_{O(p)}=2V$	20	40		mA
		$V_I(+)=0V$, $V_I(-)=1V$, $V_{CC}=15V$, $V_{O(p)}=2V$	10	13		mA
	I_{Sink}	$V_I(+)=1V$, $V_I(-)=0V$, $V_{CC}=15V$, $V_{O(p)}=200mV$	12	45		μA
Differential Input Voltage	$V_{I(Diff)}$				V_{CC}	V

Typical performance Characteristics

