

**Features**

- Colorless transparency lens type
- $\phi 5\text{mm}$ (T-13/4) all plastic mold type
- Low power consumption
- High power, High speed type

**Applications**

- Infrared remote control and free air transmission systems with low forward voltage and comfortable radiation angle requirements in combination with PIN photodiodes or phototransistors.

**Outline Dimensions**

**unit : mm**

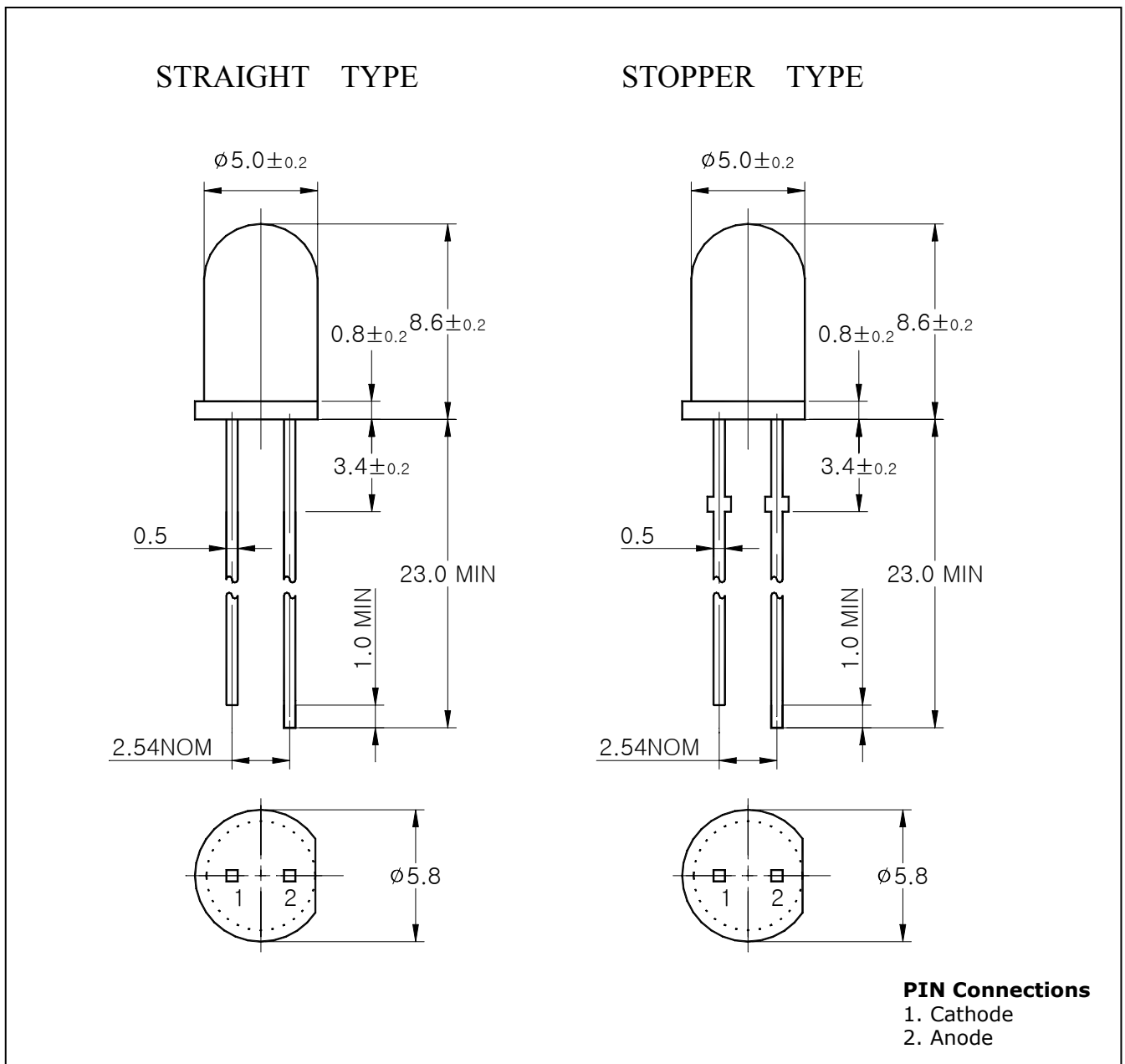

**Absolute maximum ratings**

Characteristic	Symbol	Ratings	Unit
Power Dissipation	$P_D$	150	mW
Forward Current	$I_F$	100	mA
*1Peak Forward Current	$I_{FP}$	1	A
Reverse Voltage	$V_R$	4	V
Operating Temperature	$T_{opr}$	-25 ~ 85	°C
Storage Temperature	$T_{stg}$	-30 ~ 100	°C
*2Soldering Temperature	$T_{sol}$	260°C for 5 seconds	

\*1.Duty ratio = 1/16, Pulse width = 0.1ms

\*2.Keep the distance more than 2.0mm from PCB to the bottom of IRED package

**Electrical Characteristics**

Characteristic	Symbol	Test Condition	Min.	Typ.	Max.	Unit
Forward Voltage	$V_F$	$I_F= 50\text{mA}$	-	1.5	2.0	V
Radiant Intensity	$I_E$	$I_F= 50\text{mA}$	30	70	-	mW/Sr
Peak Wavelength	$\lambda_p$	$I_F= 50\text{mA}$	-	875	-	nm
Spectrum Bandwidth	$\Delta \lambda$	$I_F= 50\text{mA}$	-	45	-	nm
Rise Time	$t_r$	$I_F= 50\text{mA}$	-	15	-	ns
Reverse Current	$I_R$	$V_R=4\text{V}$	-	-	10	uA
*3Half angle	$\theta^{1/2}$	$I_F= 50\text{mA}$	-	$\pm 20$	-	deg

\*3.  $\theta^{1/2}$  is the off-axis angle where the luminous intensity is 1/2 the peak intensity

Characteristic Diagrams

Fig. 1  $I_F - V_F$

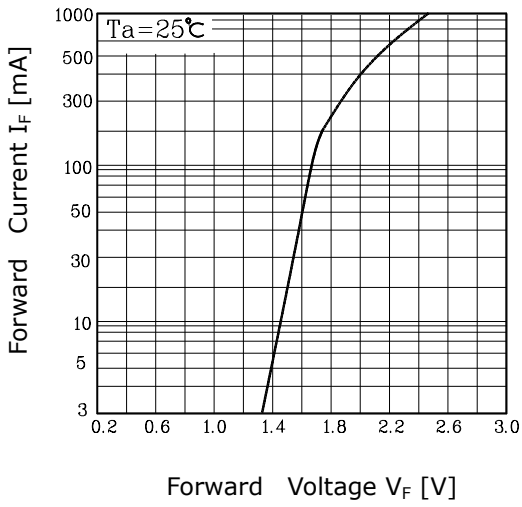

Fig. 2  $I_E - I_F$

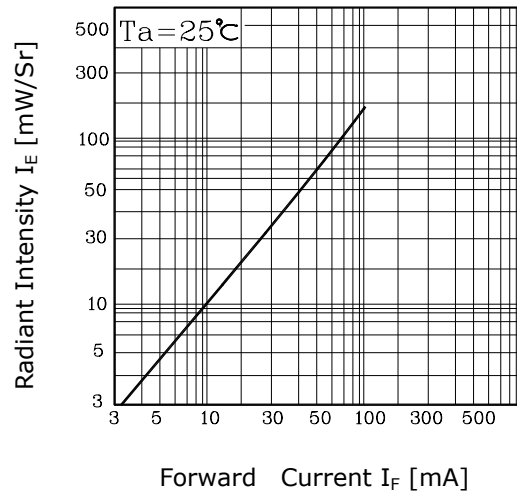

Fig. 3  $I_F - T_a$

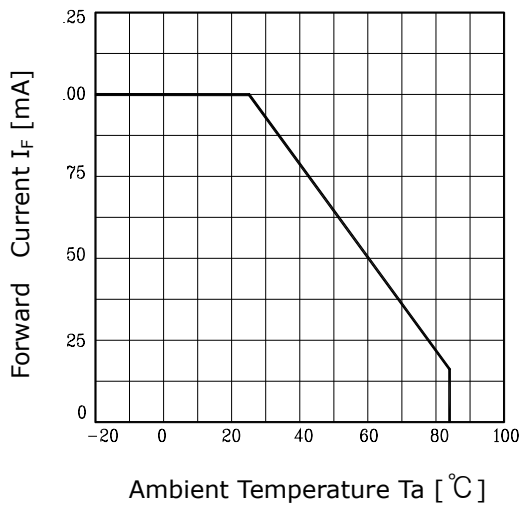

Fig. 4 Spectrum Distribution

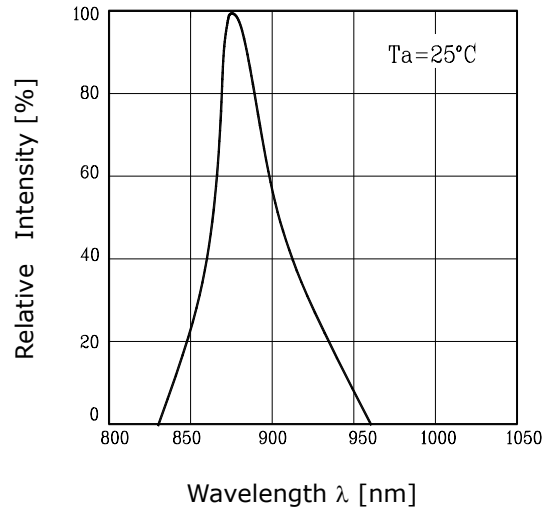

Fig. 5 Radiation Diagram

