

Main Product Characteristics

$I_{F(AV)}$	6A, $T_c=99^\circ\text{C}$
V_{RRM}	600V
T_J	175°C
$V_{F(TYP)}@25^\circ\text{C}$	1.45V

■ Features

- Low Conduction and Switching Loss
- Positive Temperature Coefficient on V_F
- Temperature Independent Switching Behavior
- Fast Reverse Recovery
- High Surge Current Capability
- Pb-free lead plating

■ Benefits

- Higher System Efficiency
- Parallel Device Convenience
- High Temperature Application
- High Frequency Operation
- Hard Switching & High Reliability
- Environmental Protection

■ Maximum ratings and electrical characteristics

Parameter	Conditions	Symbol	SIC06C60			UNIT
Peak Repetitive Reverse Voltage	$T_J=25^\circ\text{C}$	V_{RRM}	600			V
Peak Reverse Surge Voltage	$T_J=25^\circ\text{C}$	V_{RSM}	600			
DC Blocking Voltage	$T_J=25^\circ\text{C}$	V_R	600			
Continuous Forward Current	$T_c=25^\circ\text{C}$	I_F	9			A
	$T_c=99^\circ\text{C}$		6			
	$T_c=135^\circ\text{C}$		4			
Non-Repetitive Peak Forward surge current	$T_c=25^\circ\text{C}, T_p=10\text{ms}, \text{Half Sine-Wave}$	I_{FSM}	51			A
	$T_c=125^\circ\text{C}, T_p=10\text{ms}, \text{Half Sine-Wave}$		45			
	$T_c=25^\circ\text{C}, T_p=10\mu\text{s}, \text{Pulse}$		339			
Repetitive Peak Forward surge current	$T_c=25^\circ\text{C}, T_p=10\text{ms}, \text{Half Sine-Wave}, D=0.1$	I_{FRM}	41			A
	$T_c=125^\circ\text{C}, T_p=10\text{ms}, \text{Half Sine-Wave}, D=0.1$		35			
Power Dissipation	$T_c=25^\circ\text{C}$	P_D	22			W
	$T_c=125^\circ\text{C}$		7.4			
Operation Junction and Storage Temperature		T_J	175			°C
		T_{stg}	-55 to 175			
Thermal Resistance Junction to Case		$R_{\theta JC}$	6.8			°C/W
Parameter	Conditions	Symbol	MIN.	TYP.	MAX.	UNIT
DC Blocking Voltage	$I_R=100\mu\text{A}, T_J=25^\circ\text{C}$	V_{DC}		>650		V
Forward Voltage	$I_F=6\text{A}, T_J=25^\circ\text{C}$	V_F		1.45	1.8	V
	$I_F=6\text{A}, T_J=175^\circ\text{C}$			1.8	2.2	
Reverse Current	$V_R=600\text{V}, T_J=25^\circ\text{C}$	I_R		<1	30	uA
	$V_R=600\text{V}, T_J=175^\circ\text{C}$			10	160	
Total Capacitive Charge	$I_F=6\text{A}, dI/dt=300\text{A}/\mu\text{s}, V_R=400\text{V}, T_J=25^\circ\text{C}$	Q_C		13		nC
Total Capacitive	$V_R=1\text{V}, T_J=25^\circ\text{C}, f=1\text{MHz}$	C		244		pF
	$V_R=200\text{V}, T_J=25^\circ\text{C}, f=1\text{MHz}$			37		
	$V_R=400\text{V}, T_J=25^\circ\text{C}, f=1\text{MHz}$			36		

■ Outline



Package ITO-220AC

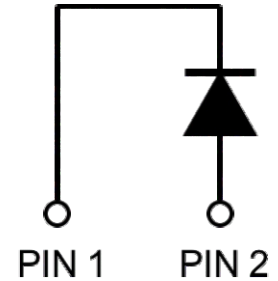

Inner Circuit

■ Applications

- SMPS
- PFC
- Solar/Wind Renewable Energy
- Power Inverters
- Motor Drives

Rating and characteristic curves

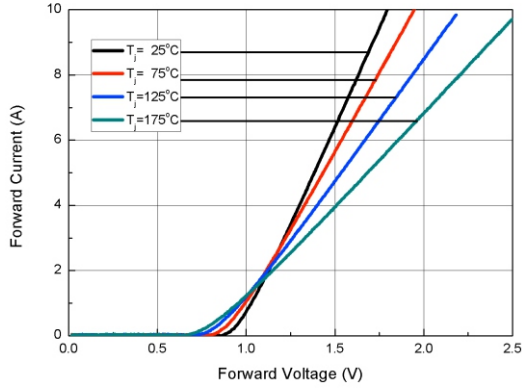

Fig. 1 Forward Characteristics

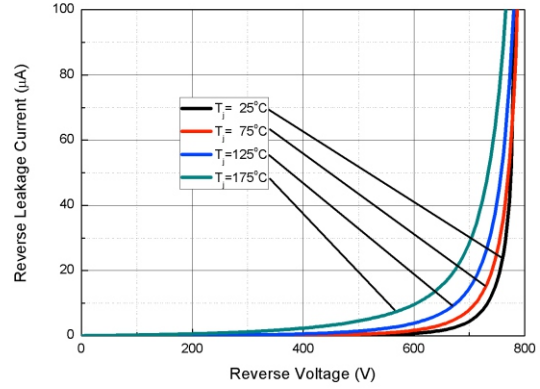

Fig. 2 Reverse Characteristics

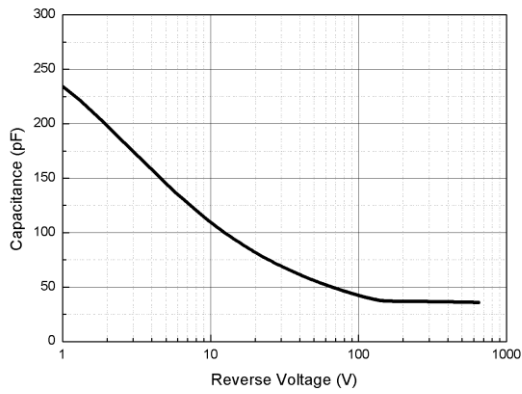

Fig. 3 Capacitance vs. Reverse Voltage

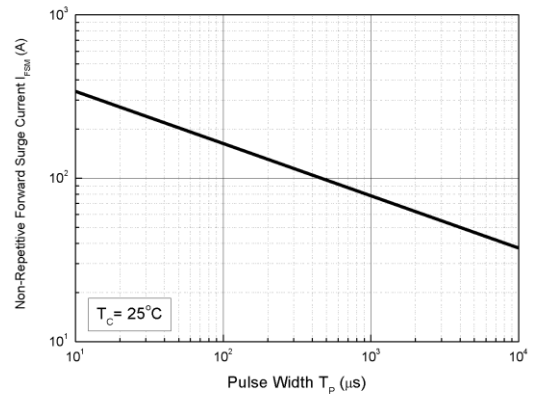

Fig. 4 Non-Repetitive Peak Forward Surge Current (Pulse Mode)

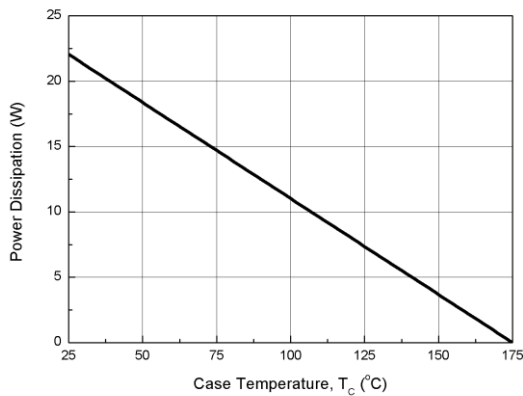

Fig. 5 Power Derating

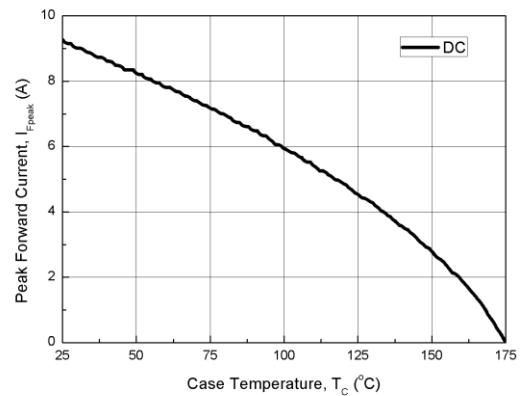
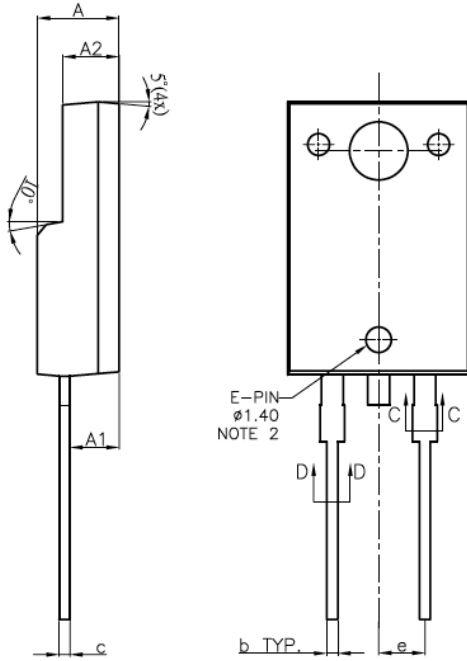
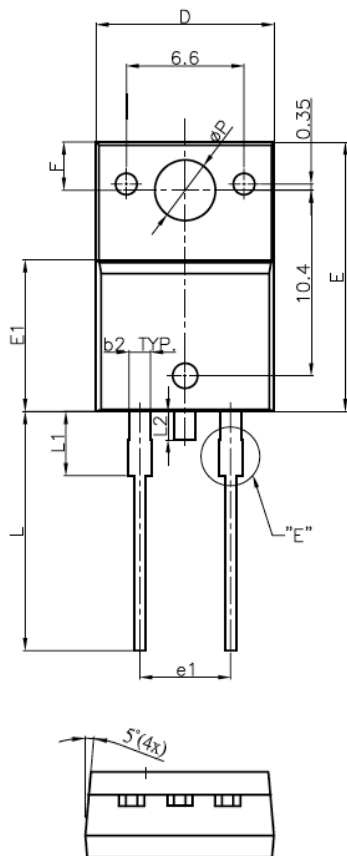

Fig. 6 Current Derating

■ Outline



SYMBOLS	DIMENSIONS IN MILLIMETERS			DIMENSIONS IN INCHES		
	MIN.	NOM.	MAX.	MIN.	NOM.	MAX.
A	4.20	4.50	4.80	0.165	0.177	0.189
A1	2.50	---	2.90	0.098	---	0.114
A2	2.90	3.10	3.30	0.114	0.122	0.130
b	0.30	---	0.93	0.012	---	0.037
b1	0.30	0.60	0.90	0.012	0.024	0.035
b2	1.00	---	1.43	0.039	---	0.056
b3	1.00	1.20	1.40	0.039	0.047	0.055
c	0.50	---	0.73	0.020	---	0.029
c1	0.50	0.60	0.70	0.020	0.024	0.028
D	9.90	10.00	10.10	0.390	0.394	0.398
E	14.80	15.10	15.40	0.583	0.594	0.606
E1	8.40	8.50	8.60	0.331	0.335	0.339
e	---	2.55 BSC	---	---	0.100 BSC	---
e1	---	5.10 BSC	---	---	0.200 BSC	---
F	2.55	2.70	2.85	0.100	0.106	0.112
G	0.00	---	0.127	0.000	---	0.005
L	13.00	13.40	13.80	0.512	0.528	0.543
L1	3.45	3.60	3.75	0.136	0.142	0.148
L2	---	---	1.60	---	---	0.063
φP	2.90	3.20	3.50	0.114	0.126	0.138



NOTES:

1. All dimension are in mm[inch].
2. Tolerance : ±0.004inch.

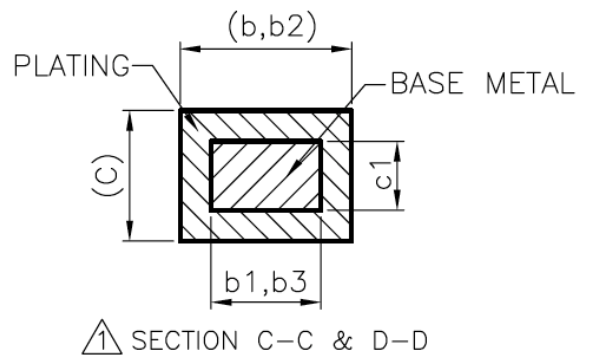
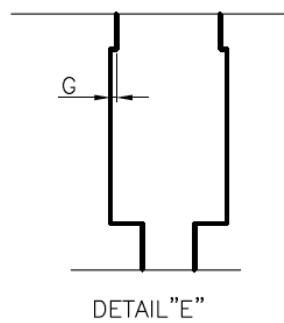

■ Marking information

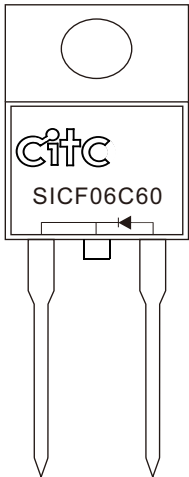

SICF06C60 : Product type marking code

 : CITC Logo

■ Ordering/Packing information

	Part number	Case	Q'TY/Tube (PCS)	Q'TY Box(PCS)	Q'TY/Carton(PCS)
Halogen Free	SICF06C60	ITO-220AC	50	4,000	8,000

Notes : 1. For packaging details, please reference our website at <http://www.citcorp.com.tw/tchinese/products/index.php>

- CITC reserves the right to make changes to this document and its products and specifications at any time without notice.
- Customers should obtain and confirm the latest product information and specifications before final design, purchase or use.
- CITC makes no warranty, representation or guarantee regarding the suitability of its products for any particular purpose, nor does CITC assume any liability for application assistance or customer product design.
- CITC does not warrant or accept any liability with products which are purchased or used for any unintended or unauthorized application.
- No license is granted by implication or otherwise under any intellectual property rights of CITC.
- CITC products are not authorized for use as critical components in life support devices or systems without express written approval of CITC.