



SiI9233A HDMI Receiver with Repeater, Multi-channel Audio, and Deep Color

Data Brief

Document # SiI-DB-1061-A07

August 2010

Copyright Notice

Copyright © 2009-2010 Silicon Image, Inc. All rights reserved. These materials contain proprietary and confidential information (including trade secrets, copyright and other interests) of Silicon Image, Inc. You may not use these materials except only for your bona fide non-commercial evaluation of your potential purchase of products and/or services from Silicon Image or its affiliates, and/or only in connection with your purchase of products and/or services from Silicon Image or its affiliates, and only in accordance with the terms and conditions herein. You have no right to copy, modify, transfer, sublicense, publicly display, create derivative works of or distribute these materials, or otherwise make these materials available, in whole or in part, to any third party.

Trademark Acknowledgment

Silicon Image™, VastLane™, SteelVine™, PinnaClear™, Simplay™, Simplay HD™, Satalink™, InstaPort™, and TMDS™ are trademarks or registered trademarks of Silicon Image, Inc. in the United States and other countries. HDMI®, the HDMI logo and High-Definition Multimedia Interface™ are trademarks or registered trademarks of, and are used under license from, HDMI Licensing, LLC. x.v.Color™ is a trademark of Sony Corporation.

Export Controlled Document

This document contains information subject to the Export Administration Regulations (EAR) and has a classification of EAR99 or is controlled for Anti-Terrorism (AT) purposes. Transfer of this information by any means to an EAR Country Group E:1 or foreign national thereof (whether in the U.S. or abroad) may require an export license or other approval from the U.S. Department of Commerce. For more information, contact the Silicon Image Director of Global Trade Compliance.

Further Information

To request other materials, detailed hardware and software guides, and additional information, contact your local Silicon Image, Inc. sales office or visit the Silicon Image, Inc. web site at www.siliconimage.com. Information about obtaining licenses required for using HDMI and HDCP technologies is available from www.hdmi.org and www.digital-cp.com.

© 2009-2010 Silicon Image, Inc. All rights reserved.

Introduction

The SiI9233A HDMI Receiver with Repeater, Multi-channel Audio, and Deep Color is a 4-port HDMI® receiver. AV receivers that connect to DTVs displaying 10/12-bit color depth can now provide the highest quality protected digital audio and video, including common 3D formats up to 12-bit, 1080p at 24 Hz resolution. The receiver supports Deep Color video up to 12-bit, 1080p at 60 Hz. Efficient color space conversion receives RGB or YCbCr video data and sends either standard-definition or high-definition RGB or YCbCr formats.

The SiI9233A receiver supports the extended gamut YCC or xvYCC color space, described in the IEC 61966-2-4 specification, that supports approximately 1.8 times the number of colors as the RGB color space. The xvYCC color space also makes full use of the range on the standard 8-bit resolution per pixel.

The SiI9233A receiver is pre-programmed with High-bandwidth Digital Content Protection (HDCP) keys; this helps reduce programming overhead and lowers manufacturing costs.

An integrated Extended Display Identification Data (EDID) block stored in non-volatile memory (NVM) can be programmed at the time of manufacture using the local I²C bus. On-board RAM can also be loaded with EDID data from the system microcontroller during initialization if the NVM is not used. The EDID is reflected on the four HDMI ports through the DDC bus. Flexibility allows mixing different EDID formats in an application. This feature can eliminate up to four EDID ROMs while also saving board space.

Flexible power management provides extremely low standby power consumption; standby power can be supplied from an HDMI 5 V signal or from a separate standby power pin. If the NVM stores the EDID, only the 5 V power from the source device is needed to read the EDID.

Inputs

- Four HDMI/DVI-compatible ports
- TMDS™ core runs at 25–225 MHz

Digital Video Output

- xvYCC to extended RGB
- 36-bit RGB/YCbCr 4:4:4
- 16/20/24-bit YCbCr 4:2:2
- 8/10/12-bit YCbCr 4:2:2 (ITU BT.656)
- True 12-bit accurate output data using an internal 14-bit wide processing path
- Programmable drive strength from 2 mA to 14 mA

Digital Audio Interface

- DTS-HD and Dolby TrueHD high bit rate audio
- I²S output with 4 data signals for multi-channel formats and flexible, programmable channel mapping
- S/PDIF output supports PCM, Dolby Digital, DTS digital audio transmission with a 32–192 kHz F_s sample rate
- Intelligent audio mute capability avoids pops and noise with automatic soft mute and unmute
- IEC60958 or IEC61937 compatible

Control

- Consumer Electronics Control (CEC) interface incorporates an HDMI CEC I/O and an integrated CEC Programming Interface (CPI)
- Automatic Feature Abort response for unsupported commands and automatic message retry on transmit

Package

- 20 mm x 20 mm 144-pin TQFP package with ePad™

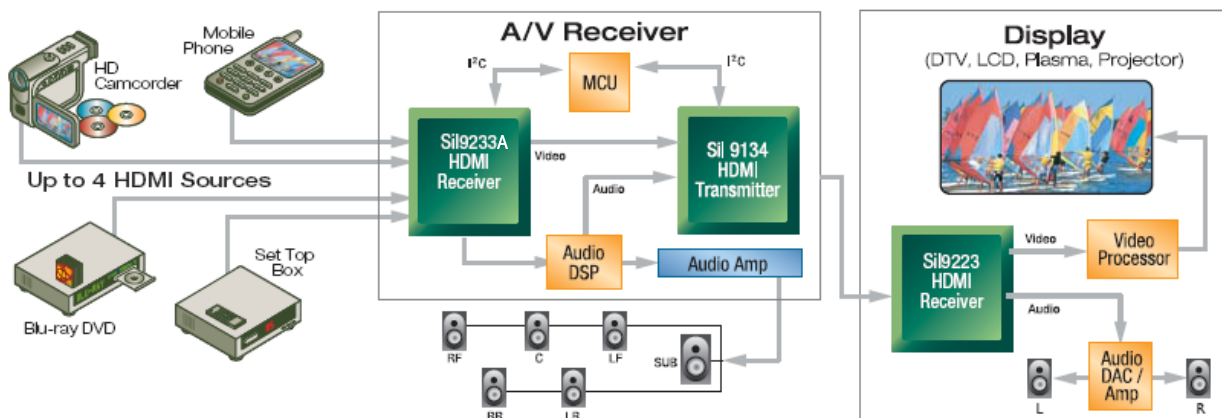

Figure 1. Typical Application

System Applications

The SiI9233A receiver is designed for digital televisions that require support for HDMI Deep Color. The device allows receipt of 10/12-bit color depth up to 1080p resolutions. A single receiver provides four HDMI input ports. The video output interfaces to a video processor and the audio output can interface directly to an audio DAC or an audio DSP for further processing as shown in [Figure 1](#).

Comparing the SiI9233A Receiver with SiI9127A, SiI9223A, SiI9125, and SiI9135A Receivers

[Table 1](#) summarizes the functional differences among the SiI9127A, SiI9125, SiI9135A, SiI9223A, and SiI9233A receivers.

Table 1. Comparison Among Silicon Image Receivers

Feature	SiI9125	SiI9127A	SiI9135A	SiI9223A	SiI9233A
HDMI Input Connections					
TMDS Input Ports	2	2	2	4	4
Color Depth	8/10/12-bit	8/10/12-bit	8/10/12-bit	8/10/12-bit	8/10/12-bit
DDC Input Ports	2	2	2	4	4
Maximum TMDS Input Clock	225 MHz	225 MHz	225 MHz	225 MHz	225 MHz
Video Output					
Digital Video Output Ports	1	1	1	1	1
Maximum Output Pixel Clock	165 MHz.	165 MHz.	165 MHz.	165 MHz.	165 MHz.
Maximum Output Bus Width	36	36	36	36	36
Audio Formats					
S/PDIF Output Ports	1	1	1	1	1
I ² S Output	2 channel	2 channel	8 channel	2 channel	8 channel
DSD Output	2 channel	NA	6 channel	NA	8 channel
High Bit Rate Audio Support Compressed DTS-HD and Dolby True-HD	No	No	Yes	No	Yes
Maximum Audio Sample Rate (Fs)	192 kHz	192 kHz	192 kHz	192 kHz	192 kHz
Video Processing					
Color Space Converter	RGB to/from YCbCr	RGB to/from YCbCr xvYCC to RGB	RGB to/from YCbCr	RGB to/from YCbCr xvYCC to RGB	RGB to/from YCbCr xvYCC to RGB
Pixel Clock Divider	÷ 4, ÷ 2	÷ 4, ÷ 2	÷ 4, ÷ 2	÷ 4, ÷ 2	÷ 4, ÷ 2
Digital Video Bus Mapping	swap Cb, Cr pins	swap Cb, Cr pins	swap Cb, Cr pins	swap Cb, Cr pins	swap Cb, Cr pins
Other Features					
3D Support	No	No	No	Yes	Yes
CEC	No	Yes	No	Yes	Yes
EDID	No	NVRAM	No	NVRAM	NVRAM
HDCP Repeater Support	No	No	Yes	No	Yes
Interlaced Format Detection Pin	Yes	Yes	Yes	Yes	Yes
Package	144-pin TQFP ePad	128-pin TQFP ePad	144-pin TQFP ePad	144-pin TQFP ePad	144-pin TQFP ePad

Pin Diagram

Figure 2 shows the pin assignments of the SiI9233A receiver. Pin names are generalized by type for this document. The list below the diagram describes the purpose of each type. The package is 20 mm x 20 mm 144-pin TQFP package with ePad™.

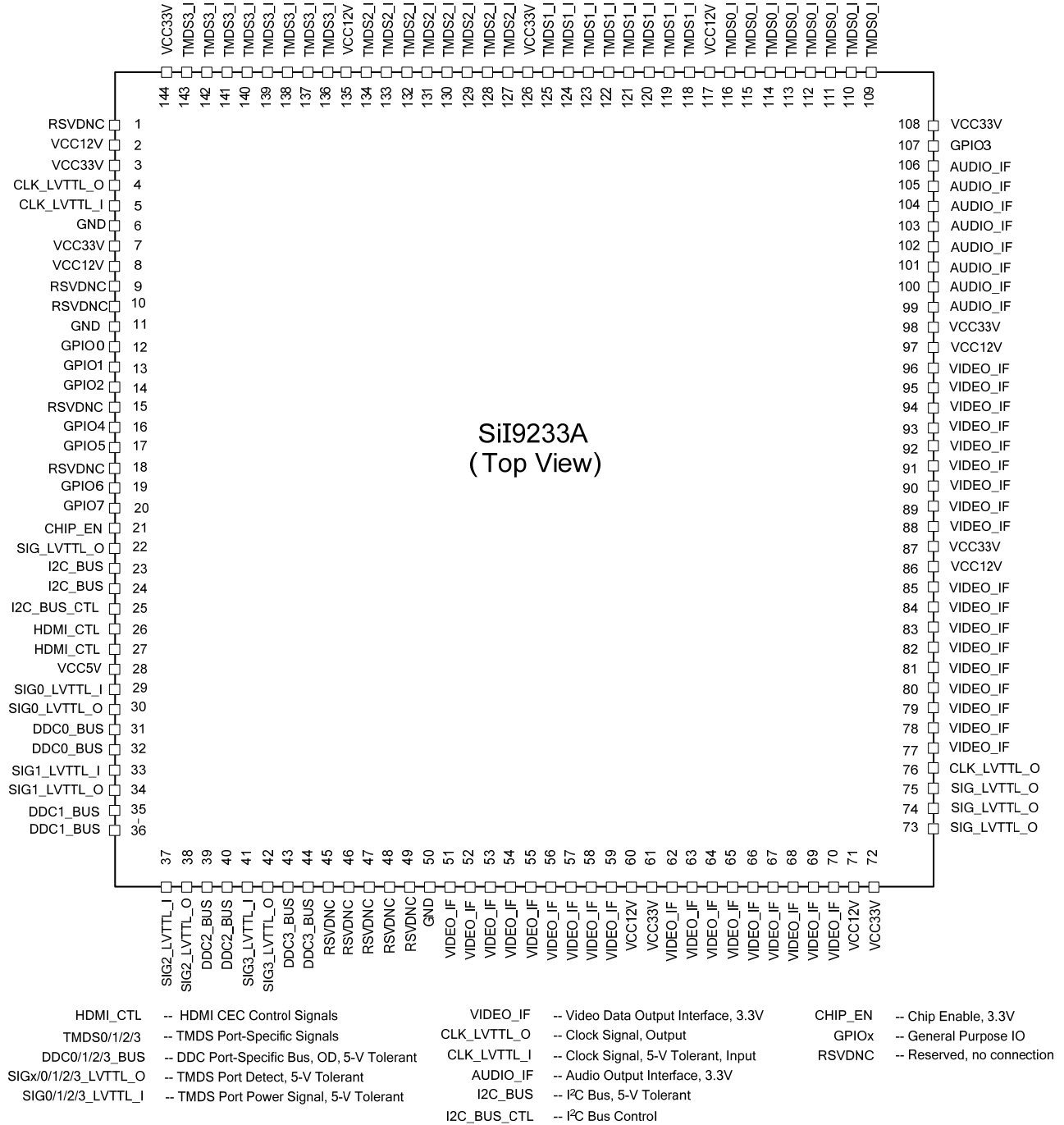

Figure 2. Pin Diagram

Package Information

ePad Requirements

The SiI9233A receiver is packaged in a 144-pin, 20 mm x 20 mm TQFP package with an ExposedPad™ (ePad™) that is used for the electrical ground of the device and for improved thermal transfer characteristics. The ePad dimensions are 4.445 mm x 4.0604 mm ±0.15 mm. Soldering the ePad to the ground plane of the PCB is **required** to meet package power dissipation requirements at full speed operation, and to correctly connect the chip circuitry to electrical ground. A clearance of at least 0.25 mm should be designed on the PCB between the edge of the ePad and the inner edges of the lead pads to avoid the possibility of electrical shorts.

The thermal land area on the PCB may use thermal vias to improve heat removal from the package. These thermal vias also double as the ground connections of the chip and must attach internally in the PCB to the ground plane. An array of vias should be designed into the PCB beneath the package. For optimum thermal performance, the via diameter should be 12 mils to 13 mils (0.30 mm to 0.33 mm) and the via barrel should be plated with 1-ounce copper to plug the via. This design helps to avoid any solder wicking inside the via during the soldering process, which may result in voids in solder between the pad and the thermal land. If the copper plating does not plug the vias, the thermal vias can be tented with solder mask on the top surface of the PCB to avoid solder wicking inside the via during assembly. The solder mask diameter should be at least 4 mils (0.1 mm) larger than the via diameter.

Package stand-off when mounting the device also needs to be considered. For a nominal stand-off of approximately 0.1 mm the stencil thickness of 5 mils to 8 mils should provide a good solder joint between the ePad and the thermal land.

[Figure 3](#) on the next page shows the package dimensions of the SiI9233A receiver.

CB Layout Guidelines

Refer to Silicon Image document *PCB Layout Guidelines: Designing with Exposed Pads* for basic PCB design guidelines when designing with thermally enhanced packages using the exposed pad. This application note is intended for use by PCB layout designers.

Package Dimensions

These drawings are not to scale.

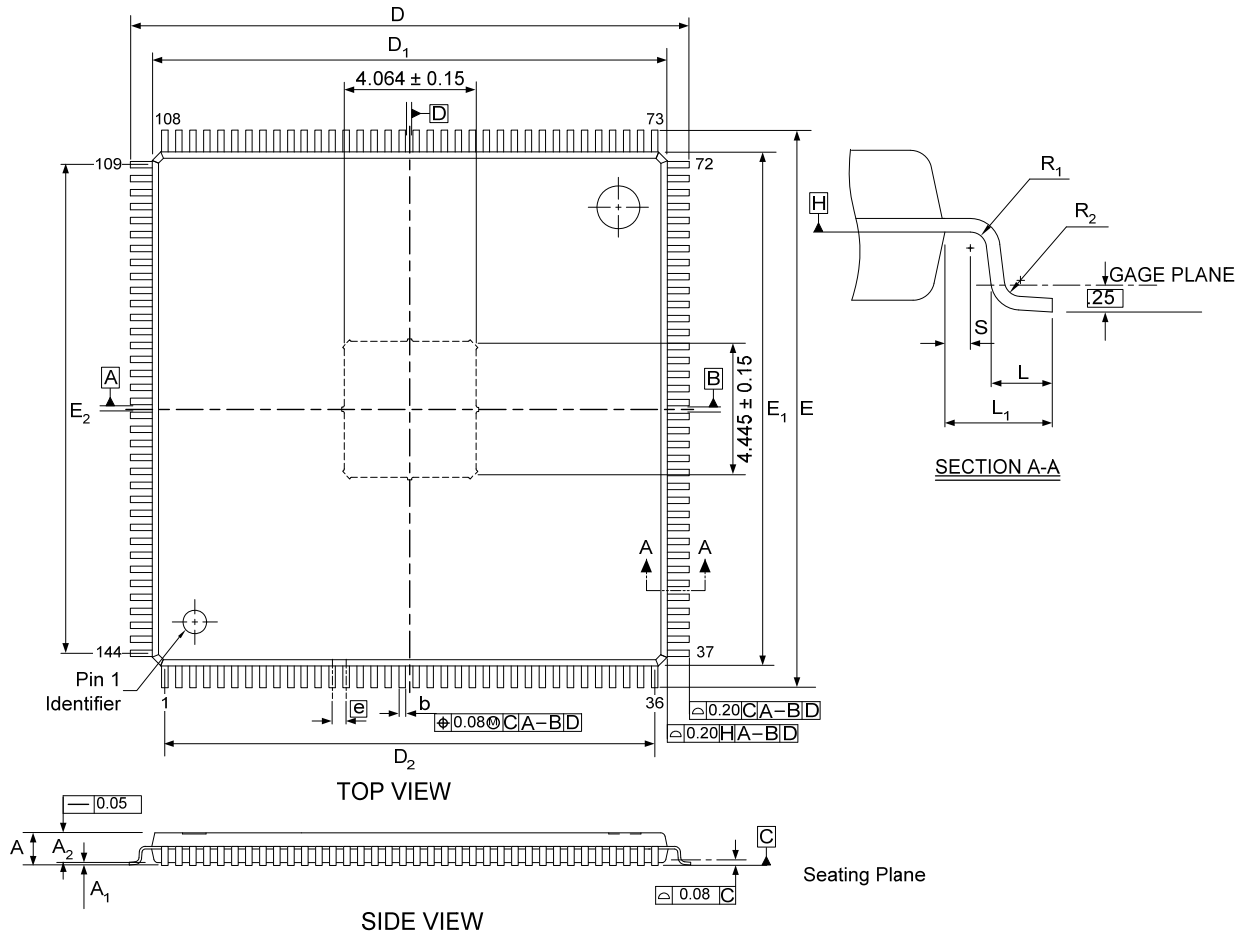

JEDEC Package Code MS-026-AFB

Item	Description	Min	Typ	Max
A	Thickness	1.00	1.10	1.20
A1	Stand-off	0.05	0.10	0.15
A2	Body thickness	0.95	1.00	1.05
D	Footprint	22.00 BSC		
E	Footprint	22.00 BSC		
D1	Body size	20.00 BSC		
E1	Body size	20.00 BSC		
D2	Lead Row Width	17.5 BSC		
E2	Lead Row Width	17.5 BSC		

Item	Description	Min	Typ	Max
b	Lead width	0.17	0.22	0.27
C	Lead thickness	0.09	—	0.20
e	Lead pitch	0.50 BSC		
L	Lead foot length	0.45	0.60	0.75
L1	Total lead length	1.00 REF		
R1	Lead radius, inside	0.08	—	—
R2	Lead radius, outside	0.08	—	0.20
S	Lead horizontal run	0.20	—	—

Dimensions in millimeters.

Overall thickness A = A1 + A2.

Figure 3. 144-Pin TQFP Package Diagram

Marking Specification

Figure 4 shows the markings of the SiI9233A package. Refer to specifics in Figure 3 on page 5.

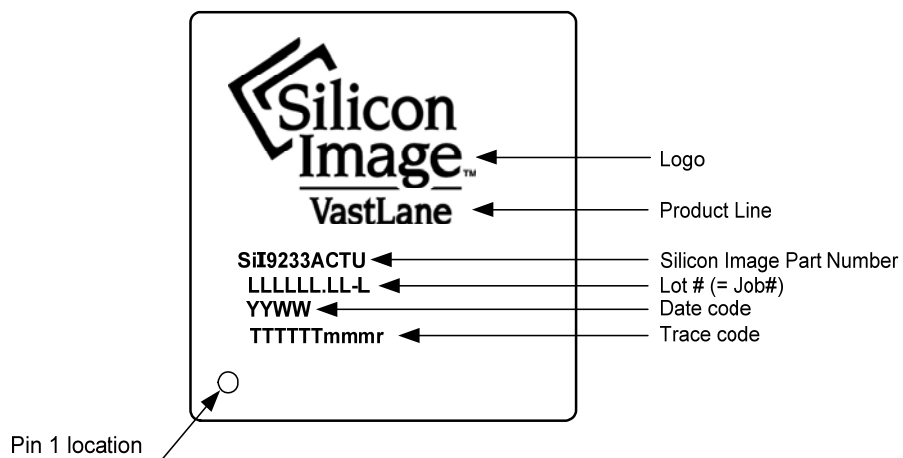

Figure 4. Marking Diagram

Ordering Information

Production Part Numbers:

TMDS Input Clock Range	Part Number
25–225 MHz	SiI9233ACTU

The universal package may be used in lead-free and ordinary process lines.

Disclaimers

These materials are provided on an “AS IS” basis. Silicon Image, Inc. and its affiliates disclaim all representations and warranties (express, implied, statutory or otherwise), including but not limited to: (i) all implied warranties of merchantability, fitness for a particular purpose, and/or non-infringement of third party rights; (ii) all warranties arising out of course-of-dealing, usage, and/or trade; and (iii) all warranties that the information or results provided in, or that may be obtained from use of, the materials are accurate, reliable, complete, up-to-date, or produce specific outcomes. Silicon Image, Inc. and its affiliates assume no liability or responsibility for any errors or omissions in these materials, makes no commitment or warranty to correct any such errors or omissions or update or keep current the information contained in these materials, and expressly disclaims all direct, indirect, special, incidental, consequential, reliance and punitive damages, including WITHOUT LIMITATION any loss of profits arising out of your access to, use or interpretation of, or actions taken or not taken based on the content of these materials.

Silicon Image, Inc. and its affiliates reserve the right, without notice, to periodically modify the information in these materials, and to add to, delete, and/or change any of this information.

Notwithstanding the foregoing, these materials shall not, in the absence of authorization under U.S. and local law and regulations, as required, be used by or exported or re-exported to (i) any U.S. sanctioned or embargoed country, or to nationals or residents of such countries; or (ii) any person, entity, organization or other party identified on the U.S. Department of Commerce's Denied Persons or Entity List, the U.S. Department of Treasury's Specially Designated Nationals or Blocked Persons List, or the Department of State's Debarred Parties List, as published and revised from time to time; (iii) any party engaged in nuclear, chemical/biological weapons or missile proliferation activities; or (iv) any party for use in the design, development, or production of rocket systems or unmanned air vehicles.

Products and Services

The products and services described in these materials, and any other information, services, designs, know-how and/or products provided by Silicon Image, Inc. and/or its affiliates are provided on as “AS IS” basis, except to the extent that Silicon Image, Inc. and/or its affiliates provides an applicable written limited warranty in its standard form license agreements, standard Terms and Conditions of Sale and Service or its other applicable standard form agreements, in which case such limited warranty shall apply and shall govern in lieu of all other warranties (express, statutory, or implied). EXCEPT FOR SUCH LIMITED WARRANTY, SILICON IMAGE, INC. AND ITS AFFILIATES DISCLAIM ALL REPRESENTATIONS AND WARRANTIES (EXPRESS, IMPLIED, STATUTORY OR OTHERWISE), REGARDING THE INFORMATION, SERVICES, DESIGNS, KNOW-HOW AND PRODUCTS PROVIDED BY SILICON IMAGE, INC. AND/OR ITS AFFILIATES, INCLUDING BUT NOT LIMITED TO, ALL IMPLIED WARRANTIES OF MERCHANTABILITY, FITNESS FOR A PARTICULAR PURPOSE, AND/OR NON-INFRINGEMENT OF THIRD PARTY RIGHTS. YOU ACKNOWLEDGE AND AGREE THAT SUCH INFORMATION, SERVICES, DESIGNS, KNOW-HOW AND PRODUCTS HAVE NOT BEEN DESIGNED, TESTED, OR MANUFACTURED FOR USE OR RESALE IN SYSTEMS WHERE THE FAILURE, MALFUNCTION, OR ANY INACCURACY OF THESE ITEMS CARRIES A RISK OF DEATH OR SERIOUS BODILY INJURY, INCLUDING, BUT NOT LIMITED TO, USE IN NUCLEAR FACILITIES, AIRCRAFT NAVIGATION OR COMMUNICATION, EMERGENCY SYSTEMS, OR OTHER SYSTEMS WITH A SIMILAR DEGREE OF POTENTIAL HAZARD. NO PERSON IS AUTHORIZED TO MAKE ANY OTHER WARRANTY OR REPRESENTATION CONCERNING THE PERFORMANCE OF THE INFORMATION, PRODUCTS, KNOW-HOW, DESIGNS OR SERVICES OTHER THAN AS PROVIDED IN THESE TERMS AND CONDITIONS.



1060 E. Arques Avenue
Sunnyvale, CA 94085
T 408.616.4000 F 408.830.9530
www.siliconimage.com