

## FEATURES

- Compatible with EIA-422 and TIA/EIA-485-A standard
- 2.5V~5.5V  $V_{CC1}$ , 4.5V~5.5V  $V_{CC2}$  power supply range, full-duplex
- Bus port ESD protection capacity of over 15kV HBM
- 1/8 unit load, allow up to 256 transceivers on the bus
- Driver Short-circuit protection, receiver open-circuit failure protection
- Low power shutdown function
- Data transmission up to 16Mbps in an electric noise environment
- Wide temperature range:  $-40^{\circ}\text{C}\sim 125^{\circ}\text{C}$
- Strong anti-noise ability
- High CMTI:  $\pm 100\text{kV}/\mu\text{s}$  (typical value)
- Up to 5000 VRMS isolation voltage resistance
- Isolation gate life:  $>40$  years.
- Wide-body SOIC16 package, RoHS compliant

## PRODUCT APPEARANCE



Provide green and environmentally friendly lead-free package

## DESCRIPTION

The SIT3491ISO is a capacitive isolated full duplex RS-422/485 transceiver, and bus port ESD protection capacity of more than 15kV HBM. It is a RS-422/485 transceiver fully meet the requirements of TIA/EIA-422/485 standard.

The SIT3491ISO includes a driver and a receiver, both of which can be enabled and closed independently. When both are disabled, both the driver and the receiver output are high resistance state. SIT3491ISO has 1/8 load, which allows 256 SIT3491ISO transceivers to be connected to the same communication bus. It can realize error-free data transmission up to 16Mbps.

The SIT3491ISO has the functions of fail-safe, current-limiting protection, over-voltage protection, etc.

**FUNCTIONAL SCHEMATIC BLOCK DIAGRAM**

**PIN CONFIGURATION**

Fig 1 SIT3491ISO pin configuration

**PIN DESCRIPTION**

PIN	SYMBOL	DESCRIPTION
1	V <sub>CC1</sub>	Power supply, V <sub>CC1</sub>
2	GND1	Ground point of power supply V <sub>CC1</sub>
3	R	Receiver Output. When /RE is low and if A - B ≥ -10mV, R will be high; if A - B ≤ -200mV, R will be low.

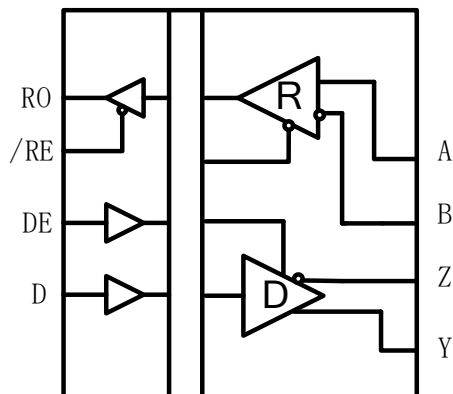
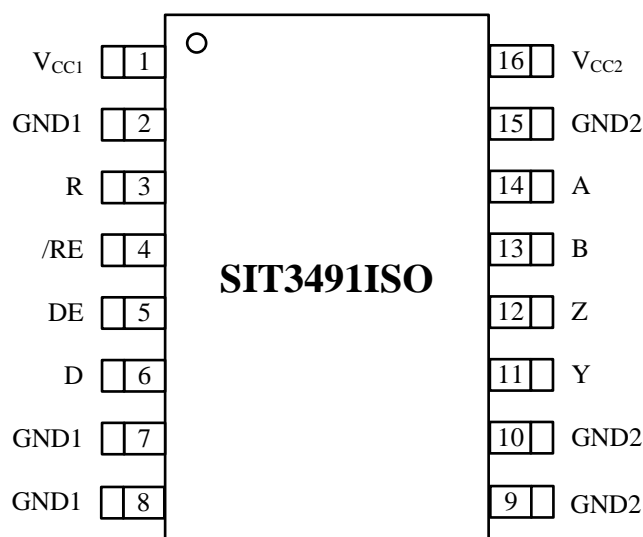
PIN	SYMBOL	DESCRIPTION
4	/RE	Receiver Output Enable. Drive /RE low to enable RO; RO is high impedance when /RE is high. Drive /RE high and DE low to enter low-power shutdown mode.
5	DE	Driver Output Enable. Drive DE high to enable driver outputs. These outputs are high impedance when DE is low. Drive /RE high and DE low to enter low-power shutdown mode.
6	D	Driver Input. With DE high, a low on D forces non-inverting output low and inverting output high. Similarly, a high on D forces non-inverting output high and inverting output low.
7	GND1	Ground point of power supply $V_{CC1}$ .
8	GND1	Ground point of power supply $V_{CC1}$ .
9	GND2	Ground point of power supply $V_{CC2}$ .
10	GND2	Ground point of power supply $V_{CC2}$ .
11	Y	Non-inverting driver output
12	Z	Inverting driver output
13	B	Inverting receiver input
14	A	Non-inverting receiver input
15	GND2	Ground point of power supply $V_{CC2}$ .
16	$V_{CC2}$	Power supply, $V_{CC2}$ .

## LIMITING VALUES

PARAMETER	SYMBOL	VALUE	UNIT
Supply voltage	$V_{CC1}, V_{CC2}$	-0.5~+6	V
control port voltage	/RE, DE, D	-0.5~ $V_{CC1}+0.5$	V
Receiver output current	$I_O$	-10~+10	mA
Bus side input voltage	A, B, Z, Y	-15~+15	V
Virtual junction temperature	$T_j$	150	°C
Ambient temperature	$T_{amb}$	-40~125	°C
Storage temperature	$T_{stg}$	-65~150	°C

The maximum limit parameters mean that exceeding these values may cause irreversible damage to the device. Under these conditions, it is not conducive to the normal operation of the device. The continuous operation of the device at the maximum allowable rating may affect the reliability of the device. The reference point for all voltages is ground.

**DRIVER DC ELECTRICAL CHARACTERISTICS**

PARAMETER	SYMBOL	CONDITION	MIN	TYP	MAX	UNIT
Differential driver output (no load)	$V_{OD1}$		3.3		5.5	V
Differential driver output	$V_{OD2}$	Fig 2, $R_L = 54 \Omega$	1.5		$V_{CC2}$	V
		Fig 2, $R_L = 100 \Omega$	1.5		$V_{CC2}$	V
Change in magnitude of output voltage (NOTE1)	$\Delta V_{OD}$	Fig 2, $R_L = 54 \Omega$			0.2	V
Common-mode output voltage	$V_{OC}$	Fig 2, $R_L = 54 \Omega$			3	V
Change in magnitude of common-mode output voltage (NOTE1)	$\Delta V_{OC}$	Fig 2, $R_L = 54 \Omega$			0.2	V
Input high voltage	$V_{IH}$	D	2.0			V
Input low voltage	$V_{IL}$	D			0.8	V
Logic input current	$I_{IN1}$	D	-15		20	$\mu A$
Output short-circuit current (shorted to high)	$I_{OSD1}$	Shorted to 0V~12V	35		250	mA
Output short-circuit current (shorted to low)	$I_{OSD2}$	Shorted to -7V~0V	-250		-35	mA

(Unless otherwise noted,  $V_{CC1} = 2.5V \sim 5.5V$ ,  $V_{CC2} = 4.5V \sim 5.5V$ ,  $T_{amb} = -40 \sim 125^\circ C$ ,  $T_{amb} = 25^\circ C$ .)

NOTE1:  $\Delta V_{OD}$  and  $\Delta V_{OC}$  are the changes in  $V_{OD}$  and  $V_{OC}$ , respectively, when the D input changes state.

**RECEIVER DC ELECTRICAL CHARACTERISTICS**

PARAMETER	SYMBOL	CONDITION	MIN	TYP	MAX	UNIT
Input current (A, B)	$I_{IN2}$	$V_{CC2} = 0$ or $3.3V$ $V_{IN} = 12V$			125	$\mu A$

PARAMETER	SYMBOL	CONDITION	MIN	TYP	MAX	UNIT
Input current (A, B)	$I_{IN2}$	$V_{CC2}=0$ or $3.3V$ $V_{IN} = -7V$	-200			$\mu A$
Positive input threshold voltage	$V_{IT+}$	$-7V \leq V_{CM} \leq 12V$			-10	mV
Reverse input threshold voltage	$V_{IT-}$	$-7V \leq V_{CM} \leq 12V$	-200			mV
Input hysteresis voltage	$V_{hys}$	$-7V \leq V_{CM} \leq 12V$	10	30		mV
Output High voltage	$V_{OH}$	$I_{OUT} = -4mA$ , $V_{ID} = -10mV$	$V_{CC2}-1.5$			V
Output Low voltage	$V_{OL}$	$I_{OUT} = +4mA$ , $V_{ID} = -200mV$			0.4	V
Three-state leakage current	$I_{OZR}$	$0.4V < V_O < 2.4V$			$\pm 15$	$\mu A$
Receiver input resistance	$R_{IN}$	$-7V \leq V_{CM} \leq 12V$	96			k $\Omega$
Receiver short-circuit output current	$I_{OSR}$	$0V \leq V_O \leq V_{CC}$			$\pm 150$	mA

(Unless otherwise noted,  $V_{CC1} = 2.5V \sim 5.5V$ ,  $V_{CC2} = 4.5V \sim 5.5V$ ,  $T_{amb} = -40 \sim 125^{\circ}C$ ,  $T_{amb} = 25^{\circ}C$ .)

## SUPPLY CURRENT

PARAMETER	SYMBOL	CONDITION	MIN	TYP	MAX	UNIT
Supply Current	$I_{CC1}$	$V_{CC1}=5V$ /RE= DE=VCC, no load		3.2	4.16	mA
	$I_{CC2}$	$V_{CC2}=5V$ /RE= DE=VCC, no load		2	2.6	mA

## ESD PROTECTION

PARAMETER	SYMBOL	CONDITION	MIN	TYP	MAX	UNIT
A, B, Y, Z		HBM		$\pm 15$		kV
Other pots		HBM		$\pm 6$		kV

**DRIVER SWITCHING CHARACTERISTICS**

PARAMETER	SYMBOL	CONDITION	MIN	TYP	MAX	UNIT	
Driver propagation delay, low-to-high level	$t_{DPLH}$	$R_L = 54 \Omega$ , $C_L = 100\text{pF}$ (Fig 3 & Fig 4)		15	35	ns	
Driver propagation delay, high-to-low level	$t_{DPHL}$			15	35	ns	
$ t_{DPLH} - t_{DPHL} $	$t_{SKEW1}$				7	10	ns
Rising time/Falling time	$t_{DR}, t_{DF}$				10	25	ns
Output enable time to high level	$t_{PZH}$	$R_L = 110\Omega$ , (Fig 5 & Fig 6)	20		90	ns	
Output enable time to low level	$t_{PZL}$		20		90	ns	
Output disable time from low level	$t_{PLZ}$	$R_L = 110\Omega$ , (Fig 5 & Fig 6)	20		80	ns	
Output disable time from high level	$t_{PHZ}$		20		80	ns	
In Shutdown mode, Enable to output high	$t_{DSH}$	$R_L = 110\Omega$ , (Fig 5 & Fig 6)	500		900	ns	
In Shutdown mode, Enable to output low	$t_{DSL}$	$R_L = 110\Omega$ , (Fig 5 & Fig 6)	500		900	ns	

**RECEIVER SWITCHING CHARACTERISTICS**

PARAMETER	SYMBOL	CONDITION	MIN	TYP	MAX	UNIT
Receiver propagation delay, low-to-high level	$t_{RPLH}$	$V_{ID} \geq 2.0\text{V}$ ; Rising and falling edge time $V_{ID} \leq 15\text{ns}$ (Fig 7 & Fig 8)	20	60	90	ns
Receiver propagation delay, high-to-low level	$t_{RPHL}$		20	60	90	ns
$ t_{RPLH} - t_{RPHL} $	$t_{SKEW2}$				7	10
Output enable time to low level	$t_{RPZL}$	$C_L = 15\text{pF}$ (Fig 7 & Fig 8)		20	50	ns

PARAMETER	SYMBOL	CONDITION	MIN	TYP	MAX	UNIT
Output enable time to high level	$t_{RPZH}$	$C_L=15pF$ ( <a href="#">Fig 7</a> & <a href="#">Fig 8</a> )		20	50	ns
Output disable time from low level	$t_{RPLZ}$	$C_L=15pF$ ( <a href="#">Fig 7</a> & <a href="#">Fig 8</a> )		20	45	ns
Output disable time from high level	$t_{RPHZ}$	$C_L=15pF$ ( <a href="#">Fig 7</a> & <a href="#">Fig 8</a> )		20	45	ns
In Shutdown mode, Enable to high level	$t_{RPSH}$	$C_L=15pF$ ( <a href="#">Fig 7</a> & <a href="#">Fig 8</a> )		200	1400	ns
In Shutdown mode, Enable to output low	$t_{RPSL}$	$C_L=15pF$ ( <a href="#">Fig 7</a> & <a href="#">Fig 8</a> )		200	1400	ns
Time to Shutdown	$t_{SHDN}$	NOTE2	80		300	ns

NOTE2: If the enable inputs are RE=high and DE=low for less than 50ns, the device is guaranteed not to enter shutdown. If the enable inputs are in this state for at least 300ns, the device is guaranteed to have entered shutdown.

**FUNCTION TABLE**
**Transmitter function truth table**

V <sub>CC1</sub>	V <sub>CC2</sub>	INPUT	ENABLE INPUT	OUTPUTS	
		(DI)	(DE)	Y	Z
PU	PU	H	H	H	L
PU	PU	L	H	L	H
PU	PU	X	L	Z	Z
PU	PU	X	OPEN	Z	Z
PU	PU	OPEN	H	H	L
PD	PU	X	X	Z	Z
PU	PD	X	X	Z	Z
PD	PD	X	X	Z	Z

(1) PU = Power up; PD =Power down; H =High level; L=Low level; X = Irrelevant; Z =High impedance.

**Receiver function truth table**

V <sub>CC1</sub>	V <sub>CC2</sub>	Differential Input V <sub>ID</sub> =(V <sub>A</sub> -V <sub>B</sub> )	Enable (/RE)	Output (R)
PU	PU	-0.01V ≤ V <sub>ID</sub>	L/OPEN	H
PU	PU	-0.2V < V <sub>ID</sub> < -0.01V	L/OPEN	?
PU	PU	V <sub>ID</sub> ≤ -0.2V	L/OPEN	L
PU	PU	X	H	Z
PU	PU	Open circuit	L	H
PU	PU	Short circuit	L	H
PU	PU	idle	L	H
PD	PU	X	X	Z
PU	PD	X	X	H
PD	PD	X	X	Z

(1) PU=Power up; PD=Power down; H=High level; L=Low level; X=Irrelevant; Z=High impedance; ? = Uncertain.

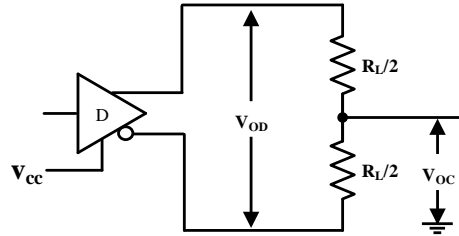
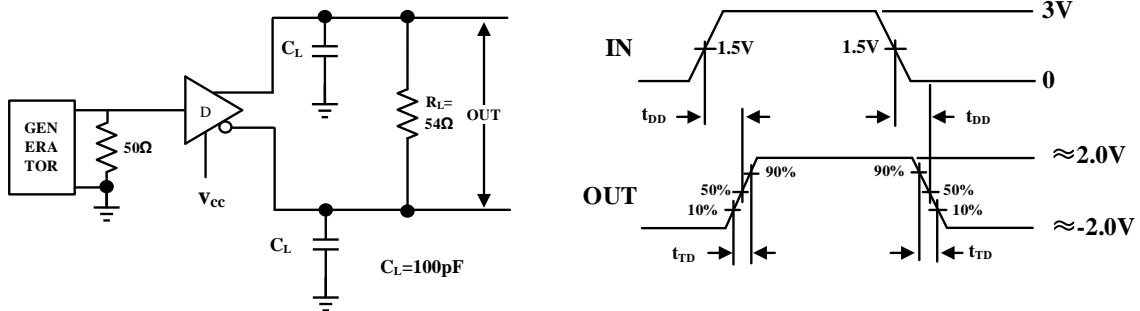

**TEST CIRCUIT**

**Fig 2 Driver DC test load**

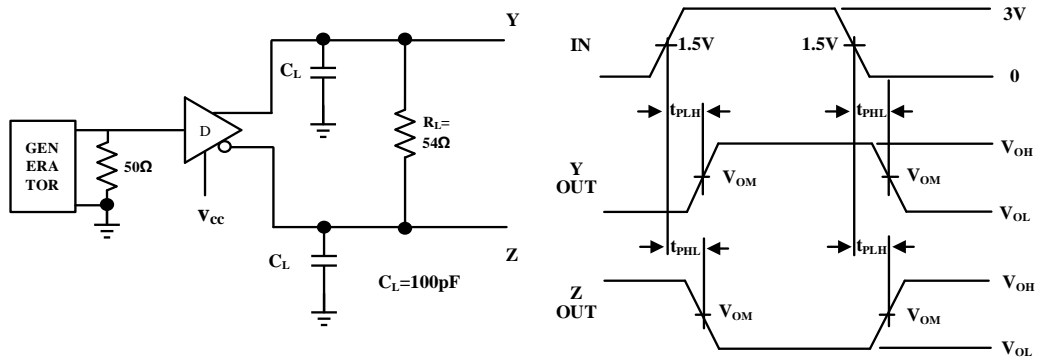
CL includes probe and stray capacitance (the same below).

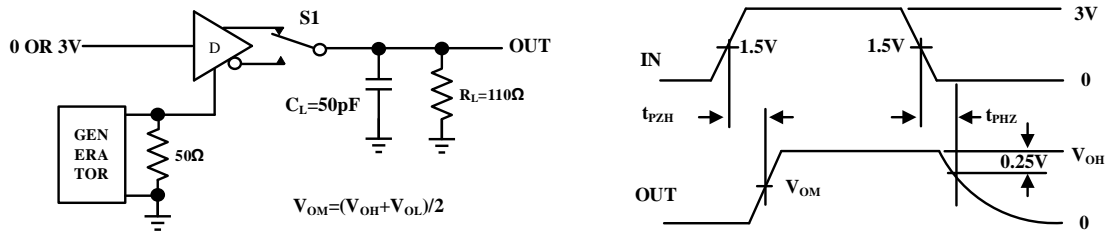
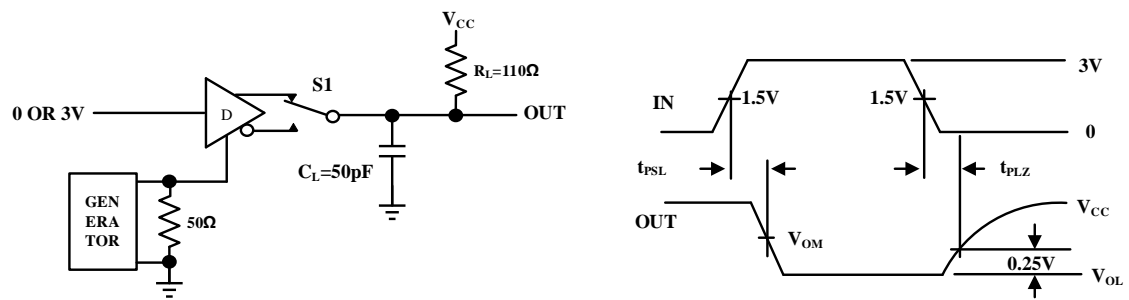
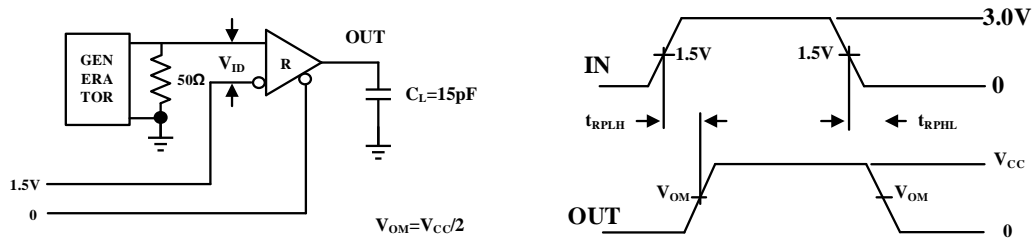
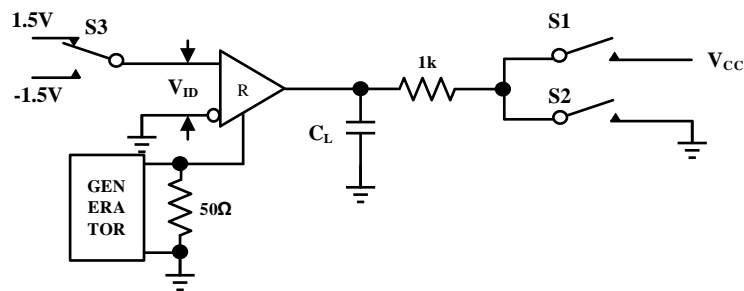
**Fig 3 Differential delay and transit time of driver**

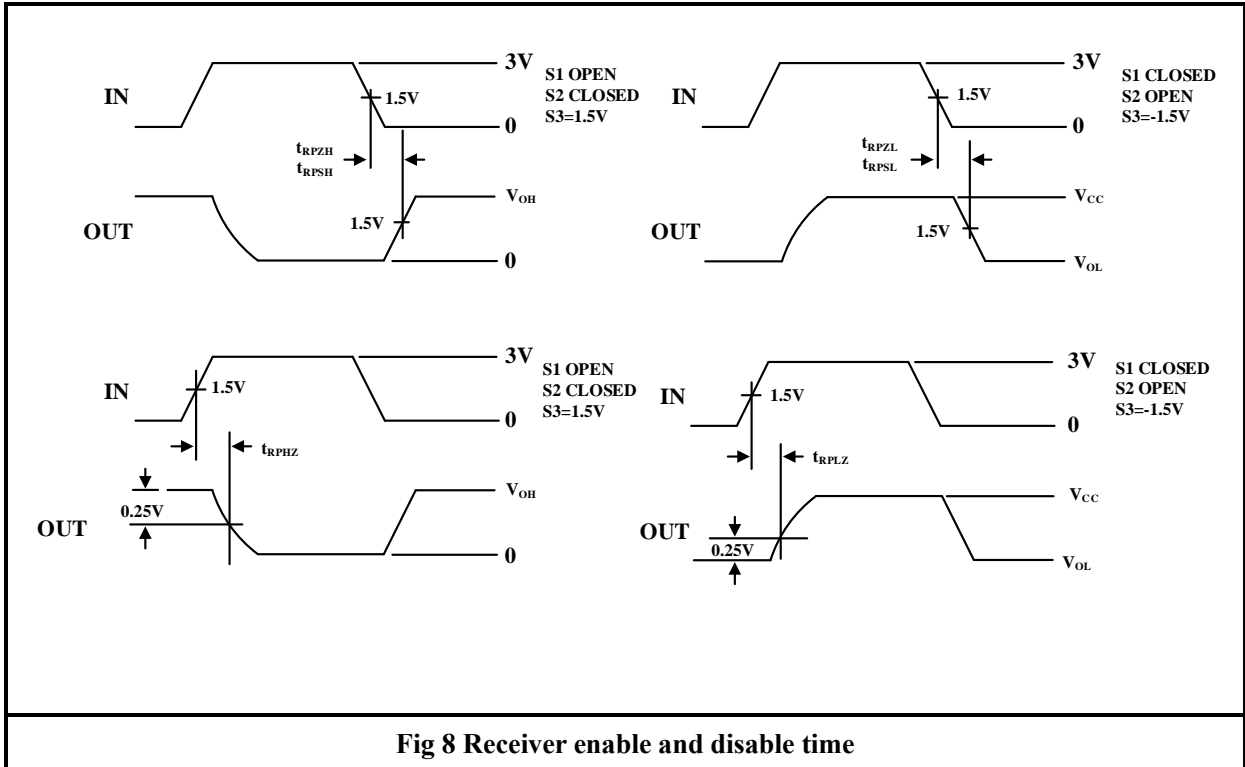
**Fig 4 Drive propagation delay**

**Fig 5 Drive enable and disable time**

**Fig 6 Drive enable and disable time**

**Fig 7 Receiver propagation delay test circuit**



**Fig 8 Receiver enable and disable time**

**ADDITIONAL DESCRIPTION****1 Sketch**

The SIT3491ISO is a capacitive isolated full duplex RS-422/RS-485 transceiver, and bus port ESD protection capacity of more than 15kV HBM, including a driver and receiver. It has the functions of fail-safe, over-voltage protection, and over-current protection. SIT3491ISO realizes error-free data transmission up to 16Mbps.

**2 Allowing up to 256 transceivers on the Bus**

The input impedance of the standard RS485 receiver is 12k $\Omega$  (1 unit load), and the standard driver can drive up to 32 unit loads. The receiver of SIT3491ISO transceiver has 1/8 unit load input impedance (96k $\Omega$ ), which allows up to 256 transceivers to be connected on the same communication bus in parallel. These devices can be combined arbitrarily or with other RS485 transceivers. Any combination of these devices and/or other RS485 transceivers with a total of 32 unit loads or less can be connected to the line.

**3 Driver output protection**

Over-current and overvoltage protection mechanisms are used to prevent excessive output current and power dissipation caused by faults or bus contention, providing fast short circuit protection over the entire common mode voltage range(refer to typical operating characteristics).

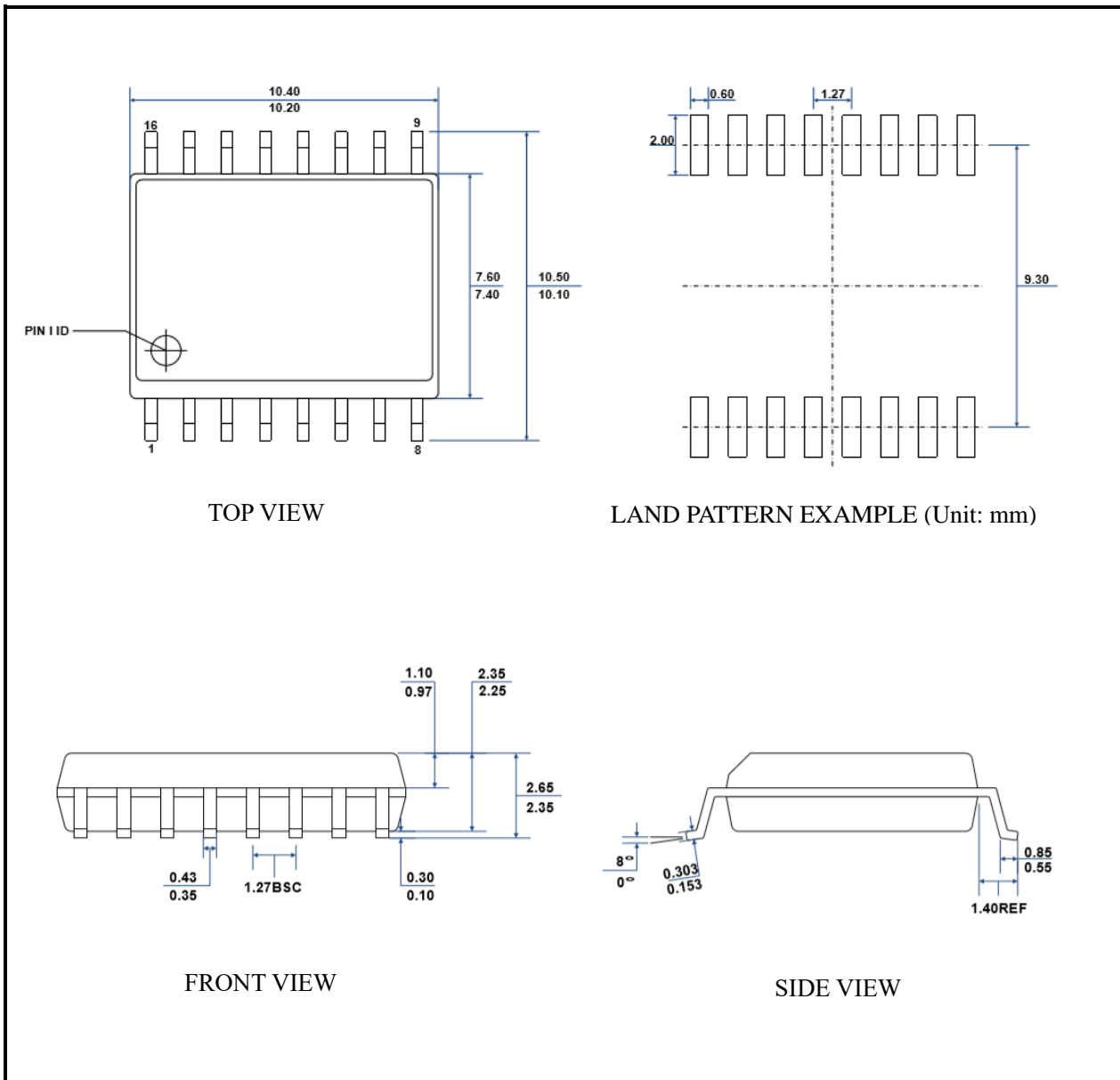
**SOIC16-WB WIDE BODY DIMENSIONS**

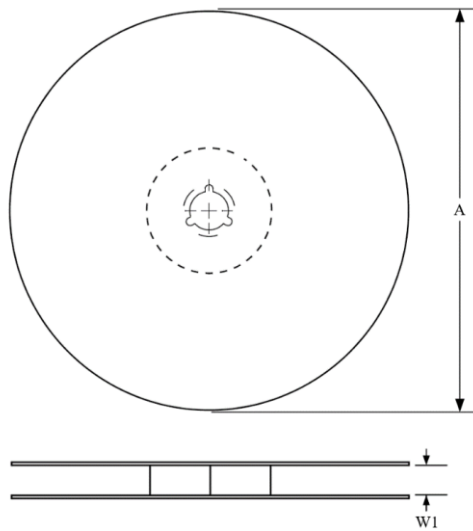
**TAPE AND REEL INFORMATION**

A0	Dimension designed to accommodate the component width
B0	Dimension designed to accommodate the component length
K0	Dimension designed to accommodate the component thickness
W	Overall width of the carrier tape
P1	Pitch between successive cavity centers

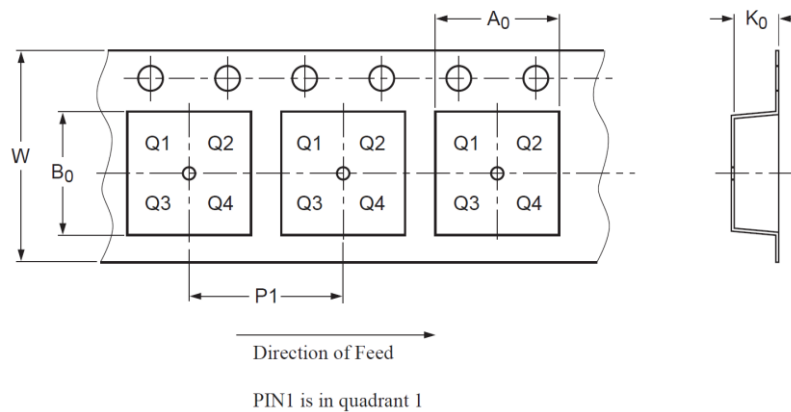

Package type	Reel diameter A (mm)	Tape width W1 (mm)	A0 (mm)	B0 (mm)	K0 (mm)	P1 (mm)	W (mm)
SOPW16	330±2.0	16.4 <sup>+2.0</sup> / <sub>+0.0</sub>	10.75±0.1	10.70±0.10	2.80±0.10	12.00±0.10	16.00±0.20

**ORDERING INFORMATION**

TYPE NUMBER	PACKAGE	PACKING
SIT3491ISO	SOPW16, body wide SOP16	Tape and reel

SOPW16 is packed with 1000 pieces/disc in braided packaging.

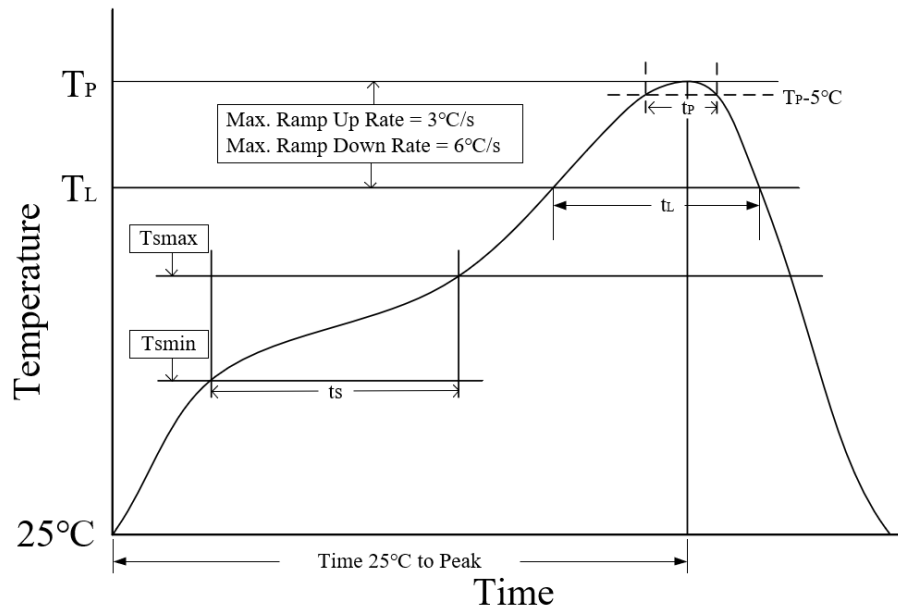
**REFLOW SOLDERING**

Parameter	Lead-free soldering conditions
Ave ramp up rate (T <sub>L</sub> to T <sub>P</sub> )	3 °C/second max
Preheat time t <sub>s</sub> (T <sub>smin</sub> =150 °C to T <sub>smax</sub> =200 °C)	60-120 seconds
Melting time t <sub>L</sub> (T <sub>L</sub> =217 °C)	60-150 seconds
Peak temp T <sub>P</sub>	260-265 °C
5°C below peak temperature t <sub>P</sub>	30 seconds
Ave cooling rate (T <sub>P</sub> to T <sub>L</sub> )	6 °C/second max
Normal temperature 25°C to peak temperature T <sub>P</sub> time	8 minutes max

**Important statement**

SIT reserves the right to change the above-mentioned information without prior notice.

**REVISION HISTORY**

Version number	Data sheet status	Revision Date
V1.0~V1.1	Product datasheet.	November 2020
V1.2	Updated $I_{IN1}$ parameters; Updated test condition of electrical parameters; Updated $I_{IN2}$ parameters; Updated $I_{OSR}$ parameters and test condition; Adjusted format.	October 2021
V1.3	Deleted overtemperature information; Added ambient temperature range $T_{amb}$ ; Updated $V_{OD2}$ parameters; Updated $V_{OD2}$ , $\Delta V_{OD}$ , $V_{OC}$ ; $\Delta V_{OC}$ test condition; Updated test circuit; Added tape and reel information; Updated ordering information; Added reflow soldering information; Added important statement; Added revision history.	July 2023