

**HIGH-PERFORMANCE PRODUCTS**
**Description**

The SK10E/100E111 is a low skew 1-to-9 differential driver designed with clock distribution in mind. It accepts one signal input which can be either differential or single-ended if the VBB output is used. The signal is fanned out to 9 identical differential outputs. An enable input is also provided. A HIGH disables the device by forcing all Q outputs LOW and all Q\* outputs HIGH.

The device is specifically designed, modeled, and produced with low skew as the key goal. Optimal design and layout serve to minimize gate-to-gate skew within-device, and characterization is used to determine process control limits that ensure consistent tpd distributions from lot to lot. The net result is a dependable, guaranteed low skew device.

To ensure that the tight skew specification is met, it is necessary that both sides of the differential output are terminated into  $50\Omega$ , even if only one side is being used. In most applications, all nine differential pairs will be used and therefore terminated. In the case where fewer than nine pairs are used, it is necessary to terminate at least the output pairs on the same package side (i.e. sharing the same VCC0) as the pair(s) being used on that side in order to maintain minimum skew. Failure to do this will result in small degradations of propagation delay (on the order of 10–20ps) of the output(s) being used which, while not being catastrophic to most designs, will mean a loss of skew margin.

**Features**

- Low Skew
- Guaranteed Skew Spec
- Differential Design
- VBB Output
- Enable Input
- Extended 100E VEE Range of  $-4.2$  to  $-5.5V$
- $75K\Omega$  Internal Input Pulldown Resistors
- Fully Compatible with MC10E111 and MC100E111
- Specified Over Industrial Temperature Range:  $-40^{\circ}C$  to  $85^{\circ}C$
- ESD Protection of  $>4000V$
- Available in 28-pin PLCC Package

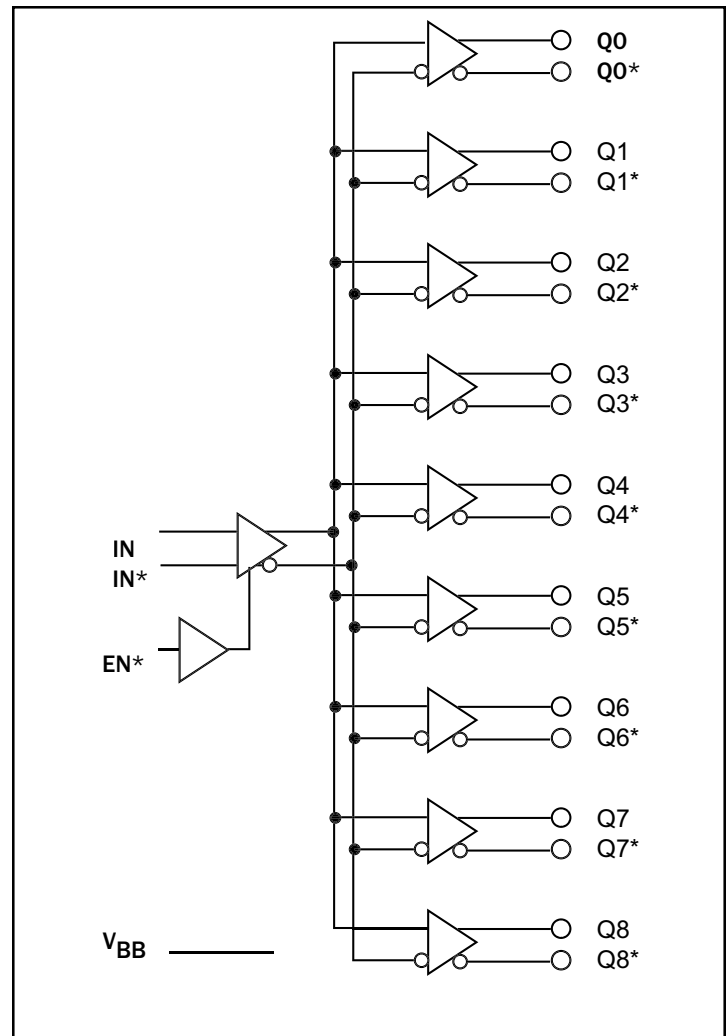
**Functional Block Diagram**

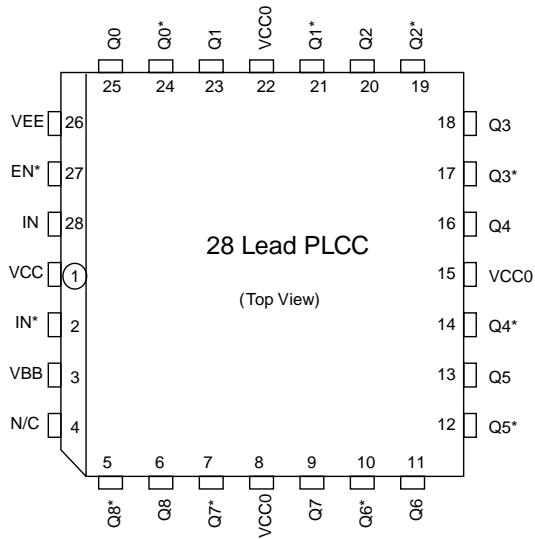
**Pinout**

**Pin Names**

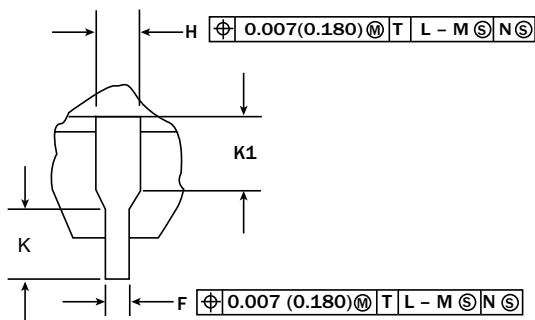
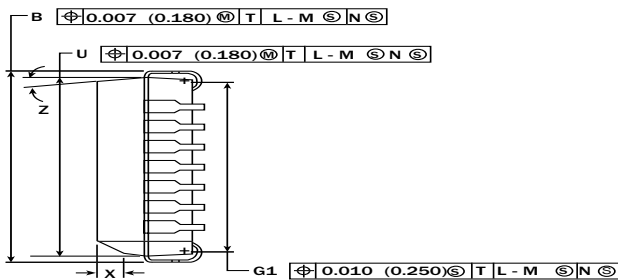
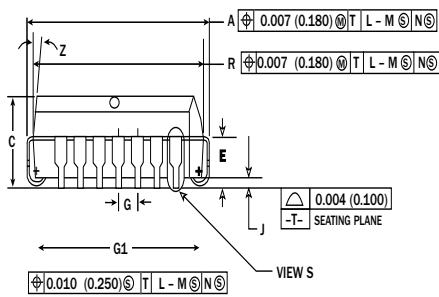
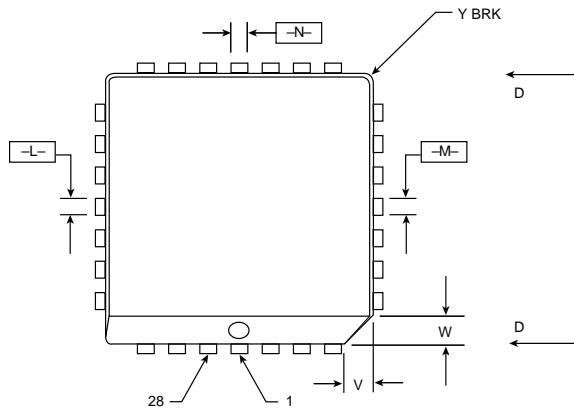
Pin	Function
IN, IN*	Differential Input Pair
EN*	Enable
Q0, Q0* - Q8, Q8*	Differential Outputs
VBB	VBB Output

**VIEW S**
**NOTES:**

1. Datums -L-, -M-, and -N- determined where top of lead shoulder exits plastic body at mold parting line.
2. DIM G1, true position to be measured at Datum -T-, Seating Plane.
3. DIM R and U do not include mold flash. Allowable mold flash is 0.010 (0.250) per side.
4. Dimensioning and tolerancing per ANSI Y14.5M, 1982.
5. Controlling Dimension: Inch.
6. The package top may be smaller than the package bottom by up to 0.012 (0.300). Dimensions R and U are determined at the outermost extremes of the plastic body exclusive of mold flash, tie bar burrs, gate burrs and interlead flash, but including any mismatch between the top and bottom of the plastic body.
7. Dimension H does not include Dambar protrusion or intrusion. The Dambar protrusion(s) shall not cause the H dimension to be greater than 0.037 (0.940). The Dambar intrusion(s) shall not cause the H dimension smaller than 0.025 (0.635).

DIM	INCHES		MILLIMETERS	
	MIN	MAX	MIN	MAX
A	0.485	0.495	12.32	12.57
B	0.485	0.495	12.32	12.57
C	0.165	0.180	4.20	4.57
E	0.090	0.110	2.29	2.79
F	0.013	0.019	0.33	0.48
G	0.050	BSC	1.27	BSC
H	0.026	0.032	0.66	0.81
J	0.020	-	0.51	-
K	0.025	-	0.64	-
R	0.450	0.456	11.43	11.58
U	0.450	0.456	11.43	11.58
V	0.042	0.048	1.07	1.21
W	0.042	0.048	1.07	1.21
X	0.042	0.056	1.07	1.42
Y	-	0.020	-	0.50
Z	2°	10°	2°	10°
G1	0.410	0.430	10.42	10.92
K1	0.040	-	1.02	-

**HIGH-PERFORMANCE PRODUCTS**
**DC Characteristics**
**SK10/100E111 DC Electrical Characteristics** (Notes 1, 2)

 (V<sub>CC</sub> – V<sub>EE</sub> = 4.2V to 5.5V; V<sub>OUT</sub> Loaded 50Ω to V<sub>CC</sub> – 2.0V)

Symbol	Characteristic	TA = –40°C		TA = 0°C		TA = +25°C		TA = +85°C		Unit
		Min	Max	Min	Max	Min	Max	Min	Max	
V <sub>B</sub> B	Output Reference Voltage <sup>13</sup>									
	10EL	-1.43	-1.30	-1.38	-1.27	-1.35	-1.25	-1.31	-1.19	V
	100EL	-1.38	-1.26	-1.38	-1.26	-1.38	-1.26	-1.38	-1.26	V
I <sub>IN</sub>	Input Current (Diff) (SE)	-150	150	-150	150	-150	150	-150	150	μA μA
I <sub>EE</sub>	Power Supply Current		64		64		64		64	mA

**AC Characteristics**
**SK10/100E111 AC Electrical Characteristics**

 (V<sub>CC</sub> – V<sub>EE</sub> = 4.2V to 5.5V; V<sub>OUT</sub> Loaded 50Ω to V<sub>CC</sub> – 2.0V)

Symbol	Characteristic	TA = –40°C			TA = 0°C			TA = +25°C			TA = +85°C			Unit
		Min	Typ	Max	Min	Typ	Max	Min	Typ	Max	Min	Typ	Max	
t <sub>PLH</sub> t <sub>PHL</sub>	Propagation Delay to Output IN (Diff) <sup>5</sup> IN (SE) <sup>6</sup> Enable <sup>7</sup> Disable	475 280 400 400		630 780 900 900	490 330 450 450		655 730 850 850	500 330 450 450		660 730 850 850	520 330 450 450		655 730 850 850	ps ps ps ps
t <sub>s</sub>	Setup Time <sup>9</sup> EN to IN	250	0		200	0		200	0		200	0		ps
t <sub>H</sub>	Hold Time <sup>10</sup> IN to EN	50	-200		0	-200		0	-200		0	-200		ps
t <sub>R</sub>	Release Time <sup>11</sup> EN* to IN	350	100		300	100		300	100		300	100		ps
t <sub>skew</sub>	Within-Device Skew <sup>8</sup>		25	75		25	50		25	50		25	50	ps
V <sub>PP(AC)</sub>	Minimum Input Swing <sup>12</sup>	250		1000	250		1000	250		1000	250		1000	mV
V <sub>CMR</sub>	Common Mode Range <sup>4</sup>	V <sub>EE</sub> + 1.6		V <sub>CC</sub> – 0.4	V <sub>EE</sub> + 1.6		V <sub>CC</sub> – 0.4	V <sub>EE</sub> + 1.6		V <sub>CC</sub> – 0.4	V <sub>EE</sub> + 1.6		V <sub>CC</sub> – 0.4	V
t <sub>r</sub> , t <sub>f</sub>	Rise/Fall Time 20% to 80%	215	450	545	225	375	570	230	375	545	240	375	475	ps

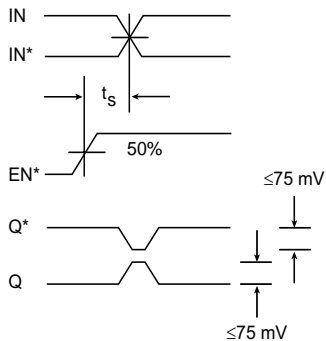
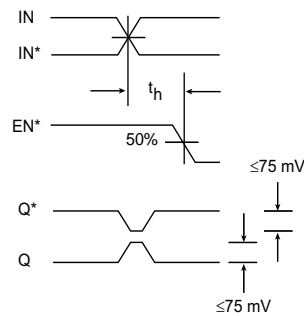
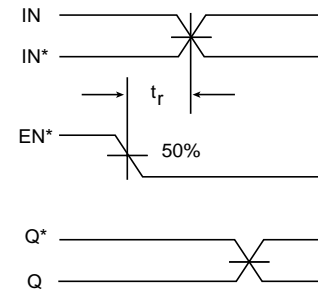
**HIGH-PERFORMANCE PRODUCTS**
**AC Characteristics (continued)**

**Figure 1. Setup Time**

**Figure 2. Hold Time**

**Figure 3. Release Time**
**Notes:**

1. 10E circuits are designed to meet the DC specifications shown in the table after thermal equilibrium has been established. The circuit is in a test socket or mounted on a printed circuit board and transverse airflow greater than 500 lfm is maintained.
2. 100E circuits are designed to meet the DC specifications shown in the table where transverse airflow greater than 500 lfm is maintained.
3. Differential input voltage required to obtain a full ECL swing on the outputs.
4.  $V_{CMR}$  range is referenced to the most positive side of the differential input signal. Normal operation is obtained if the high level falls within the specified range and the peak-to-peak voltage lies between  $V_{PP(min)}$  and 1V. The lower end of  $V_{CMR}$  range varies 1:1 with VEE and is equal to  $VEE+1.6V$ .
5. The differential propagation delay is defined as the delay from the crossing points of the differential input signals to the crossing point of the differential output signals.
6. The single-ended propagation delay is defined as the delay from the 50% point of the input signal to the 50% point of the output signal.
7. Enable is defined as the propagation delay from the 50% point of a **negative** transition on EN\* to the 50% point of a **positive** transition on Q (or a negative transition on Q). Disable is defined as the propagation delay from the 50% point of a **positive** transition on EN\* to the 50% point of a **negative** transition on Q (or a positive transition on Q).
8. The within-device skew is defined as the worst case difference between any two similar delay paths within a single device.
9. The setup time is the minimum time that EN must be asserted prior to the next transition of IN/IN to prevent an output response greater than  $\pm 75$  mV to that IN/IN transition (see Figure 1).
10. The hold time is the minimum time that EN must remain asserted after a negative going IN or a positive going IN\* to prevent an output response greater than  $\pm 75$  mV to the IN/IN transition (see Figure 2).
11. The release time is the minimum time that EN must be deasserted prior to the next IN/IN\* transition to ensure an output response that meets the specified IN to Q propagation delay and output transition times (see Figure 3).
12.  $V_{pp(min)}$  is defined as the minimum input differential voltage which will cause no increase in the propagation delay. The  $V_{pp(min)}$  is AC limited for the E111 as a differential input as low as 250 mV will still produce full ECL levels at the output.
13. Voltages referenced to  $V_{CC} = 0V$ .
14. For standard ECL DC specifications, refer to the ECL Logic Family Standard DC Specifications Data Sheet.
15. For part ordering descriptions, see HPP Part Ordering Information Data Sheet.

**HIGH-PERFORMANCE PRODUCTS****Ordering Information**

<b>Ordering Code</b>	<b>Package ID</b>	<b>Temperature Range</b>
SK10E111PJ	28-PLCC	Industrial
SK10E111PJT	28-PLCC	Industrial
SK100E111PJ	28-PLCC	Industrial
SK100E111PJT	28-PLCC	Industrial

**Contact Information**

Division Headquarters  
10021 Willow Creek Road  
San Diego, CA 92131  
Phone: (858) 695-1808  
FAX: (858) 695-2633

**Semtech Corporation**  
**High-Performance Products Division**

Marketing Group  
1111 Comstock Street  
Santa Clara, CA 95054  
Phone: (408) 566-8776  
FAX: (408) 727-8994