

FEATURES

- * Ideal for surface mounted applications
- * Low leakage current
- * Metallurgically bonded construction
- * High reliability
- * RoHS product for packing code suffix "G"
- Halogen free product for packing code suffix "H"

MECHANICAL DATA

- * Case: Molded plastic
- * Epoxy: UL 94V-O rate flame retardant
- * Mounting position: Any
- * Weight: 0.104 gram

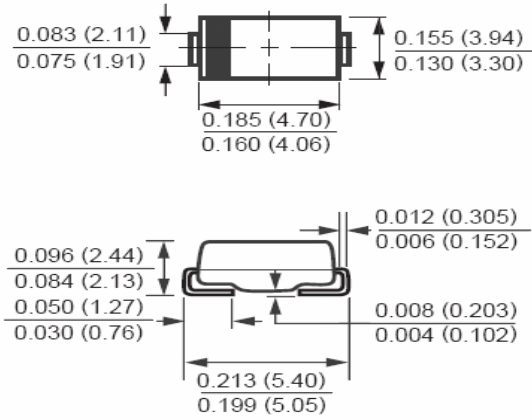

Dimensions in inches and (millimeters)

MAXIMUM RATINGS AND ELECTRICAL CHARACTERISTICS

Ratings at 25°C ambient temperature unless otherwise specified.
 Single phase half wave, 60Hz, resistive of inductive load.
 For capacitive load, derate current by 20%

RATINGS	SYMBOL	SK12B	SK13B	SK14B	SK15B	SK16B	SK18B	SK110B	SK115B	SK120B	UNIT
Marking Code		SK12B	SK13B	SK14B	SK15B	SK16B	SK18B	SK110B	SK115B	SK120B	
Maximum Recurrent Peak Reverse Voltage	V _{RRM}	20	30	40	50	60	80	100	150	200	Volts
Maximum RMS Voltage	V _{RMS}	14	21	28	35	42	56	70	105	140	Volts
Maximum DC Blocking Voltage	V _{DC}	20	30	40	50	60	80	100	150	200	Volts
Maximum Average Forward Rectified Current	I _O	1.0									Amps
Peak Forward Surge Current 8.3 ms single half sine-wave superimposed on rated load (JEDEC method)	I _{FSM}	30.0									Amps
Typical Thermal Resistance	R _{θJA}	50									°C/W
	R _{θJC}	20									°C/W
Typical Junction Capacitance (Note 1)	C _J	70			60		50		35		pF
Operating Temperature Range	T _J	-55 to +125									°C
Storage Temperature Range	T _{STG}	-55 to +150									°C

CHARACTERISTICS	SYMBOL	SK12B	SK13B	SK14B	SK15B	SK16B	SK18B	SK110B	SK115B	SK120B	UNIT	
Maximum Forward Voltage at 1.0A DC	@TA=25°C V _F	0.50			0.70		0.85		0.87		0.90	Volts
Maximum Average Reverse Current at	@TA=25°C	I _R	0.5				0.2				mAmps	
Rated DC Blocking Voltage	@TA=100°C		10.0				5.0					

Note : 1.Measured at 1 MHz and applied reverse voltage of 4.0 volts.

FIG. 1-TYPICAL FORWARD CURRENT DERATING CURVE

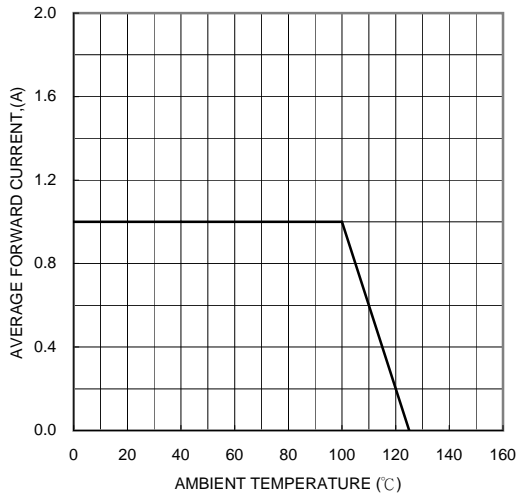

FIG. 2-TYPICAL FORWARD CHARACTERISTICS

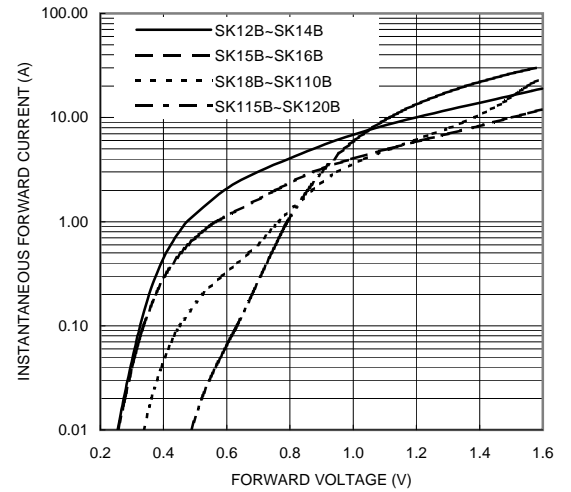

FIG. 3-MAXIMUM NON-REPETITIVE FORWARD SURGE CURRENT

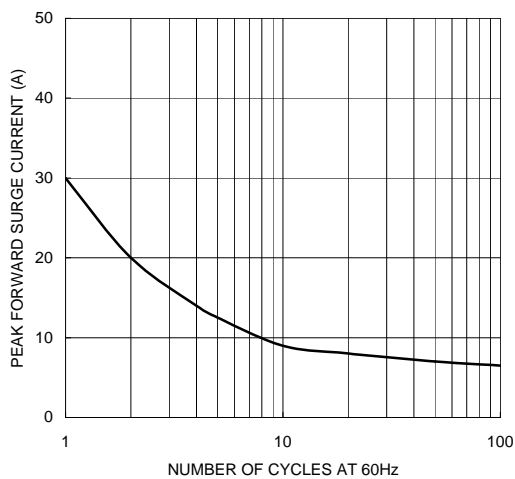

FIG. 4-TYPICAL REVERSE CHARACTERISTICS

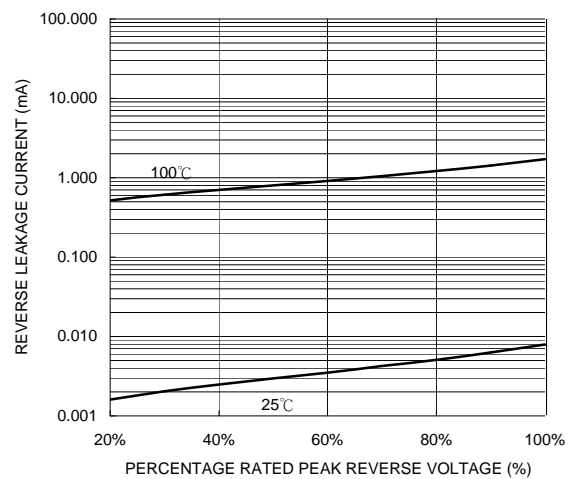

FIG. 5-TYPICAL JUNCTION CAPACITANCE

