

# SK 300MB075

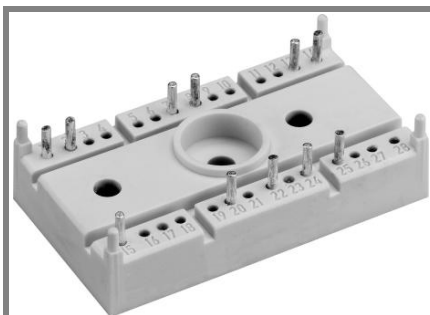

SEMITOP® 3

## Mosfet Module

### SK 300MB075

Preliminary Data

### Features

- Compact design
- One screw mounting
- Heat transfer and isolation through direct copper bonded aluminium oxide ceramic (DCB)
- Trench technology
- Short internal connections and low inductance case

### Typical Applications

- Low switched mode power supplies
- DC servo drives
- UPS

1) Maximum PCB temperature, at pins/PCB contact, = 85°C

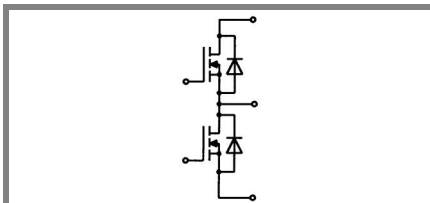

MB

Absolute Maximum Ratings		$T_s = 25\text{ °C}$ , unless otherwise specified	
Symbol	Conditions	Values	Units
<b>IGBT</b>			
$V_{DSS}$		75	V
$V_{GSS}$		$\pm 20$	V
$I_D$	$T_s = 25\text{ (80) °C}$ ; <sup>1)</sup>	290 (210)	A
$I_{DM}$	$t_p < 1\text{ ms}$ ; $T_s = 25\text{ (80) °C}$ ; <sup>1)</sup>	580 (420)	A
$T_j$		-40...+150	°C
<b>Inverse diode</b>			
$I_F = -I_D$	$T_s = 25\text{ (80) °C}$ ;	290 (210)	A
$I_{FM} = -I_{DM}$	$t_p < 1\text{ ms}$ ; $T_s = 25\text{ (80) °C}$ ;	580 (210)	A
$T_j$		-40...+150	°C
<b>Freewheeling CAL diode</b>			
$I_F = -I_D$	$T_s = \text{°C}$		A
$T_j$			°C
$T_{stg}$		- 40 ... + 125	°C
$T_{sol}$	Terminals, 10 s	260	°C
$V_{isol}$	a. c. 50 Hz; r.m.s.; 1 min (1s)	2500 / 3000	V

Characteristics		$T_s = 25\text{ °C}$ , unless otherwise specified			
Symbol	Conditions	min.	typ.	max.	Units
<b>MOSFET</b>					
$V_{(BR)DSS}$	$V_{GS} = 0\text{ V}$ ; $I_D = 5,6\text{ mA}$	$\geq V_{DSS}$			V
$V_{GS(th)}$	$V_{GS} = V_{DS}$ ; $I_D = 5,6\text{ mA}$	2,5	3,3		V
$I_{DSS}$	$V_{GS} = 0\text{ V}$ ; $V_{DS} = V_{DSS}$ ; $T_j = 25\text{ (125) °C}$			100 (500)	$\mu\text{A}$
$I_{GSS}$	$V_{GS} = 20\text{ V}$ ; $V_{DS} = 0\text{ V}$			100	nA
$R_{DS(on)}$	$I_D = 200\text{ A}$ ; $V_{GS} = 10\text{ V}$ ; $T_j = 25\text{ °C}$			1,6	m $\Omega$
$R_{DS(on)}$	$I_D = 200\text{ A}$ ; $V_{GS} = 10\text{ V}$ ; $T_j = 125\text{ °C}$	2,3		3	m $\Omega$
$C_{CHC}$	per MOSFET				pF
$C_{iss}$	under following conditions:		18,9		nF
$C_{oss}$	$V_{GS} = 0\text{ V}$ ; $V_{DS} = 25\text{ V}$ ; $f = 1\text{ MHz}$		3,6		nF
$C_{rss}$			1,1		nF
$L_{DS}$			2,2		nH
$t_{d(on)}$	under following conditions:		350		ns
$t_r$	$V_{DD} = 40\text{ V}$ ; $V_{GS} = 10\text{ V}$ ; $I_D = 300\text{ A}$		620		ns
$t_{d(off)}$	$R_G = 25\text{ }\Omega$		1250		ns
$t_f$			400		ns
$R_{th(j-s)}$	per MOSFET (per module)			0,45	K/W
<b>Inverse diode</b>					
$V_{SD}$	$I_F = 300\text{ A}$ ; $V_{GS} = 0\text{ V}$ ; $T_j = 25\text{ °C}$		0,8		V
$I_{RRM}$	under following conditions:				A
$Q_{rr}$	$I_F = \text{A}$ ; $T_{vj} = \text{°C}$ ; $R_G = \Omega$				$\mu\text{C}$
$t_{rr}$	$V_R = \text{A}$ ; $di/dt = \text{A}/\mu\text{s}$				ns
<b>Free-wheeling diode</b>					
$V_F$	$I_F = \text{A}$ ; $V_{GS} = \text{V}$				V
$I_{RRM}$	under following conditions:				A
$Q_{rr}$	$I_F = \text{A}$ ; $T_{vj} = \text{°C}$				$\mu\text{C}$
$t_{rr}$	$V_r = \text{A}$ ; $di/dt = \text{A}/\mu\text{s}$				ns
<b>Mechanical data</b>					
M1	mounting torque			2,5	Nm
w			30		g
Case	SEMITOP® 3		T 24		

# SK 300MB075

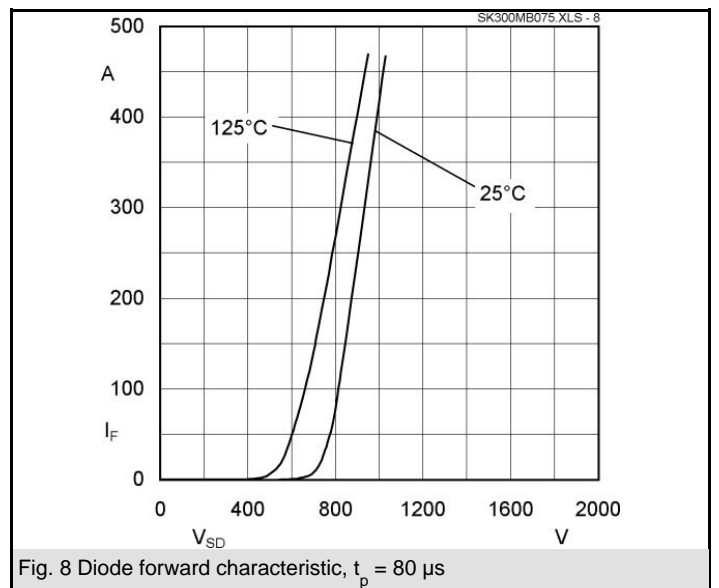
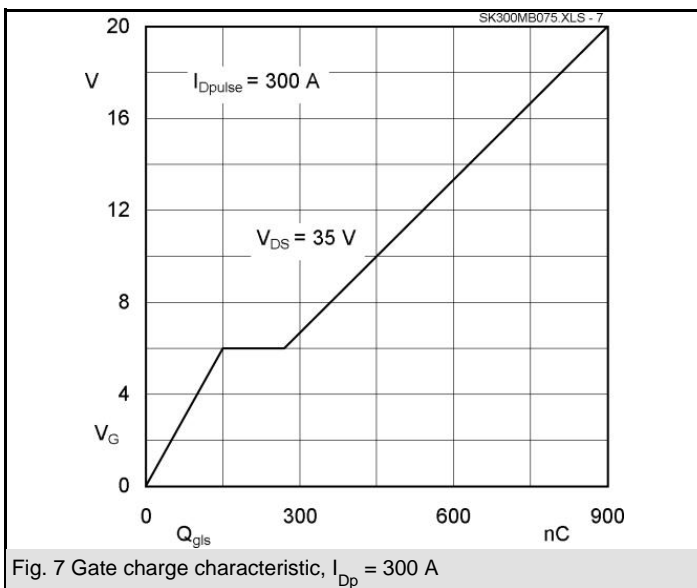
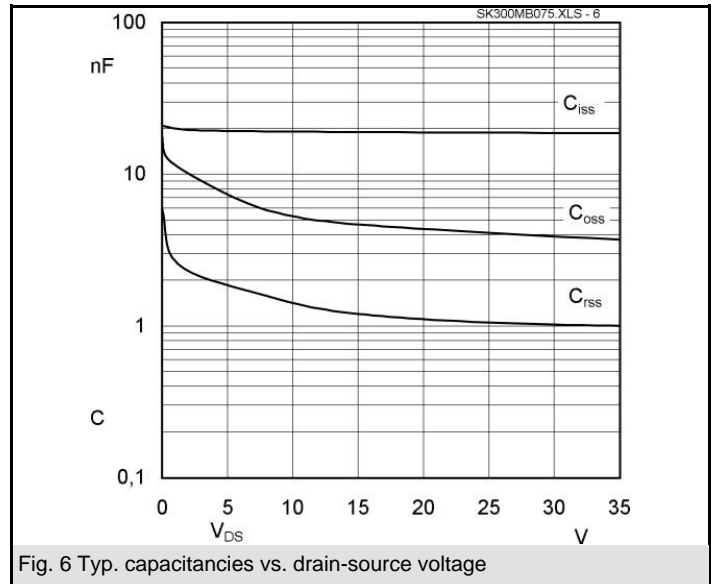
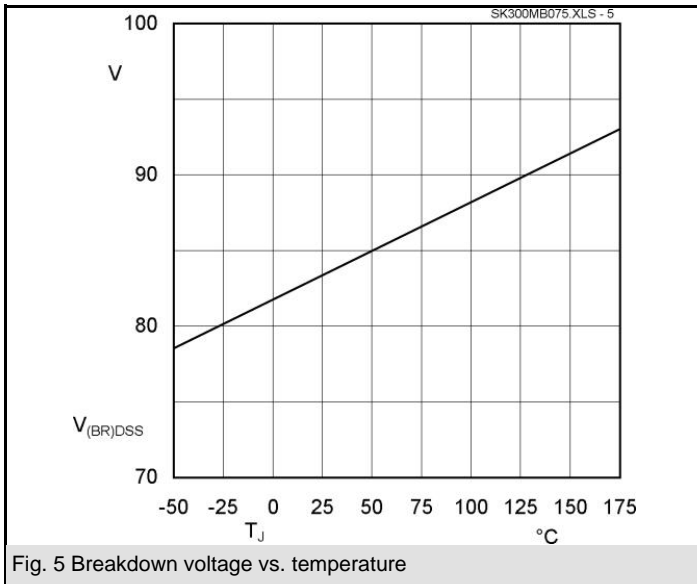
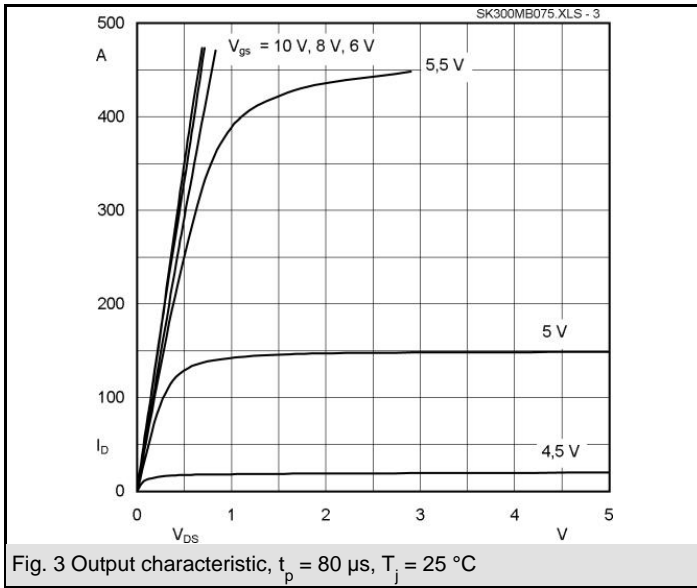

www.DataSheet4U.com

www.DataSheet4U.com

# SK 300MB075

Dimensions in mm

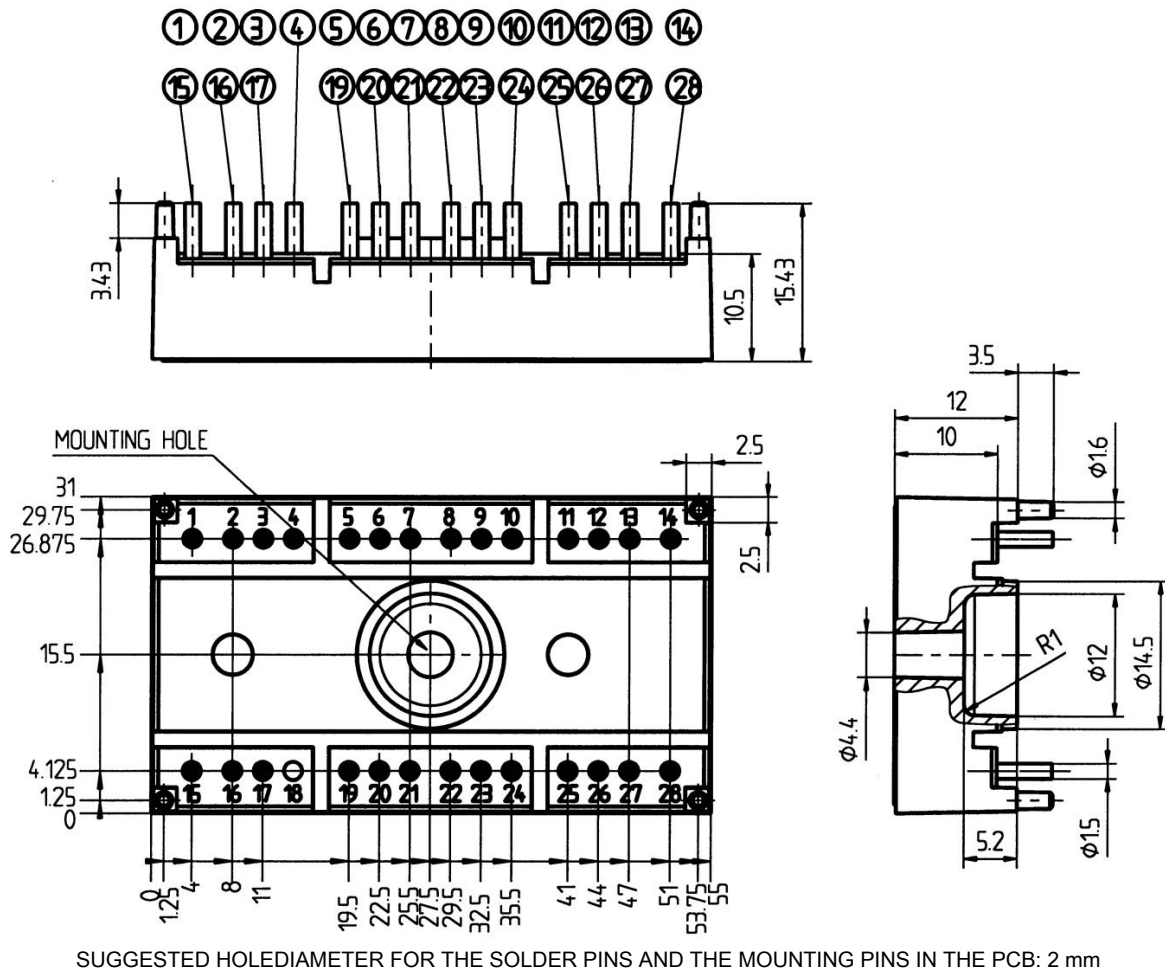

Case T24

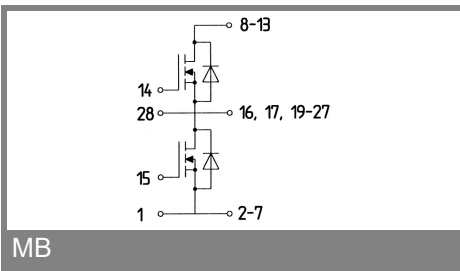

This is an electrostatic discharge sensitive device (ESDS), international standard IEC 60747-1, Chapter IX.

This technical information specifies semiconductor devices but promises no characteristics. No warranty or guarantee expressed or implied is made regarding delivery, performance or suitability.